

ROBINAIR

Instruction Manual

(original instructions)

Manual de instrucciones

Guide d'utilisation

Model 34998



Recover, Recycle, Recharge Machine
for R-134a A/C Systems

Description: Recover, recycle, and recharge machine for use with R-134a equipped air conditioning systems.

PRODUCT INFORMATION

Record the serial number and year of manufacture of this unit for future reference. Refer to the product identification label on the unit for information.

Serial Number: _____ Year of Manufacture: _____

DISCLAIMER: Information, illustrations, and specifications contained in this manual are based on the latest information available at the time of publication. The right is reserved to make changes at any time without obligation to notify any person or organization of such revisions or changes. Further, ROBINAIR shall not be liable for errors contained herein or for incidental or consequential damages (including lost profits) in connection with the furnishing, performance, or use of this material. If necessary, obtain additional health and safety information from the appropriate government agencies, and the vehicle, refrigerant, and lubricant manufacturers.

Table of Contents

Safety Precautions	2	Initial Setup12
Explanation of Safety Signal Words	2	Unpack the Accessory Kit	12
Explanation of Safety Decals.	2	Power Up the Machine	12
Protective Devices	4	Select Language	13
Refrigerant Tank Test	4	Connect to a Wireless (Wi-Fi) Network	13
J2843 Requirement Regarding Lubricant	4	Setup a Wireless Printer	13
Caution Statement — Modifications	4	Edit Print Header	13
Introduction	5	Set Date and Time	14
Technical Specifications	5	License Agreement	14
Features	6	Service Vacuum	14
Icon Legend	8	Adjust Background Fill Target	14
Main Menu Functions	9	Tank Fill	15
Info and Status	9	Unit Registration	16
Settings	9	Operating Instructions17
Service Data	9	Enter Service Data	17
Rename Oil Bottle	9	Recover Refrigerant from a Vehicle.	18
Setup Menu Functions.	10	Evacuate the Vehicle A/C System	19
Calibration Check	10	Flushing the Hoses	20
Filter Maintenance	10	Recharge the Vehicle A/C System.	21
Flush Hoses	10	Automatic Function	22
Production Menu	10	System Flush	23
Pump Maintenance	10	Maintenance Schedule	25
Refrigerant Management	10	Maintenance26
System Flush	10	Adjust Background Fill Target	26
Service Menu	10	Tank Fill	26
Tank Fill	10	Filter Maintenance	27
Hose Equalize	10	Check Remaining Filter Capacity	27
Set Oil Inject Viscosity	10	Replace the Filter	28
Internal Tank Status	10	Calibration Check	29
Buzzer Settings	10	Change Vacuum Pump Oil	30
Adjust Zero Offset	10	Leak Check	31
Leak Check	10	Print a Service Record.	32
Enable Identifier	11	Update Software	32
Replace Service Hoses	11	Replacement Parts	33
System Information	11	Glossary	33
Boost Refrigerant	11		.34
Temperature Sensor Snapshot	11	Troubleshooting Messages37
Default Vacuum Time	11	Storage and Transportation of Equipment37
Adjust Background Fill Target	11	Transportation of Equipment	37
Operating Requirements and Conditions	11	Disposal of Equipment38
FCC ID	11	Disposal of Recycled Materials	38
Mobile Device RF Exposure Statement.	11	Disposal of the Machine	38
FCC Part 15 Statement	11	Disposal of Batteries	38

Safety Precautions

Explanation of Safety Signal Words Used in this Manual

The safety signal word designates the degree, or level, of hazard seriousness.

 **DANGER:** Indicates an imminently hazardous situation which, if not avoided, will result in death or serious injury.

 **WARNING:** Indicates a potentially hazardous situation which, if not avoided, could result in death or serious injury.

 **CAUTION:** Indicates a potentially hazardous situation which, if not avoided, could result in minor or moderate injury.

CAUTION: Used without the safety alert symbol indicates a potentially hazardous situation which, if not avoided, could result in property damage.

These safety messages cover situations Robinair is aware of. Robinair cannot know, evaluate, or advise as to all possible hazards. The user must verify that conditions and procedures do not jeopardize personal safety.

Explanation of Safety Decals Used on the Machine

	Carefully read the instructions.
	Do not use in open air in case of rain or high humidity.
	Wear gloves.
	Wear protection goggles.
	Alternating voltage.
	Grounding protection.
	Electrical shock hazard.

Safety Precautions



WARNING: To prevent personal injury,



ALLOW ONLY QUALIFIED PERSONNEL TO OPERATE THE MACHINE . Before operating the machine, read and follow the instructions and warnings in this manual. The operator must be familiar with air conditioning and refrigeration systems, refrigerants, and the dangers of pressurized components. If the operator cannot read this manual, operating instructions and safety precautions must be read and discussed in the operator's native language.



USE THE MACHINE AS OUTLINED IN THIS MANUAL . Using the machine in a manner for which it was not designed will compromise the machine and nullify the protections provided.



PRESSURIZED TANK CONTAINS LIQUID REFRIGERANT . Do not overfill the internal storage vessel (ISV). Overfilling can cause explosion resulting in personal injury or death. Do not recover refrigerants into nonrefillable containers; use only type-approved refillable containers that have pressure relief valves.



HOSES CAN CONTAIN LIQUID REFRIGERANT UNDER PRESSURE . Contact with refrigerant can cause personal injury, including blindness and frozen skin. Wear protective equipment, including goggles and gloves. Disconnect hoses using extreme caution. Ensure the phase is complete before disconnecting the machine to prevent the release of refrigeration to the atmosphere.



AVOID BREATHING A/C REFRIGERANT AND LUBRICANT VAPOR OR MIST . Exposure can irritate eyes, nose, and throat. To remove refrigerant from the A/C system, use only equipment certified for the type of refrigerant being removed. Use the unit in locations with mechanical ventilation that provides at least four air changes per hour. If accidental system discharge occurs, ventilate the work area before resuming service.

DO NOT DISPERSE REFRIGERANT INTO THE ENVIRONMENT . Prevent the possible presence of refrigerant in the working environment.



TO REDUCE THE RISK OF FIRE, do not use the machine in the vicinity of spilled or open containers of gasoline or other flammable substances.

TO REDUCE THE RISK OF FIRE, do not use an extension cord . An extension cord can overheat and cause fire. If an extension cord must be used, use the shortest possible cord with a minimum size of 14 AWG.

TO REDUCE THE RISK OF FIRE, do not use the machine in the vicinity of flames and hot surfaces . Refrigerant can decompose at high temperatures and free toxic substances to the environment that can be noxious to the user.

TO REDUCE THE RISK OF FIRE, do not use the machine in environments containing explosive gases or vapors.

TO REDUCE THE RISK OF FIRE, do not use this machine in ATEX classified zones or areas. Protect the machine from conditions that can cause electrical failure or other hazards relating to ambient interaction.



CAUTION—DO NOT PRESSURE TEST OR LEAK TEST EQUIPMENT AND/OR VEHICLE AIR CONDITIONING SYSTEMS WITH COMPRESSED AIR . Mixtures of air and R-134a refrigerant can be combustible at elevated pressures. These mixtures are potentially dangerous and can result in fire or explosion causing personal injury and/or property damage.



HIGH VOLTAGE ELECTRICITY INSIDE THE MACHINE HAS A RISK OF ELECTRICAL SHOCK . Exposure can cause personal injury. Disconnect power before servicing the machine.

NEVER LEAVE THE MACHINE LIVE IF AN IMMEDIATE USE IS NOT SCHEDULED . Disconnect the electrical supply before a long period of inactivity or before internal maintenance is performed.

DO NOT MODIFY THE PRESSURE RELIEF VALVE OR CHANGE THE CONTROL SYSTEM SETTINGS .

Using the machine in a manner for which it was not designed will compromise the machine and nullify the protections provided.

Additional health and safety information can be obtained from refrigerant and lubricant manufacturers .

Safety Precautions

CAUTION : To prevent equipment damage,



TO PREVENT CROSS-CONTAMINATION, USE THIS MACHINE WITH R-134A REFRIGERANT ONLY .

The machine is equipped with special connectors to recover, recycle, and recharge only R-134a refrigerant. Do not attempt to adapt the machine for another refrigerant. Do not mix refrigerant types through a system or in the same container; mixing of refrigerants will cause severe damage to the machine and the vehicle air conditioning system.

DO NOT USE THIS MACHINE IN DIRECT SUNLIGHT . Position the machine far from heat sources, such as direct sunlight, which can cause excessive temperatures. The use of this machine under normal environmental conditions (10°C to 50°C) keeps pressures under reasonable limits.



DO NOT USE THIS MACHINE OUTDOORS DURING RAIN OR HIGH HUMIDITY . Protect the machine from conditions that can cause electrical failure or other hazards relating to ambient interaction.

DO NOT USE THIS MACHINE IN AREAS WHERE THERE IS A RISK OF EXPLOSION .

SET UP THE MACHINE ON AN EVEN SURFACE AND UNDER SUFFICIENT LIGHTING . LOCK THE FRONT

WHEELS, AND DO NOT SUBJECT THE MACHINE TO VIBRATION . TO AVOID CHEMICAL INCOMPATIBILITIES WITH THE INTERNAL COMPONENTS OF THE MACHINE,

USE ONLY OILS APPROVED BY THE VEHICLE MANUFACTURER . Problems resulting from the use of non-approved oils will void the warranty.

Additional health and safety information can be obtained from refrigerant and lubricant manufacturers .

Protective Devices

The machine is equipped with the following protective devices:

- Over pressure valves.
- A maximum pressure switch stops the compressor when excessive pressure is sensed.



WARNING: Tampering with these protective devices could result in serious injury .

Refrigerant Tank Test

Official records and recurring tests necessary for pressurized instruments are governed by laws and/or national regulations dependent upon the country where the refrigerant tank is used. The system manager is responsible for compliance with laws, regulations, and technical rules. During normal service, refrigerant tanks do not need maintenance. Refer to the Maintenance section of this manual for more information.

J2843 Requirement Regarding Lubricant

Only new lubricant, as specified by the system manufacturer, shall be installed in the MAC System. Lubricant removed from the system and/or the equipment shall be disposed of in accordance with the applicable federal, state and local procedures and regulations.

Caution Statement — Modifications

CAUTION: Any changes or modifications not expressly approved by Bosch Automotive Service Solutions may void the user's authority to operate the equipment .

This machine is used on R-134a equipped vehicles and is designed to be compatible with existing service equipment and standard service procedures. This machine is a single-pass system (i.e. refrigerant flows through a filter once) that meets specifications for recycled refrigerant. Follow recommended service procedures for the containment of R-134a. *Note: Refrigerant systems require special oils. Refer to the A/C system manufacturer's service manual for oil specifications.*



Technical Specifications

Dimensions107 cm x 56 cm x 80 cm
Display10.1 in. LCD Touchpanel
Filter68 kg (150 lb)
Humidity32.2°C (90°F), 80% RH non-condensing
ManometerØ 100 mm (3.9 in.)
Maximum Pressure27 bar (390 PSI)
Noise<70 dB(A)
Nominal Voltage115V, 60 Hz
Oil Bottle Capacity355 ml (12 oz)
Operating Temperature	...10°C to 50°C (50°F to 122°F)
Power Consumption1380 W
Vacuum Pump Free-Air Displacement1.5 CFM (42 L/m) @ 60 Hz
Service Hoses2.50 cm / SAE J2196
Tank Capacity10 kg (22 lb)
Weight73 kg (161 lb)

Introduction

Features

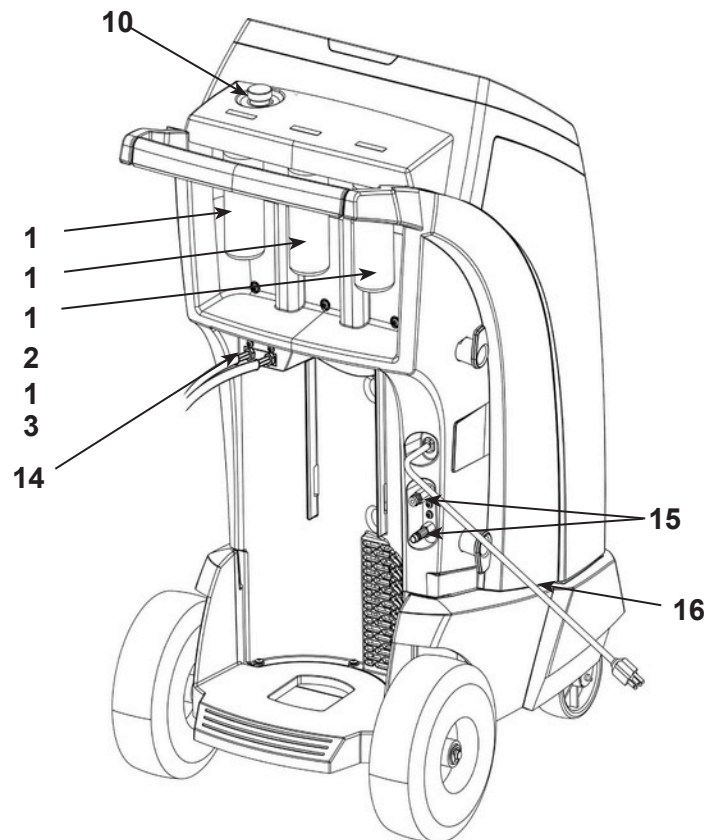
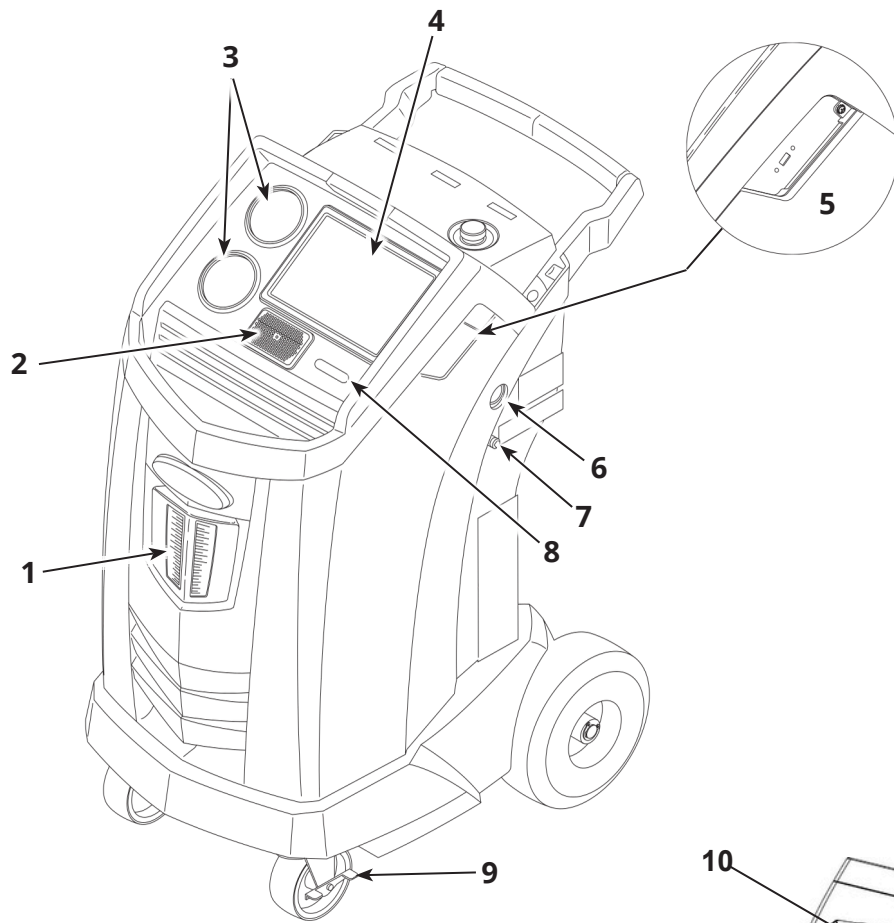

Item No .	Description
1	Oil Drain Bottle
2	Speaker
3	Low-side (blue) and High-side (red) Manifold Gauges
4	LCD Touchscreen Display
5	USB Connections (detailed view shown without protective cover)
6	Vacuum Pump Oil Sight Glass
7	Vacuum Pump Oil Drain Fitting
8	Power Switch
9	Wheel Lock
10	Vacuum Pump Oil Fill Cap and Port
11	Oil 1 Inject Bottle
12	Oil 2 Inject Bottle
13	UV Dye Inject Bottle
14	Service Hoses
15	Service Hose Storage Ports
16	Power Cord

Introduction

Icon Legend



AUTOMATIC ICON

Pressing this icon will initiate the automatic refrigerant recovery, vacuum, and charge process.



RECOVER ICON

Pressing this icon will initiate the refrigerant recovery process.



VACUUM ICON

Pressing this icon will initiate the system vacuum process.



CHARGE ICON

Pressing this icon will initiate the refrigerant charge process.



VEHICLE LOOKUP ICON

Pressing this icon will initiate the system diagnosis process.



HELP ICON

Pressing this icon will provide help and information corresponding to the current screen and/or function being viewed or performed.

BACK ICON

Pressing this icon will return to the previous screen.

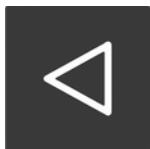

HOME ICON

Pressing this icon will return to the home screen.



RECENT APPS ICON

Pressing this icon will open a list of thumbnail images of Apps that have recently been used.



VOLUME ICON

Pressing this icon will allow the user to increase or decrease the audio volume.

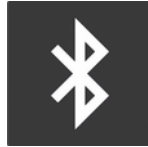

BLUETOOTH ICON

Pressing and holding this icon will allow the user to configure Bluetooth settings and connect external devices.



WIFI ICON

Pressing and holding this icon will allow the user to connect the machine to a wireless network. The connection status and relative signal strength are also indicated by this icon.



BATTERY ICON

This icon will always indicate that the unit is charging. This is a normal function caused; there is no internal battery in the unit.

Main Menu Functions

Info and Status

Displays the storage tank refrigerant capacity for recovery and charge. Also displays the quantity of system oil in each storage bottle. Recovery Capacity, Charge Capacity are also displayed in this menu.

Settings

General Settings

Displays model name and serial number and provides the following settings options:

- **Unit of Measure**
Select between imperial or metric units.
- **Date**
Displays the current date.
- **Time**
Displays the current time. User can change the time by selecting the appropriate time zone.

Software Information

Displays the current software version and publication date. Provides a notification and option to install an updated software version, if available. Displays additional software information as well as links to the release notes and license information. Open source software details can also be viewed.

Edit Print Header

Programs information that will appear on the service printout including: shop name, address, website, email, and phone number.

Printer Settings

Printing from machine will use Google Cloud Print, additional information about this can be found at <https://www.google.com/cloudprint/learn/>.

Displays current printer being used by machine as well as a drop down menu which displays available printers.

Select Language

Select a language for the screen prompts. English is the default language.

Owner's Manual

Provides link to view a PDF of the most up-to-date Owner's Manual within the browser.

Video Library

Provides links to instructional videos and product information.

Contact Robinair

Provides phone and email information for Robinair Customer, Technical, and International Service support.

Registration

Failure to register and activate the machine within 30 days of initial startup will cause the machine to lock out and no longer function. Select this Settings Menu item and follow the prompts before the trial period expires. Allows user to update registration.

Subscriptions

Displays the status of a subscription to a reference diagnostic database and provides a link to change the subscription status. This page also displays the status of subscription(s) to Service Data Uploads.

Service Data

Displays vehicle information that was entered into the Enter Service Data screen. Vehicles are displayed by date of service and VIN number.

Introduction

Setup Menu Functions

Access the following functions by selecting **SETUP MENU**.

Calibration Check

Use to verify internal scale calibration. Refer to Calibration Check in the Maintenance section of this user manual.

Filter Maintenance

The filter removes acid, particulates, and moisture from the refrigerant. The filter must be replaced after 68 kg (150 lb) of refrigerant has been filtered. This menu item displays the filter capacity remaining until the machine locks down and no longer functions. Refer to Filter Maintenance in the Maintenance section.

Flush Hoses

Flushes residual oil from the machine's service hoses to prepare for service of next vehicle.

Production Menu

For Robinair production use only.

Pump Maintenance

Displays the amount of time remaining until the next vacuum pump oil change is needed. For maximum vacuum pump performance, change vacuum pump oil every time the filter is replaced. Refer to the Change Vacuum Pump Oil in the Maintenance section.

Refrigerant Management

Displays the amount of refrigerant recovered, charged, and replenished (for the life of the machine), and filtered since the last filter change.

System Flush

Removes oil by forcing liquid refrigerant through an A/C system or components of an A/C system. After flushing, the refrigerant is recovered by the machine and filtered by the recycling circuit.

Service Menu

For Robinair service center use only.

Tank Fill

Transfers refrigerant from a source tank to the ISV. The tank fill value may be adjusted up or down to suit the user's needs. Refer to Tank Fill in the Maintenance section.

Hose Equalize

~~Recovers refrigerant~~ Recovers refrigerant from the service hoses back into the vehicle A/C system. This item is useful after performing diagnostics that do not require the need to recover the A/C system into the RRR machine. The user will be prompted to connect the low-side service hose to the appropriate port and to start the vehicle's A/C system on max.

Set Oil Inject Viscosity

Set the oil viscosity of the injection oil.

Internal Tank Status

Displays the amount of refrigerant in the tank, tank temperature, tank pressure, and the calculated saturated vapor pressure based on the temperature.

Buzzer Settings

Configures the settings on the notification buzzer. Buzzer can be switched on or off.

Adjust Zero Offset

~~Recalibrates the oil~~ Recalibrates the oil inject and dye load cells by zeroing the offsets. The system prompts the user to select to appropriate bottle and remove it before calibration.

Leak Check

Performs an internal leak check of the unit. A small quantity of refrigerant is used to charge the unit and pressure decay is monitored. The user may inspect for leaks with an external leak detector (not included). Refrigerant is recovered from the system and a vacuum is applied. Similarly, the system monitors for a change in pressure, and notifies the user if a leak is detected.

Enable Identifier

Selects when identifier prompts are displayed. There are 3 options: always display prompts, skip prompts, and ask the user to connect the identifier.

Replace Service Hoses

Removes any refrigerant remaining from the service hoses before replacement.

System Information

Displays the revision level of the software in the machine.

Boost Refrigerant

Allows the user to add incremental refrigerant to a vehicle.

Temperature Sensor Snapshot

Allows the user to select whether the internal vehicle temperature should be recorded before and after service. A wireless temperature probe must be purchased separately.

Default Vacuum Time

Allows the user to specify the default time a vehicle system is held under vacuum during a leak test.

Adjust Background Fill Target

Allows the user to adjust the desired refrigerant tank level. An external refrigerant tank must be connected to support this function.

Operating Requirements and Conditions

The design of WiFi/BT Module Card complies with U.S. Federal Communications Commission (FCC) guidelines respecting safety levels of radio frequency (RF) exposure for Mobile devices.

FCC ID

This product contains FCCID: 2AHLA-SP01500243

Mobile Device RF Exposure Statement

RF Exposure - This device is only authorized for use in a mobile application. At least 20 cm of separation distance between the WiFi/BT Module Card device and the user's body must be maintained at all times.

FCC Part 15 Statement

This equipment has been tested and found to comply with the limits for a Class A digital device, pursuant to part 15 of the FCC Rules. These limits are designed to provide reasonable protection against harmful interference when the equipment is operated in a commercial environment. This equipment generates, uses, and can radiate radio frequency energy and, if not installed and used in accordance with the instruction manual, may cause harmful interference to radio communications. Operation of this equipment in a residential area is likely to cause harmful interference in which case the user will be required to correct the interference at their own expense.

Initial Setup

Unpack the Accessory Kit

Unpack the accessory kit from the box, and remove the plastic packaging.

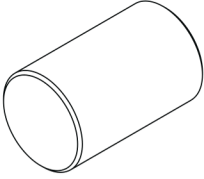
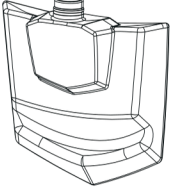
Calibration Check Weight 533 g (1.18 lb)	
Oil Drain Bottle	
Pouch containing the user manual, SDSs, EPA information, MACS information, and a service center list.	



WARNING: To prevent personal injury while working with refrigerant, read and follow the instructions and warnings in this manual, and wear protective equipment such as goggles and gloves .

IMPORTANT:

- This procedure can take several hours. Perform this initial setup procedure **BEFORE** the machine is needed for its first vehicle A/C service.
- During initial setup, the machine prompts through the following steps. Any changes to these settings after the initial setup can be completed through the Unit Setup menu.



CAUTION: The machine is programmed to run the setup procedure as outlined here . To prevent personal injury, do **NOT** operate the machine without the oil fill port installed because the vacuum pump is pressurized during **normal operation** .

Power Up the Machine

1. Unwind the power cord from the handle, and plug it into a correct voltage, grounded outlet.
Note: For best performance, do not use an extension cord with the unit.
2. Position the machine so the plug and the power switch are easily accessible to the user. Verify the fan vents on the rear of the machine are not obstructed.
3. Lock the front wheels.
4. Install the oil drain bottle.
5. Toggle the power switch on the control panel to turn the machine ON.

The machine launches into the initial Setup mode.

Select Language

The user selects the language for the screen prompt displays.

Connect to a Wireless (Wi-Fi) Network

To fully utilize the functions of this machine, a wireless connection is required. Instructions for how to connect the ACS machine to a wireless network are listed below:

1. Plug in and turn on the machine.
2. After the machine has booted up, drag down from the top edge of the screen and select to enter the Settings Application.
3. Select **NETWORK AND INTERNET** from the Setting Application and then select **WI-FI**. Verify that Wi-Fi is turned on before attempting to connect.
4. Select a wireless network from the list of available networks and enter the network password, if required. The network is now saved and will automatically be connected when the machine is on and within range of the network. The connection status will be indicated next to the network name.

Setup a Wireless Printer

A wireless printer must be connected to the machine to print information and reports. This machine uses Google Cloud Print, more information can be found at <https://www.google.com/cloudprint/learn/>. General setup instructions are given below. Please also refer to the printer manufacturer instructions for additional information to connect a wireless printer.

1. Verify both the printer and machine are turned on and connected to the same wireless network. Refer to the printer manufacturer instructions for connecting the printer to a wireless network. Refer to Connect to a Wireless Network in this manual to connect the machine.
2. After the machine has booted up, drag down from the top edge of the screen and select to enter the Settings application.
3. Select **CONNECTED DEVICES** then **PRINTING**.
4. To add a printer, select **MORE** and then select the printer.

Edit Print Header

This machine has the capability to store and print recovery, vacuum, charge, and flush information for previous vehicles

Initial Setup

serviced. The information loaded into Edit Print Header will appear on each printout.

Follow the prompts on the screen to enter the following information:

- Shop Name
- Address
- Website
- Email
- Phone number

Select Units

The user sets the display for units of measure.

Set Date and Time

Follow the screen prompts to set date and time. The user can change the time zone and time format as well as choose to have the date and time automatically updated by the network.

License Agreement

Review the license agreement and follow the prompts on the screen to continue.

Service Vacuum

At this point the machine clears its internal plumbing before proceeding with setup.

1. Check the vacuum pump oil level sight glass and verify the oil level is at the center of the sight glass.
2. When prompted, connect the service hoses from the machine to their storage ports as shown in Figure 1 and turn coupler valves clockwise to open. Follow the prompts to continue.
3. The machine enters a 5-minute vacuum and will automatically enter the next setup process when complete.

Adjust Background Fill Target

This machine possesses a background tank fill feature. An external refrigerant storage vessel can be fluidly connected to the machine (using the black tank fill hose) for a continuous topping off of the internal storage vessel. Drawing from the refrigerant within the connected external storage vessel, the machine will periodically charge the ISV tank to the desired fill target. Enter the desired fill target (default amount is 4.54 kg).



WARNING: To prevent personal injury while working with refrigerant, read and follow the instructions and warnings in this manual, and wear protective equipment such as goggles and gloves .

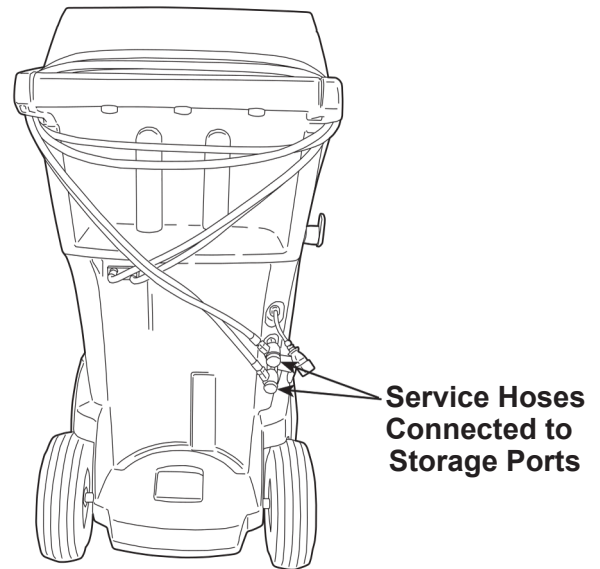

Figure 1

Tank Fill

This procedure transfers refrigerant from a source tank to the internal storage vessel (ISV) in the machine. The maximum capacity of the ISV is 10 kg (22 lb).

1. The machine displays fields for desired tank fill amount, charge capacity, and the amount of recoverable refrigerant (recover capacity) within the internal storage vessel. Enter the desired tank fill amount.
Note: Add at least 3.6 kg of refrigerant to ensure enough is available for charging.

2. Connect the tank fill (black) hose to the liquid connector on the source tank.
3. Open the source tank valve.
4. Position the source tank in such a way that liquid refrigerant is supplied to the connection.
5. Follow the screen prompts to start the tank fill process. The machine begins filling the internal storage vessel (ISV). Add at least 3.6 kg of refrigerant to ensure enough is available for charging. This process takes 15–20 minutes.
6. The machine stops when the designated amount of refrigerant has been transferred to the ISV or when the source tank is empty. Follow the messages on the display.
7. Close the source tank valve.
8. Follow the screen prompts to return to the Setup Menu.

The machine is ready for operation.

Note:

- *There is no need to calibrate the scale; it is calibrated at the factory.*
- *After the tank fill process is complete, the display does not show the same amount as the programmed fill level. The display shows the amount of refrigerant that is available for charging, which is approximately 0.67 kg (1.4 lb) less than the total amount of refrigerant in the tank.*

*Note: **Charge Capacity:** The amount of refrigerant in the ISV that can be charged into a vehicle A/C system. **Recover Capacity:** The amount of additional refrigerant that could be recovered into the ISV.*

Initial Setup

Unit Registration

Failure to register and activate the machine within 30 days of initial startup will cause the machine to lock out and no longer function.

1. After powering on the machine, follow the prompts to Register Now or Register Later.
2. Connect to a wireless network, if not already connected.
3. Select New Account, if creating a new account, otherwise select Existing Account. Follow the prompts to continue
4. Enter the required registration information including name and contact information.
5. Enter the activation code into the correct field and follow the prompts to complete the registration process.
Note: Enter the code exactly as received. Capitalization is required.

Enter Service Data

After selecting any service function, information about the vehicle may be entered into and stored in the machine's database.

Information entered on this screen is stored by date and vehicle identification number (VIN). The most recent vehicle's data appears at the top of the list. The information will also appear on service summary printouts.

Users can also look up vehicle specifications such as type of oil and quantity and type of refrigerant and quantity.

Operating Instructions



Recover Refrigerant from a Vehicle

1. Empty the oil drain bottle before starting a recovery. Remove the oil drain bottle from the machine by pulling the bottle straight down—do not use a twisting or rocking motion. Reinstall the oil drain bottle. See Figure 2. *Note: Use caution when removing/installing oil drain bottle. Excessive force may damage internal load cell.*
2. Connect the high-side (red) and low-side (blue) service hoses to the vehicle A/C system.
3. Open the coupler valves on the hoses by turning the collars clockwise.
4. Select **RECOVER**  from the **MAIN MENU**.
5. The machine will display the service data entry form. Enter all applicable data and follow prompts to continue. The machine will ask whether to record diagnostic pressures. The machine can also record refrigerant ID and temperature probe information if paired with optional accessories. The machine begins the recovery process. A clicking noise occurs when the solenoid is activated — this is normal. The machine runs a self-clearing cycle to clear any internal refrigerant from its internal plumbing.

6. After the oil drain is complete, a summary is displayed showing the total amount of refrigerant and oil recovered. After recovery, the machine will perform an oil drain. Recovery information and pre-recovery diagnostics can be printed by selecting print. *Note: The displayed recovered weight can vary depending on ambient conditions and should not be used as an indicator of scale accuracy.*

Note: The amount of oil that was removed from the A/C system is the amount of new oil that should be charged into the A/C system after evacuation is complete.

Only new lubricant, as specified by the system manufacturer, may be installed in the MAC System. Lubricant removed from the system and/or the equipment shall be disposed of in accordance with the applicable federal, state, and local procedures and regulations.



WARNING: To prevent personal injury while working with refrigerant, read and follow the instructions and warnings in this manual, and wear protective equipment such as goggles and gloves .

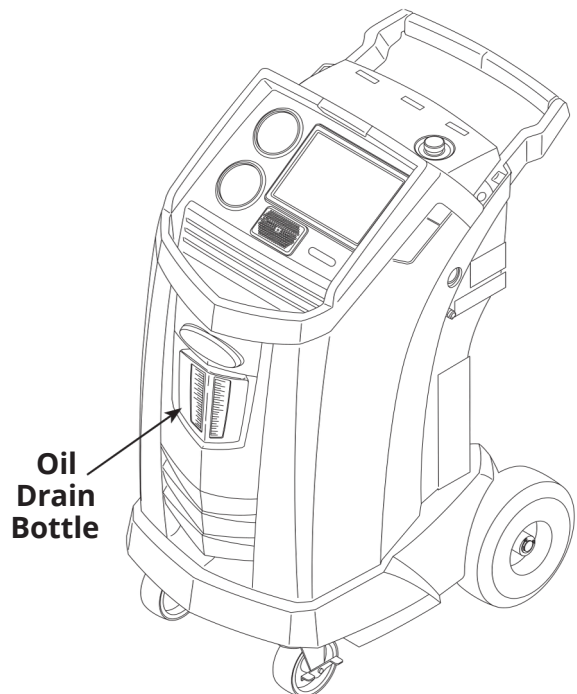

Figure 2



Evacuate the Vehicle A/C System

1. Connect the service hoses to the vehicle's service ports.
2. Open the service hose coupler valves by turning the collars clockwise.
3. Select **VACUUM**. If a vehicle has not already been selected, enter the vehicle service info and follow the prompts to continue.
4. Select Vacuum Leak Check, if desired, to automatically perform a 5-minute pressure rise leak check after the vacuum.
5. Enter the desired vacuum time and follow the prompts to continue.
Note: The vacuum process will halt if pressure rises above .35 bar (5 psi). Recover refrigerant before proceeding.

The machine pulls a vacuum on the A/C system for the programmed amount of time.

Select print to print vacuum info.



WARNING: To prevent personal injury while working with refrigerant, read and follow the instructions and warnings in this manual, and wear protective equipment such as goggles and gloves .

Operating Instructions

Flushing the Hoses

If the next vehicle to be serviced contains a different type of oil than the previous vehicle serviced, it is recommended the service hoses be flushed of residual oil to prevent contamination.

1. Select **FLUSH HOSES** from the **SETUP MENU**. Follow the prompts to connect service hoses to storage ports and open coupler valves.
2. Connect the service hoses to the machine's storage port connections shown in Figure 3.
3. Open the service hose coupler valves by turning the collars clockwise.
4. Follow the prompts to begin the hose flush process, which runs for three minutes, followed by a recovery.
5. Follow the prompts to return to the **MAIN MENU** when the hose flush is complete.
6. Close the coupler valves by turning the collars counter-clockwise.

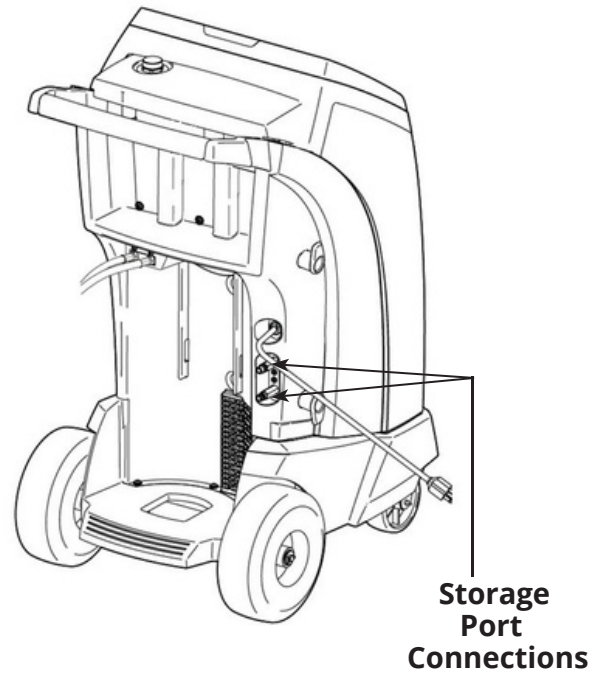



Figure 3



Recharge the Vehicle A/C System

1. Select **CHARGE**  from the **MAIN MENU**.
2. Enter service data when prompted. Follow prompts to continue.
3. Enter the desired charge amount and select the desired charge path. High Side is default.
4. Connect both service hoses to the vehicle's service ports and open coupler valves. Select proceed.
5. Oil can also be injected into the system during the charge. Enter the amount of oil to be injected, and select the appropriate bottle.
6. Follow the prompts to start the charge process. Moving or bumping the machine at this point may result in an inaccurate charge. When the charge cycle approaches the desired weight value, the machine slows down. It will charge, settle, charge again, settle, etc.
7. When prompted, follow the steps to perform hose equalization or hose compensation.
Note: Hose equalization requires the user to start the vehicle. Hose compensation adds a preset amount of refrigerant to the chart to compensate for service hose volume.
8. The user will be prompted to close the coupler valves and disconnect the hoses from the vehicle. Follow prompts to recover any remaining refrigerant from the hoses.
9. When the **CHARGE COMPLETE** screen appears, it includes a summary of charge results. The user may print the summary. Select **EXIT** to return to the **MAIN MENU**.

The vehicle A/C system is now ready for use.

Operating Instructions



Automatic Function

The **AUTOMATIC** function allows a user to perform an automatic recovery, vacuum, leak test, and/or charge sequence. A total automatic sequence may take up to an hour to complete.

1. Connect high-side (red) and low-side (blue) service hoses to the A/C system.
2. Open the service hose coupler valves by turning the collars clockwise.
3. Select **AUTOMATIC**  from the **MAIN MENU** and enter the vehicle service information.
4. Enter the desired length of vacuum.
5. Choose whether to perform a vacuum leak test. ON is the default setting.
6. Enter the desired charge amount and select the charge path. High Side is default.
7. Enter the desired additional oil inject amount. If desired, select dye inject. This will add approximately 7 mL (0.25 oz) of UV dye to the charge. Make sure there is available oil in the oil/dye inject bottle located on the rear of the machine.

The user may choose to connect an external identifier or record diagnostic pressures and temperatures.

Note: Additional oil amount specified is in addition to the amount recovered. If no additional oil is specified, the machine will inject the same amount of oil as was recovered (automatic mode only).

The unit will now automatically proceed through all applicable functions: **RECOVER**, **VACUUM**, and **CHARGE**. If the vehicle being serviced has previously undergone a recover and vacuum procedure, the machine will only perform a **CHARGE**.

8. When the process is complete a summary of results is displayed. The user may print the summary.
9. The user will be prompted to close the coupler valves and disconnect the hoses from the vehicle. Follow prompts to recover any remaining refrigerant from the hoses. Once the clear is complete, the machine will return to the Main Menu.

The vehicle A/C system is now ready to use.



WARNING: To prevent personal injury while working with refrigerant, read and follow the instructions and warnings in this manual, and wear protective equipment such as goggles and gloves .

Notes:

- The **CHARGE** function for vehicles equipped with a single-service fitting should be carried out manually according to procedures in the vehicle manufacturer's service manual. After the **RECOVER** process, the user will be prompted to check oil bottle and enter oil to be added. The amount of oil added should be equal to the amount of oil drained and can be found by looking at the graduations on the drain bottle.
- If problems are encountered during the automatic sequence, an audio alert sounds three times. The sequence remains paused until the user enters a decision regarding how to proceed.

Operating Instructions

System Flush

The **SYSTEM FLUSH** function is performed using a vehicle manufacturer-approved flushing adapter. Refer to the instructions included with the adapter while the following steps are performed.

1. Verify the flusher filter and strainer are not plugged.
2. Mount the flusher to the rear of the machine.
3. Remove the oil drain bottle (see Figure 4) from the Rob-inair machine. Drain the oil bottle, and dispose of the oil according to applicable regulations. Reinstall the oil drain bottle on the machine.
4. Recover all refrigerant from system to be flushed.
5. Note the amount of oil collected during recovery. This amount must be replaced, as well as any oil collected during flush.
Note: The amount of oil collected and reported during system flush does not include the amount of oil collected during the initial recovery.
6. Verify there are at least 6.0 kg (13.2 lb) of refrigerant in the machine. The machine will not be able to complete a system flush without at least 6.0 kg of refrigerant in the ISV. *Note: If the machine does not have at least 6.0 kg (13.2 lb) of refrigerant on-board, see the section of this manual titled Tank Fill.*

7. Disconnect the machine from the vehicle.
8. Refer to the vehicle service manual, and connect the appropriate flushing adapters and bypasses.
9. Connect the low-side (blue) service hose directly to the filter of the flushing kit.
10. Remove the high-side (red) service coupler, and connect the high-side (red) service hose to the system suction line adapter.
11. Use the supplied hose to connect the system discharge adapter to the flusher inlet.
12. Select **SYSTEM FLUSH** from the **SETUP MENU**. The unit will prompt for any service data entry, if desired. Follow the prompts to continue to the system flushing process. The user may be prompted to enter in a total Flush Time depending upon which flush process is enabled.

The machine will then automatically enter the **VACUUM** process and proceed to a leak test.

Once the vacuum and leak tests are completed, the unit will enter the actual system flushing process, followed by an oil drain.



WARNING: To prevent personal injury while working with refrigerant, read and follow the instructions and warnings in this manual, and wear protective equipment such as goggles and gloves .

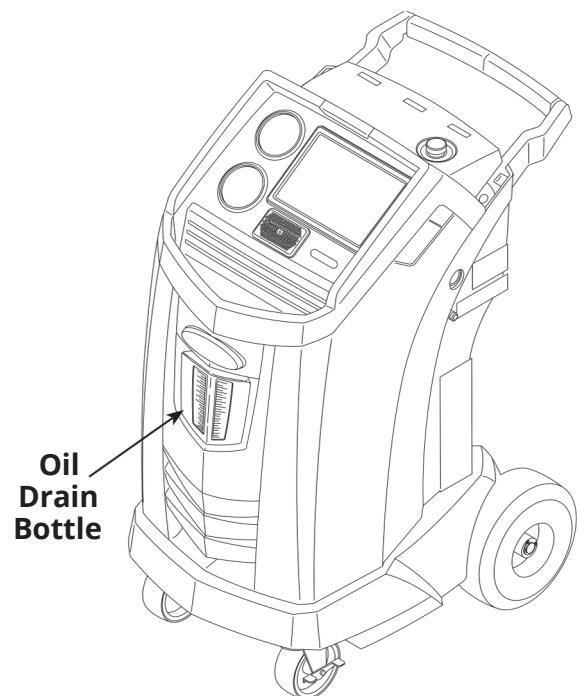



Figure 4

Operating Instructions

13. When the Flush Complete screen appears, it includes a system flush result summary. Follow the prompts to print the summary, if desired.

14. Return to the **SETUP MENU**.

The vehicle A/C system has been flushed.

 **WARNING: Do NOT disconnect service couplers during the flushing process. Refrigerant could spray out of the fittings, and exposure may cause personal injury .**

CAUTION: The flushing kit has a replaceable filter as well as a debris strainer, both of which can become clogged . At the end of the flush cycle, check the high-side (red) gauge for system pressure, and check the adapter for complete removal of refrigerant . If pressure exists or refrigerant remains, exit the flushing cycle and enter the recovery mode to recover refrigerant through both the high-side (red) and low-side (blue) hoses. Then service the filters and repeat the flush process.

Operating Instructions

Maintenance Schedule

Maintenance Task	Recommended Interval
Change filter	After 68 kg (150 lb) of refrigerant has been filtered. Refer to Filter Maintenance in the Maintenance section of this manual.
Change vacuum pump oil	When the filter is replaced. Refer to Change Vacuum Pump Oil in the Maintenance section of this manual.
Change refrigerant identifier sample hose	When filter is replaced, refer to Refrigerant Identifier section of this manual.
Check casters and wheels for ease of operation	Monthly.
Check internal scale calibration	Monthly. Refer to Calibration Check in the Maintenance section of this manual.
Check machine for leaks	Monthly. Check hoses and connections for leakage. Disconnect power, remove the shroud, and use an electronic leak detector to check fittings.
Clean airflow outlet panel (see Figure 5)	Monthly. Use a clean cloth.
Clean cabinet and control panel	Monthly. Use a clean cloth.
Inspect power cord and hoses for cuts and abrasions	Daily.
Lubricate wheel bearings and inspect brake components	Monthly.
Pressure Test	Every 10 years. Performed by an authorized Robinair service center.

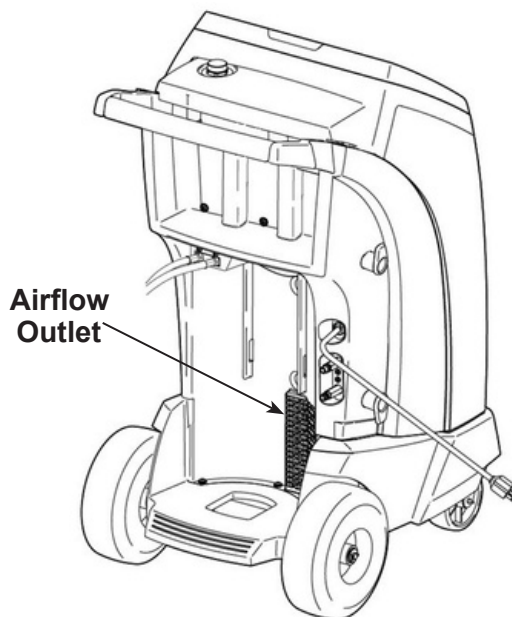

Figure 5



WARNING: To prevent personal injury only qualified personnel may perform inspections and repairs to this machine. Read and follow instructions and warnings in this manual, and wear protective equipment such as goggles and gloves.

Maintenance

Adjust Background Fill Target

This machine possesses a background tank fill feature. An external refrigerant storage vessel can be fluidly connected to the machine (using the black tank fill hose) for a continuous topping off of the internal storage vessel. Drawing from the refrigerant within the connected external storage vessel, the machine will periodically charge the ISV tank to the desired fill target.

1. Select **ADJUST BACKGROUND FILL TARGET** in the **SETUP MENU**.

2. Enter the desired fill target. Follow the prompts to save the new value, and exit.

Tank Fill

This menu item is used to transfer refrigerant from a source tank to the ISV.

The maximum capacity of the internal storage vessel (ISV) is 10 kg (22 lb). Use the arrow keys to move the cursor; use the keypad to enter a value.

Note: Add at least 3.6 kg of refrigerant to ensure sufficient refrigerant is available for charging.

1. Connect the tank fill (black) hose to the liquid connector on a full source tank.

Note: Tank fill hose and tank access port have left-handed threads.

2. Position the source tank in such a way that liquid refrigerant is supplied to the connection. Open the source tank valve and verify that the tank does not restrict airflow from the vent.

3. Select **TANK FILL** from the **SETUP MENU**.

4. Enter the quantity to recover. Add at least 3.6 kg of refrigerant to ensure sufficient refrigerant is available for charging.

5. The machine begins filling the ISV and automatically stops when the preset tank fill level is reached.

6. Once complete, close source tank valve and remove the hose from the source tank.



WARNING: To prevent personal injury while working with refrigerant, read and follow the instructions and warnings in this manual, and wear protective equipment such as goggles and gloves .

Filter Maintenance

The filter is designed to trap acid and particulates, and to remove moisture from refrigerant. To meet the mandate for adequate moisture and contaminant removal, the filter must be replaced after 68 kg (150 lb) of refrigerant has been filtered.

The machine gives a warning when 57 kg (125 lb) of the filter

capacity has been used; the machine locks down when the 68 kg (150 lb) filter capacity has been reached and will no longer function.

Check Remaining Filter Capacity

1. Select **FILTER MAINTENANCE** from the **SETUP MENU** or when the machine prompts.

The machine displays the amount of filter capacity remaining until the machine locks down.

2. Follow prompts to change the filter or cancel to resume using the machine.

WARNING: The components in the machine are under high pressure . To prevent personal injury, change the filter only when the machine prompts.



WARNING: To prevent personal injury while working with refrigerant, read and follow the instructions and warnings in this manual, and wear protective equipment such as goggles and gloves .

Maintenance

Replace the Filter

1. To change the filter, the machine requests the new filter code to be entered.

Enter the serial number that appears on the new filter, and follow prompts to continue.

Note: If "Invalid serial number" is displayed, the serial number has been incorrectly entered, or the filter has already been used in this machine. The machine clears the existing filter. Turn off the machine. Remove the oil bottle.

2. Remove the oil bottle. Remove the four screws holding the shroud. See Figure 6.

Hang the shroud on the back of the machine as shown in Figure 7.

3. Remove the filter by turning it counterclockwise (as viewed
4. from the bottom of the filter).

5. Look at the new filter. Verify both o-rings are lubricated and correctly located in the grooves.

6. Install the new filter by threading it clockwise into place.

Verify the filter is positioned correctly as shown in

7. Figure 7. Tighten the filter to 20 Nm.

Power the machine on. The Change Vacuum Pump Oil operation will begin.

See "Change Vacuum Pump Oil" on page 30 in this manual for more information.

The machine will then begin the Leak Check operation.

See the Leak Check for more information.

Caution: To prevent equipment damage, use only authentic Robinair No. 34724 filters in this machine. All performance tests and claims are based on using this specific filter.

Remove the four screws holding the shroud.

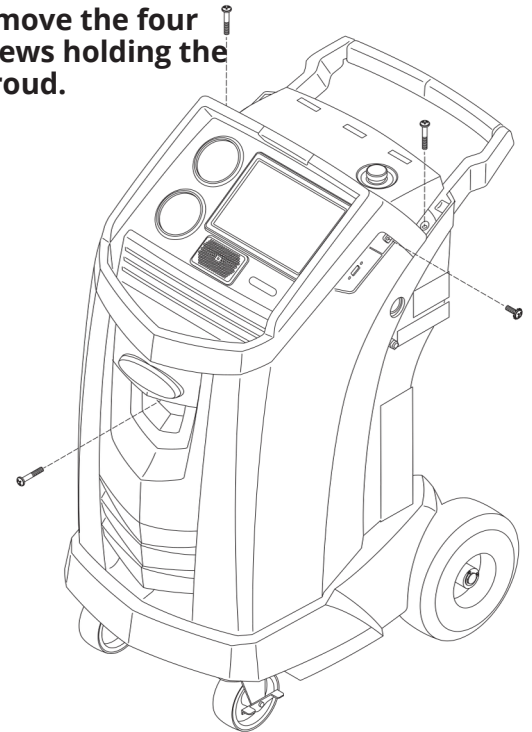

Figure 6

Hang Shroud Here

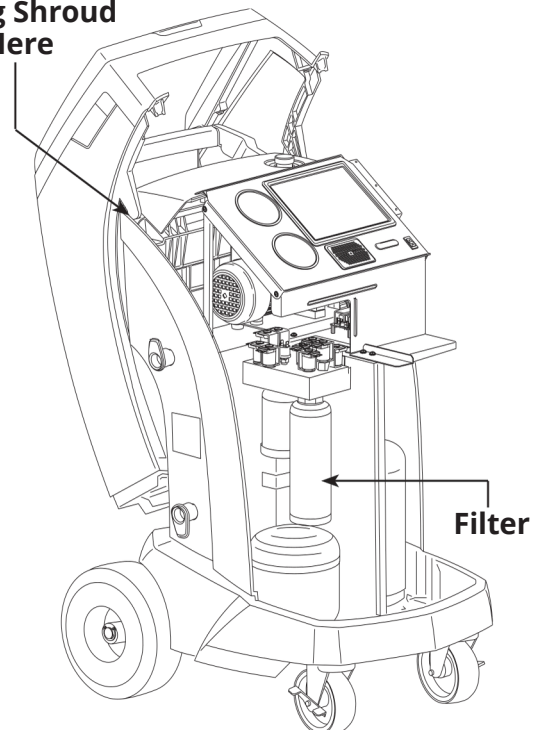
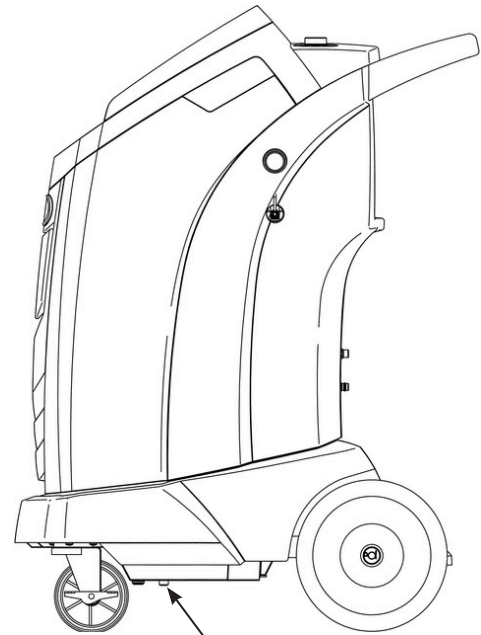

Figure 7

Calibration Check

This function is used to ensure the machine's internal scale is always calibrated. During this test, use only the calibration weight that is provided with the machine.

1. Refer to Figure 8, and verify the magnet on the bottom of the machine is clean.
2. Select **CALIBRATION CHECK** from the **SETUP MENU**.
3. Attach the calibration weight to the magnet on the bottom of the machine. Follow prompts.
4. Remove the calibration weight from the magnet. Follow prompts.
 - If the display shows "Calibration check passed" the scale is in calibration. Follow prompts to return to the Setup Menu.
 - If the display shows "Calibration check failed. Retry?" the scale is out of calibration. Follow prompts to retry. If calibration continues to fail, contact an authorized Robinair service center for assistance.



Magnet
Figure 8

Maintenance

Change Vacuum Pump Oil

1. Select **PUMP MAINTENANCE** from the **SETUP MENU** or when prompted. The display shows how long the vacuum pump has operated since the last oil change.

2. Follow prompts to change vacuum pump oil. If the machine

displays an oil warning timer, allow the vacuum pump to run for up to two minutes to warm up the oil. If the oil is already warm, follow the prompts while the compressor runs to eliminate any pressure in the vacuum pump.

3. After the compressor stops, **slowly** open the oil fill cap to verify there is no pressure in the machine. Then carefully

4. remove the cap. See Figure 9.

Remove the oil drain fitting cap and drain the oil into a suitable container for disposal. Replace the cap and close tightly.

5. Slowly add vacuum pump oil to the pump through the oil fill port until the oil reaches the center of the sight glass. Install the cap on the oil fill port and close tightly. Follow

prompts to return to the **SETUP MENU**.
Note: For proper oil level, ensure the machine is on a flat, level surface.

WARNING: To prevent personal injury, do **NOT** operate the machine at any other time without the oil fill port cap installed, because the vacuum pump is pressurized during normal operation .

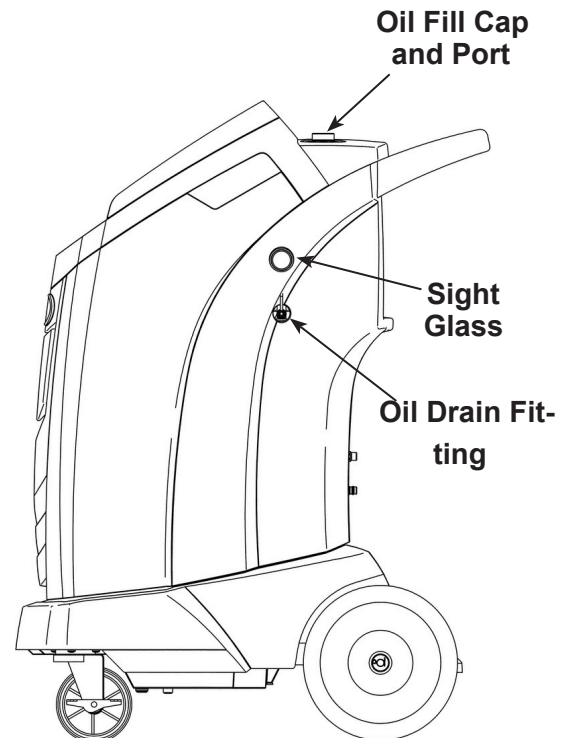

Figure 9

CAUTION: It is the responsibility of the user to monitor vacuum pump oil level and clarity . If contaminated oil is not removed from the vacuum pump and replaced, the vacuum pump will be permanently damaged .

Leak Check

A leak test may be performed on the machine at any time. During this test, components containing refrigerant are pressurized and monitored for pressure decay, which could indicate a leak.

1. Select **LEAK CHECK** from the **SETUP MENU**.
2. Connect the service hose couplers to the storage ports at the rear of the machine. Open the couplers by turning the collars clockwise.
3. Follow prompts. The machine performs a self-recovery.

The machine performs a 30-second vacuum test.

If the vacuum test fails, the machine will prompt to check for leaks.

Once the machine passes the vacuum test, a controlled pressure is applied to its internal components.

Pressure is held for five minutes and monitored for decay.

Minutes and seconds count down on the display.

- If an acceptable pressure decay is detected, the machine recovers refrigerant and returns to the Setup Menu, ready for normal operation.
- If an unacceptable pressure decay is detected, the machine will prompt to check for leaks. Take the machine to an authorized Robinair service center for repair.



WARNING: To prevent personal injury while working with refrigerant, read and follow the instructions and warnings in this manual, and wear protective equipment such as goggles and gloves .



WARNING: To prevent personal injury should the machine require transport to a local Robinair service center, follow local government regulations regarding transportation of equipment containing R134a .

Maintenance

Print a Service Record

After setting up a wireless printer, select Service Data from the Main Menu. Selected the desired vehicle service entry and follow the prompts on the screen to print.

Update Software

The user can check for available system software updates by selecting Software Information from the Settings screen on the Main Menu. A software update can be initiated by selecting the red "Update Software" icon. Alternatively, the screen will indicate if the software is up-to-date and no software update will be available.

Prior to updating the software, please ensure that the ACS unit has a strong wireless connection. Do not interrupt power during the installation process. Follow any prompts on the screen to complete the installation process.

Replacement Parts

Contact Robinair Customer Service (1-800-533-6127) for more information regarding the replacement parts listed here.

Component	Replacement Part No.
Calibration Weight Filter Oil Drain Bottle	16214
Oil/Dye Inject Bottle LP Service Coupler HP	34724
Service Coupler Service Coupler Set	19100
(high-side [red] and low-side [blue] couplers)	19103
Hose Set without Couplers	18190A
(high-side [red] and low-side [blue])	18191A
Service Hose without Coupler (low-side, blue)	18192
Service Hose without Coupler (high-side, red)	
Vacuum Pump Oil (pint)	71789
Vacuum Pump Oil (quart)	
Vacuum Pump Oil (gallon)	70020
Vinyl Dust Cover (optional)	70021
	13119
	13203
	13204
	17499

WARNING: To prevent personal injury, use only those repair parts called out in this parts list. Items found in this parts list have been carefully tested and selected by Robinair.

Glossary

A/C System

: The vehicle air conditioning system being serviced.

Evacuation : Moisture and other non-condensables are removed from an A/C system by a vacuum pump.

Internal Storage Vessel (ISV) : The refillable refrigerant storage tank designed specifically for this machine; 9.5 kg (20.94 lb) capacity.

Leak Test (Vacuum) : Components containing refrigerant are evacuated and monitored for pressure rise, which could indicate a leak.

Machine : Model No. 34998.

Leak Check : Components containing refrigerant are pressurized and monitored for pressure decay, which could indicate a leak.



Recovery / Recycling : Refrigerant is recovered from an A/C system, filtered, and stored in the ISV.

Refrigerant : R134a.

Troubleshooting Messages

Display	Cause	Solution
CALIBRATION CHECK FAILED	Internal scale is out of calibration.	<i>Retry calibration check. If calibration continues to fail, exit current test and contact a Robinair authorized service center for repair.</i>
CHARGE STALLED! CHECK CONNECTIONS AND VALVES	Refrigerant is stalled in the ISV or the machine.	<i>Verify connections are secure and valves are in correct position.</i>
DATABASE NOT INSTALLED	Machine is not shipped with database installed.	<i>Contact a Robinair authorized service center for more information.</i>
EXCESS TANK WEIGHT	Overfill safety circuit tripped. Machine is locked out because of too much refrigerant in ISV.	<i>Contact a Robinair authorized service center for more information.</i>
FILTER EXHAUSTED FILTER WEIGHT XXX.XYY REPLACE FILTER NOW?	68 kg (150 lb) or more refrigerant has been recovered since last filter change.	<i>Refer to Filter Maintenance section of this manual for instructions to change filter.</i>
HIGH PRESSURE IN ISV	Machine is locked out because pressure in ISV is too high, possibly because of excessively high tank temperature.	<i>Allow machine to cool before performing additional A/C service. If problem continues, contact a Robinair authorized service center for more information.</i>
IDENTIFY REFRIGERANT PURITY TEST FAILED	Refrigerant tested is not R-134a or it is contaminated.	<i>Do not recover contaminated refrigerant into the machine; use an external refrigerant recovery machine dedicated to contaminated refrigerant.</i>
INLET PRESSURE IS TOO HIGH FOR VACUUM	Before the machine begins evacuating the A/C system, it checks for pressure in the system that could damage the vacuum pump. In this case, system pressure is above 0.35 bar gauge.	<i>Select . Refer to Recover section of this manual to recover refrigerant before proceeding.</i>
INSUFFICIENT OIL AMOUNT TO INJECT	Oil inject bottle selected may not contain enough oil to complete the injection.	<i>Fill bottle, re-enter oil amount, or continue charge without oil inject.</i>

Troubleshooting Messages

Display	Cause	Solution
INSUFFICIENT REFRIGER- ANT. 6.00 KG REQUIRED FOR SYSTEM FLUSH	Not enough refrigerant in the ISV to perform a system flush.	<i>Refer to Tank Fill in Maintenance section of this manual.</i>
INSUFFICIENT REFRIGER- ANT AVAILABLE FOR CHARGE SELECTED: XX.XXYY AVAILABLE: XX.XXYY	After a desired weight is entered, if the charge process will leave less than 0.67 kg (1.4 lb) of refrigerant in ISV, the charge function will not start.	<i>Refer to Tank Fill in the Maintenance section of this manual.</i>
INVALID CODE	Activation code entered into the machine is not correct.	<i>Verify activation code is entered exactly as received. Capitalization is required.</i>
INVALID SERIAL NUMBER!	Filter serial number entered into the machine is not correct.	<i>Verify serial number entered matches serial number on filter. Verify filter has not been used on machine previously. Exit current test and perform repairs on vehicle A/C system.</i>
LEAK TEST FAILED	A leak in the vehicle A/C system.	<i>Verify high-side (red) and low-side (blue) hoses are connected and</i>
NO PRESSURE ON INLETS CHECK CONNECTIONS RECOVER ANYWAY?	System pressure is below 0.35 bar gauge.	<i>coupler valves open. Select  to RECOVER; select  to bypass recover and proceed to VACUUM.</i>
OIL DRAIN HALTED	Accumulator pressure failed to rise above 1.10 bar within the minute before an oil drain was supposed to occur.	<i>Adequate pressure is required within the accumulator to force the oil, which has been separated from the refrigerant, out of the system.</i>
OIL LIFE REMAINING XX- :XXX CHANGE OIL NOW?	Display shows vacuum pump oil life remaining until machine locks down.	<i>Refer to Maintenance section of this manual for instructions to change vacuum pump oil.</i>
OUT OF RANGE ACCUMULATOR PRES- SURE	Accumulator pressure transducer is not reading pressure correctly.	<i>Exit current test and contact a Robinair authorized service center for more information.</i>
OUT OF RANGE ISV PRESSURE	Internal storage vessel pressure transducer is not reading pressure correctly.	<i>Exit current test and contact a Robinair authorized service center for more information.</i>

Troubleshooting Messages

Display	Cause	Solution
OUT OF RANGE ISV TEMPERATURE	Internal storage vessel temperature sensor is not reading temperature correctly.	<i>Exit current test and contact a Robinair authorized service center for more information.</i>
OUT OF RANGE LOW SIDE PRESSURE	Low-side pressure transducer is not reading pressure correctly.	<i>Exit current test and contact a Robinair authorized service center for more information.</i>
POWER BOARD COMMUNICATION FAILED	Failed communication with relay board.	<i>Cycle power. If problem continues, contact a Robinair authorized service center for more information.</i>
PRESSURE TEST FAILED CHECK FOR LEAKS	A leak in vehicle A/C system.	<i>Exit current test and perform repairs on vehicle A/C system. Filter has already been used on</i>
SERIAL NUMBER HAS ALREADY BEEN USED	Filter serial number entered into the machine is not correct.	<i>this machine. Obtain new Robinair filter No. 34724.</i>
SOURCE TANK IS EMPTY	Refrigerant cannot be transferred to the ISV because the source tank is empty.	<i>Exit current test and replace the source tank.</i>
TANK FULL. REMOVE REFRIGERANT BEFORE CONTINUING	ISV is too full to recover additional refrigerant.	<i>Perform a charge process to remove refrigerant from ISV before any further recovery attempts.</i>
TRIAL PERIOD EXPIRED UNIT ACTIVATION REQUIRED TO CONTINUE USE	Failure to register and activate the machine within 30 days of initial startup will cause the machine to lock out and no longer function.	<i>Refer to Unit Activation section in this manual to register the machine.</i>
VACUUM TEST FAILED. CHECK FOR LEAKS	A leak in the vehicle A/C system.	<i>Exit current test and perform repairs on vehicle A/C system.</i>

Storage and Transportation of Equipment

Storage

Never leave the machine live if an immediate use is not scheduled.

1. Disconnect the machine from its power supply.
2. Loop the service hoses around the handle twice and attach them to the storage ports. See Figure 10.
3. Store the machine in a dry, stable area, away from flames and hot surfaces. The temperature of the storage area should range between -18°C and 60°C (0°F and 140°F).
4. Lock the front wheels.

Transportation of Equipment

WARNING: To prevent personal injury, should the machine require transport to a Robinair service center, follow local government regulations regarding transportation of equipment containing **R134a**.

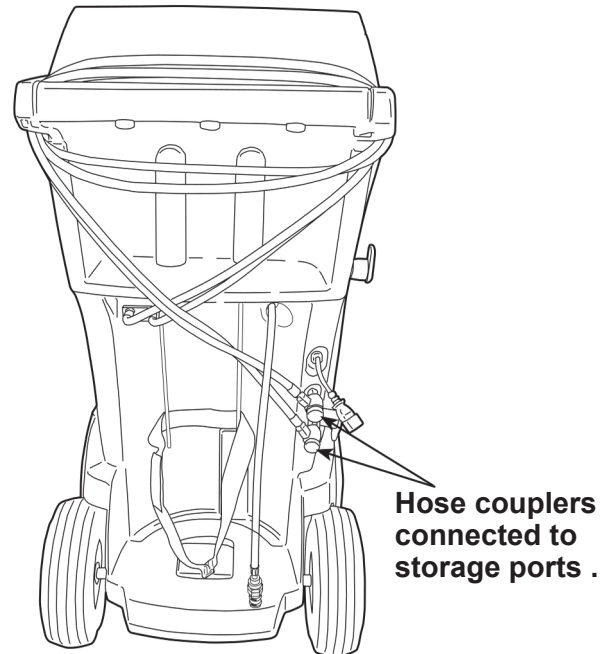

Figure 10

Disposal of Equipment



At the end of its useful life, dispose of the R134a machine according to current government regulations.

- Public administration and producers of electrical / electronic equipment (EEE) are involved in facilitating the processes of the re-use and recovery of waste electrical / electronic equipment through the organization of collection activities and the use of appropriate planning arrangements.
- Do not dispose of this equipment as miscellaneous solid municipal waste. Arrange to have it collected separately. Unauthorized disposal of waste electrical / electronic equipment is punishable by law with appropriate penalties.
- The reuse and correct recycling of electrical / electronic equipment (EEE) is required for the protection of the environment and the well-being of humans.

Disposal of Recycled Materials

It is the responsibility of the user to determine if a material is a hazardous waste at the time of disposal. The user must ensure compliance with all applicable laws and regulations.

1. Deliver the refrigerant recovered from A/C systems to gas suppliers for recycling or disposal.
2. Deliver the lubricants extracted from A/C systems to used oil collection centers.
3. Review the laws in your jurisdiction to determine correct disposal procedures for pump oil.

Disposal of the Machine

1. Detach and vent the gas from the machine circuit. Completely discharge the refrigerant tank in compliance with current government regulations.
2. Deliver the machine to an appropriate disposal center.

Disposal of Batteries



At the end of their useful life, dispose of batteries according to current government regulations. Batteries must be recycled or disposed of correctly. Do not throw away batteries as part of normal refuse disposal.



WARNING: To prevent personal injury, do not throw batteries into open flame.

CAUTION: R134a systems have special fittings (per SAE specifications) to avoid cross-contamination. Do not adapt your unit to a different refrigerant system, as failure will result.
