

MaxiSys Ultra ADAS

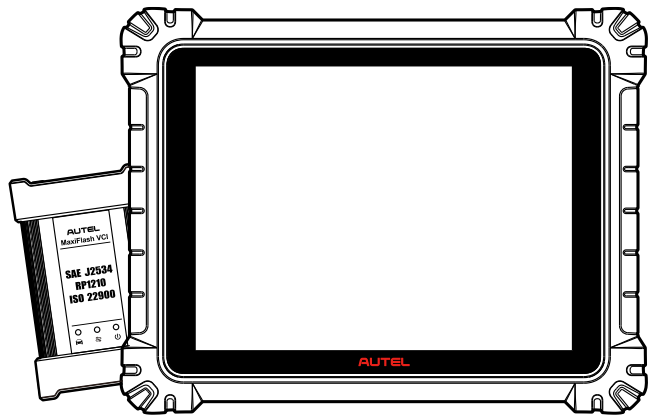

Patent

This product is protected by patents in the U.S. and elsewhere. For more information, please visit <https://autel.us/virtual-patents/>.

Trademarks

Autel®, MaxiSys®, MaxiDAS®, MaxiScan®, MaxiTPMS®, MaxiRecorder®, and MaxiCheck® are trademarks of Autel Intelligent Technology Corp., Ltd., registered in China, the United States, and other countries. All other marks are trademarks or registered trademarks of their respective holders.

Copyright Information

No part of this manual may be reproduced, stored in a retrieval system or transmitted in any form or by any means electronic, mechanical, photocopying, recording, or otherwise without the prior written permission of Autel.

Disclaimer of Warranties and Limitation of Liabilities

All information, specifications and illustrations in this manual are based on the latest information available at the time of printing.

Autel reserves the right to make changes at any time without notice. While information of this manual has been carefully checked for accuracy, no guarantee is given for the completeness and correctness of the contents, including but not limited to the product specifications, functions, and illustrations.

Autel will not be liable for any direct, special, incidental, or indirect damages, or for any economic consequential damages (including the loss of profits) as a result of using this product.

IMPORTANT

Before operating or maintaining this unit, please read this manual carefully, paying extra attention to the safety warnings and precautions.

For Services and Support



pro.autel.com

www.autel.com



1-855-288-3587 (North America)

+86 (0755) 8614-7779 (China)



support@autel.com

For technical assistance in all other markets, please refer to [Technical Support](#) in this manual.

Safety Information

For your own safety and the safety of others, and to prevent damage to the device and vehicles upon which it is used, it is important that the safety instructions presented throughout this manual be read and understood by all persons operating or coming into contact with the device.

There are numerous procedures, techniques, tools, and parts required for servicing vehicles, as well as the skills of the person doing the work. Because of the vast number of test applications and variations in the products that can be tested with this equipment, we cannot possibly anticipate or provide advice or safety messages to cover every circumstance. It is the automotive technician's responsibility to be knowledgeable of the system being tested. It is crucial to use proper service methods and test procedures. It is essential to perform tests in an appropriate and acceptable manner that does not endanger your safety, the safety of others in the work area, the device being used, or the vehicle being tested.

Before using the device, always refer to and follow the safety messages and applicable test procedures provided by the manufacturer of the vehicle or equipment being tested. Use the device only as described in this manual. Be sure to read, understand, and follow all safety messages and instructions in this manual.

Safety Messages

Safety messages are provided to help prevent personal injury and equipment damage. All safety messages are introduced by a signal word indicating the hazard level.

DANGER

Indicates an imminently hazardous situation which, if not avoided, could result in death or serious injury to the operator or to bystanders.

WARNING

Indicates a potentially hazardous situation which, if not avoided, could result in death or serious injury to the operator or to bystanders.

Safety Instructions

The safety messages herein cover situations Autel is aware of at the time of publication. Autel cannot know, evaluate or advise you as to all of the possible hazards. You must be certain that any condition or service procedure encountered does not jeopardize your personal safety.

 **DANGER**

When an engine is operating, keep the service area WELL VENTILATED or attach a building exhaust removal system to the engine exhaust system. Engines produce carbon monoxide, an odorless, poisonous gas that causes slower reaction time and can lead to serious personal injury or loss of life.

 **It is not advised to use headphones at a high volume**

Listening at high volumes for long periods of time may result in loss of hearing.

 **Safety Warnings**

- Always perform automotive testing in a safe environment.
- Wear safety eye protection that meets ANSI standards.
- Keep clothing, hair, hands, tools, test equipment, etc. away from all moving or hot engine parts.
- Operate the vehicle in a well-ventilated work area, for exhaust gases are poisonous.
- Put the transmission in PARK (for automatic transmission) or NEUTRAL (for manual transmission) and make sure the parking brake is engaged.
- Put blocks in front of the drive wheels and never leave the vehicle unattended while testing.
- Be extra cautious when working around the ignition coil, distributor cap, ignition wires and spark plugs. These components create hazardous voltages when the engine is running.
- Keep a fire extinguisher suitable for gasoline, chemical, and electrical fires nearby.
- Do not connect or disconnect any test equipment while the ignition is on or the engine is running.
- Keep the test equipment dry, clean, free from oil, water or grease. Use a mild detergent on a clean cloth to clean the outside of the equipment as necessary.
- Do not drive the vehicle and operate the test equipment at the same time. Any distraction may cause an accident.
- Refer to the service manual for the vehicle being serviced and adhere to all diagnostic procedures and precautions. Failure to do so may result in personal injury or damage to the test equipment.
- To avoid damaging the test equipment or generating false data, make sure the vehicle battery is fully charged and the connection to the vehicle DLC is clean and secure.
- Do not place the test equipment on the distributor of the vehicle. Strong electromagnetic interference can damage the equipment.

CONTENTS

1	USING THIS MANUAL	1
1.1	CONVENTIONS	1
1.1.1	Bold Text	1
1.1.2	Notes and Important Messages	1
1.1.3	Hyperlink	1
1.1.4	Illustrations	1
1.1.5	Procedures	2
2	GENERAL INTRODUCTION	3
2.1	MAXISYS TABLET	3
2.1.1	Function Description	3
2.1.2	Docking Station	5
2.1.3	Power Sources	6
2.1.4	Technical Specifications	7
2.2	MAXIFLASH VCI	8
2.2.1	Function Description	8
2.2.2	Power Sources	10
2.2.3	Technical Specifications	10
2.3	ACCESSORIES KIT	11
2.3.1	Main Cable	11
2.3.2	OBDI-Type Adapters (Optional)	11
2.4	OTHER ACCESSORIES	12
3	GETTING STARTED	13
3.1	POWER UP	13
3.1.1	Application Buttons	14

3.1.2	Locator and Navigation Buttons.....	16
3.1.3	System Status Icons.....	17
3.2	POWER DOWN.....	18
3.2.1	Reboot System.....	18
4	DIAGNOSTICS.....	19
4.1	ESTABLISH VEHICLE COMMUNICATION AND SELECTION.....	19
4.1.1	Establish Vehicle Communication.....	19
4.2	GETTING STARTED.....	24
4.2.1	Vehicle Menu Layout.....	24
4.3	VEHICLE IDENTIFICATION.....	26
4.4	NAVIGATION.....	29
4.4.1	Diagnostics Screen Layout.....	29
4.4.2	Screen Messages.....	32
4.5	DIAGNOSTICS MENU.....	32
4.6	DIAGNOSTICS FUNCTIONS.....	33
4.6.1	ECU Information.....	38
4.6.2	Trouble Codes.....	38
4.6.3	Live Data.....	40
4.6.4	Active Test.....	47
4.6.5	Special Functions.....	48
4.7	PROGRAMMING AND CODING.....	48
4.7.1	Coding.....	49
4.7.2	Reprogramming.....	50
4.7.3	Re-flash Errors.....	50
4.8	GENERIC OBDII OPERATIONS.....	51
4.8.1	General Procedure.....	51

4.8.2	Function Descriptions	52
4.9	DIAGNOSTIC REPORT	55
4.9.1	Pre-Scan and Post-Scan Functions.....	55
4.9.2	Diagnostics Report Saving, Viewing, and Sharing.....	56
4.10	EXIT DIAGNOSTICS	59
5	WHEEL ALIGNMENT	61
5.1	PREPARATORY WORK.....	61
5.2	PRECAUTIONS IN USE	61
5.3	VEHICLE COMMUNICATION AND SELECTION.....	62
5.3.1	Through the Wheel Alignment Application.....	62
5.3.2	Through the Diagnostics Application	68
5.4	WHEEL ALIGNMENT PROCEDURES	69
5.4.1	Vehicle Inspection	69
5.4.2	Preparation Work.....	77
5.4.3	Compensation	84
5.4.4	Caster/SAI/IA Angle Measurement.....	90
5.4.5	Measured Result	92
5.4.6	Alignment Guide	97
5.4.7	Post-alignment Diagnosis	103
5.4.8	ADAS Calibration.....	105
5.4.9	Overhaul Report	106
5.4.10	Wheel Alignment Report Saving and Cloud Sharing	107
5.4.11	Glossary	109
5.5	PERFORM DIAGNOSTICS FUNCTION & ADAS CALIBRATION	119
5.5.1	Before Wheel Alignment.....	119
5.5.2	After Wheel Alignment.....	119

6	ADAS CALIBRATION	120
6.1	PREPARATORY WORK.....	120
6.2	VEHICLE COMMUNICATION AND SELECTION.....	120
6.2.1	Specific ADAS Calibration Function.....	121
6.3	ADAS CALIBRATION PROCEDURES.....	122
6.3.1	Select a Situation That Needs Calibration	122
6.3.2	Required Calibration Tools	123
6.3.3	Calibration Preparations	123
6.3.4	Auxiliary Tool Positioning.....	124
7	SERVICE	125
7.1	OIL RESET SERVICE	125
7.2	ELECTRIC PARKING BRAKE (EPB) SERVICE.....	126
7.2.1	EPB Safety	126
7.3	TIRE PRESSURE MONITORING SYSTEM (TPMS) SERVICE	127
7.4	BATTERY MANAGEMENT SYSTEM (BMS) SERVICE	127
7.5	DIESEL PARTICLE FILTER (DPF) SERVICE	127
7.6	STEERING ANGLE SENSOR (SAS) SERVICE	128
8	DATA MANAGER	130
8.1	VEHICLE HISTORY	132
8.1.1	Historical Test Record	133
8.2	WORKSHOP INFORMATION.....	134
8.3	CUSTOMER.....	135
8.4	IMAGE	136
8.5	CLOUD REPORT	137
8.6	PDF FILES	137
8.7	REVIEW DATA	138

8.8	DATA LOGGING	138
8.9	UNINSTALL APPS.....	139
9	BATTERY TEST	140
9.1	MAXIBAS BT506 BATTERY TESTER	141
9.1.1	Function Description	141
9.1.2	Power Sources	142
9.1.3	Technical Specifications	142
9.2	TEST PREPARATION	143
9.2.1	Inspect the Battery	143
9.2.2	Connect the Battery Tester.....	143
9.3	IN-VEHICLE TEST.....	144
9.3.1	Battery Test	146
9.3.2	Starter Test.....	148
9.3.3	Generator Test	149
9.4	OUT-VEHICLE TEST	150
9.4.1	Test Procedure	150
9.4.2	Test Results.....	151
10	SETTINGS.....	152
10.1	UNIT	152
10.2	LANGUAGE	153
10.3	PRINT SETTINGS	153
10.3.1	Printing Operations.....	153
10.4	REPORT SETTINGS.....	154
10.5	PUSH NOTIFICATION	154
10.6	AUTO UPDATE	155
10.7	ADAS & ALIGNER SETTINGS.....	155

10.7.1	Common Settings	156
10.7.2	Calibration Frame Connection	159
10.7.3	Network Configuration	160
10.7.4	Update	162
10.7.5	Maintenance & Service	162
10.7.6	Wheel Alignment Software Settings.....	191
10.8	VEHICLE LIST	198
10.9	AUTOVID SETUP	198
10.10	COUNTRY/REGION CODE	198
10.11	SYSTEM SETTINGS	199
10.12	ABOUT	199
11	VCI MANAGER	200
11.1	WI-FI CONNECTION	201
11.2	VCI BLUETOOTH PAIRING	201
11.3	BAS BLUETOOTH PAIRING	202
11.4	VCI UPDATE.....	203
11.5	BAS UPDATE	203
12	UPDATE	204
13	SUPPORT	205
13.1	SUPPORT SCREEN LAYOUT	205
13.2	MY ACCOUNT	205
13.2.1	Personal Information.....	206
13.2.2	Update Information	206
13.2.3	Service Information.....	206
13.3	TRAINING	206
13.4	DATA LOGGING	206

13.5	FAQ.....	207
14	MAXVIEWER.....	208
15	ADAS & WHEEL ALIGNMENT FILTER.....	211
15.1	ADAS FILTER.....	211
15.2	WHEEL ALIGNMENT FILTER	213
16	MAXIVIDEO.....	215
17	QUICK LINK.....	216
18	REMOTE DESKTOP	217
18.1	OPERATIONS	217
19	USER FEEDBACK.....	219
20	AUTEL USER CENTER	220
21	MAINTENANCE AND SERVICE	222
21.1	MAINTENANCE INSTRUCTIONS.....	222
21.2	TROUBLESHOOTING CHECKLIST	223
21.3	ABOUT BATTERY USAGE	223
21.4	SERVICE PROCEDURES.....	224
21.4.1	Technical Support.....	224
21.4.2	Repair Service	226
21.4.3	Other Services.....	227
22	COMPLIANCE INFORMATION.....	228
23	WARRANTY	230

1 Using This Manual

This manual contains device usage instructions.

Some illustrations shown in this manual may contain modules and optional equipment that are not included in your system.

1.1 Conventions

The following conventions are used:

1.1.1 Bold Text

Bold text is used to highlight selectable items such as buttons and menu options.

Example:

- Tap **OK**.

1.1.2 Notes and Important Messages

1.1.1.1 *Notes*

A **NOTE** provides helpful information such as additional explanations, tips, and comments.

1.1.1.2 *Important*

IMPORTANT indicates a situation that if not avoided may result in damage to the tablet or vehicle.

1.1.3 Hyperlink

Hyperlinks are available in electronic documents. Blue italic text indicates a selectable hyperlink; blue underlined text indicates a website link or an email address link.

1.1.4 Illustrations

Illustrations used in this manual are samples, the actual testing screen may vary for each

vehicle being tested. Observe the menu titles and on-screen instructions to make correct option selection.

1.1.5 Procedures

An arrow icon indicates a procedure. Example:

- **To power down the MaxiSys tablet**
 1. Long press (press and hold) the **Power/Lock** button.
 2. Tap the **Power Off** option.
 3. Tap **OK**.

2 General Introduction

There are two main components to the MaxiSys system:

- MaxiSys Tablet — the central processor and monitor for the system.
- MaxiFlash VCI — the vehicle communication interface.

This manual describes the construction and operation of these devices and how they work together to deliver diagnostic solutions.

2.1 MaxiSys Tablet

2.1.1 Function Description

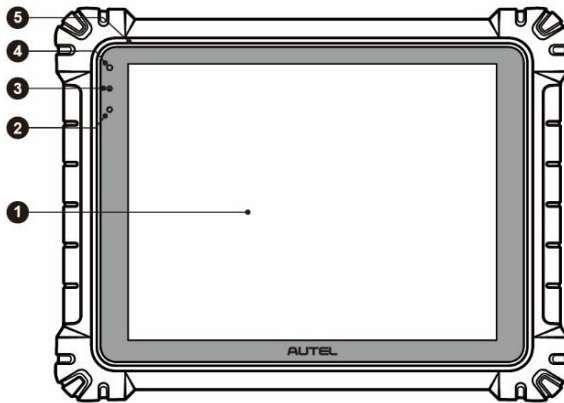

Figure 2-1 MaxiSys Tablet Front View

1. 12.7" TFT-LCD Capacitive Touchscreen
2. Ambient Light Sensor — detects ambient brightness
3. Power LED — refer to [Table 2-1 Power LED Description](#) for details
4. Front Camera
5. Built-in Microphone

Table 2-1 Power LED Description

LED	Color	Description
Power	Green	<ul style="list-style-type: none">• Lights green when the tablet is charging and the battery level is above 90%.• Lights green when the tablet is powered on and the battery level is above 15%.
	Yellow	Lights yellow when the tablet is charging and the battery level is below 90%.
	Red	<ul style="list-style-type: none">• Lights red when the tablet is powered on and the battery level is below 15%.• Lights red when the tablet shows abnormality after being powered on or during charging.

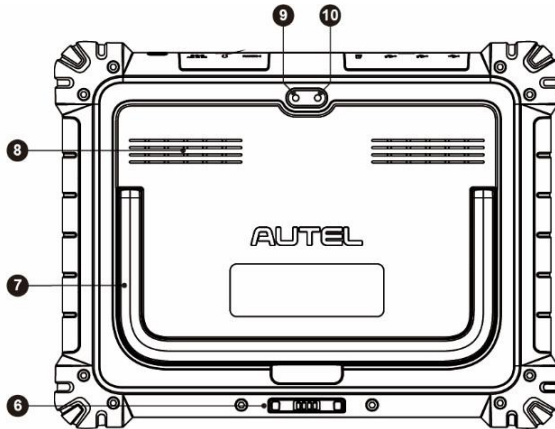

Figure 2-2 MaxiSys Tablet Back View

6. Docking Station Port
7. Collapsible Stand — extends from the back to allow hands-free viewing of the tablet
8. Speaker
9. Rear Camera
10. Camera Flash

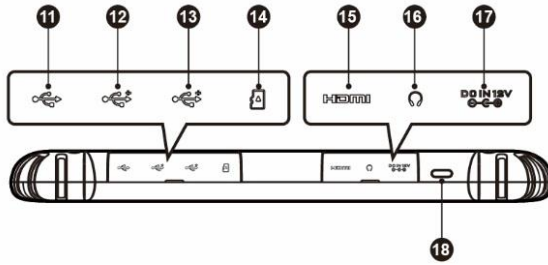

Figure 2-3 MaxiSys Tablet Top View

- 11. Mini USB Port — cannot be used with the USB Port simultaneously
- 12. USB Port
- 13. USB Port
- 14. Mini SD Card Slot
- 15. HDMI (High-Definition Multimedia Interface) Port
- 16. Head Phone Jack
- 17. DC Power Supply Input Port
- 18. Power/Lock Button — long press to turn on/off the tablet; short press to lock the screen

2.1.2 Docking Station

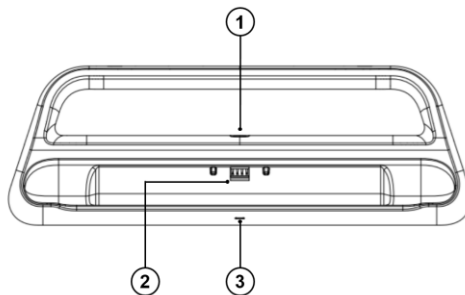

Figure 2-4 Docking Station

- 1. DC Power Port — connects to the AC/DC adapter for power supply
- 2. Charging Dock — holds the tablet for optimum viewing and convenient charging
- 3. Status Indicator Light

The indicator light displays differently in response to the tablet status described below:

- A. Green light — battery power of the tablet is sufficient ($\geq 90\%$)
- B. Yellow light — battery level is above 14% but below 90%
- C. Red light — battery level is below 14%

 **NOTE**

Ensure the docking station is clear of any small metal or other conductive parts to avoid short circuit damage to the charger and the tablet.

2.1.3 Power Sources

The tablet can receive power from any of the following sources:

- Internal Battery Pack
- AC/DC Power Supply
- Vehicle Power

 **IMPORTANT**

Do not charge the battery when the temperature is lower than 0 °C (32 °F) or higher than 45 °C (113 °F).

2.1.3.1 *Internal Battery Pack*

The tablet can be powered with the internal rechargeable battery, which if fully charged can provide sufficient power for about 8 hours of continuous operation.

2.1.3.2 *AC/DC Power Supply – using power adapter or docking station*

The tablet can be powered from an electrical outlet using the AC/DC power adapter. The AC/DC power supply also charges the internal battery pack.

2.1.3.3 *Vehicle Power*

The tablet can be powered from the auxiliary power outlet adapter or other DC power port on the test vehicle through a direct cable connection. The vehicle power cable connects to the DC power supply port on the top side of the tablet.

2.1.4 Technical Specifications

Table 2-2 Tablet Specifications

Item	Description
Operating System	Android 11
Processor	Octa-core processor (2.8 GHz)
Memory	8 GB RAM & 256 GB on-board memory
Display	12.7-inch TFT-LCD with 2732 x 2048 resolution & capacitive touchscreen
Connectivity	<ul style="list-style-type: none"> ● Wi-Fi x 2 (802.11 a/b/g/n/ac/ax 2x2 MIMO) ● BT V5.0 + EDR ● GPS ● USB 2.0 (Two USB host Type A, one USB mini device) ● HDMI 2.0 ● SD Card (support up to 256 GB)
Camera	<ul style="list-style-type: none"> ● Rear: 16 Megapixel, autofocus with flashlight ● Front: 16 Megapixel
Sensors	<ul style="list-style-type: none"> ● Gravity Accelerometer ● Ambient Light Sensor (ALS)
Audio Input / Output	<ul style="list-style-type: none"> ● Microphone ● Dual speakers ● 3-band 3.5 mm stereo/standard headset jack
Power and Battery	<ul style="list-style-type: none"> ● 18000 mAh 3.8 V lithium-polymer battery ● Charging via 12 V AC/DC power supply with the temperature between 0 °C (32 °F) and 45 °C (113 °F)
Input Voltage	12 V/3 A adapter
Operating Temp.	0 °C to 50 °C (32 °F to 122 °F)
Storage Temp.	-10 °C to 60 °C (14 °F to 140 °F)
Dimensions (W x H x D)	366.5 mm (14.43") x 280.9 mm (11.06") x 34 mm (1.34")

Item	Description
Weight	2.06 kg (4.53 lbs.)
Protocols	PLC J2497, ISO-15765, SAE-J1939, ISO-14229 UDS, SAE-J2411 Single Wire Can (GMLAN), ISO-11898-2, ISO-11898-3, SAE-J2819 (TP20), TP16, ISO-9141, ISO-14230, SAE-J2610 (Chrysler SCI), UART Echo Byte, SAE-J2809 (Honda Diag-H), SAE-J2740 (GM ALDL), SAE-J1567 (CCD BUS), Ford UBP, Nissan DDL UART with Clock, BMW DS2, BMW DS1, SAE J2819 (VAG KW81), KW82, SAE J1708, SAE-J1850 PWM (Ford SCP), SAE-J1850 VPW (GM Class2), ISO 13400, CAN FD

Table 2-3 Docking Station Specifications

Item	Description
Input Voltage	DC 12 V/3 A
Operating Temp.	0 °C to 45 °C (32 °F to 113 °F)
Storage Temp.	-20 °C to 60 °C (-4 °F to 140 °F)
Dimensions (W x H x D)	396 mm (15.59") x 136 mm (5.35") x 54 mm (2.13")
Weight	0.98 kg (2.16 lbs.)

2.2 MaxiFlash VCI

2.2.1 Function Description

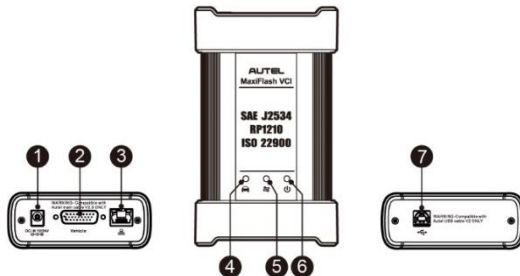

Figure 2-5 MaxiFlash VCI Programming Device

1. DC Power Supply Input Port
 2. Vehicle Data Connector
 3. Ethernet Port
 4. Vehicle LED
 - Flashes green when the device is communicating with the vehicle system
 5. Connection LED
 - Lights solid green when the device is properly connected with the tablet via the USB cable
 - Lights solid cyan (blue and green) when connected via Wi-Fi; lights solid blue when connected via Bluetooth connection
 6. Power LED
 - Lights solid green when powered on
 - Flashes red when VCI is upgrading
 - Lights solid red when a system failure occurs
 - Lights yellow automatically at power up when VCI is self-testing
 7. USB Port
-

ⓘ IMPORTANT

Do not disconnect the programming device while the vehicle LED status light is on. If the flash programming procedure is interrupted while the vehicle's ECU is blank or only partially programmed, the module may be unrecoverable.

2.2.1.1 *Programming Capability*

The MaxiFlash VCI device is a D-PDU, SAE J2534 & RP1210 compliant PassThru programming interface device. Using the updated OEM software, it is capable of replacing the existing software/firmware in the Electronic Control Units (ECU), programming new ECUs, and fixing software-controlled drivability issues and emission issues.

2.2.1.2 *Communication Capability*

The MaxiFlash VCI device supports Bluetooth (BT), Wi-Fi, and USB communications. It can transmit vehicle data to the tablet with or without a cable connection. In open areas, the working range of the transmitter through Bluetooth communication is up to 328 feet (about 100 m). The working range of 5G Wi-Fi is up to 164 feet (50 m). If the signal is lost due to being taken out of range, once the tablet is within range again, the communication will be restored.

2.2.2 Power Sources

The VCI device can receive power from the following sources:

- Vehicle Power
- AC/DC Power Supply

2.2.2.1 Vehicle Power

The VCI device operates on 12/24 volts vehicle power, which receives power via the vehicle data connection port. The device powers on whenever it is connected to an OBDII/EOBD compliant Data Link Connector (DLC). For non-OBDII/EOBD compliant vehicles, the device can be powered from an auxiliary power outlet adapter or other suitable power port on the test vehicle using the auxiliary power cable.

2.2.2.2 AC/DC Power Supply

The VCI device can be powered from a wall socket using the AC/DC power adapter.

2.2.3 Technical Specifications

Table 2-4 MaxiFlash VCI Specifications

Item	Description
Communications	<ul style="list-style-type: none">● Bluetooth V2.1 + EDR● USB 2.0● Wi-Fi 5G● Ethernet
Wireless Frequency	5 GHz
Input Voltage Range	12 V DC to 24 V DC
Supply Current	<ul style="list-style-type: none">● 170 mA @12 V DC● 100 mA @ 24 V DC
Operating Temp.	0 °C to 50 °C (32 °F to 122 °F)
Storage Temp.	-10 °C to 60 °C (14 °F to 140 °F)
Dimensions (W x H x D)	86 mm (3.38") x 149 mm (5.87") x 35 mm (1.28")
Weight	0.29 kg (0.64 lbs)

2.3 Accessories Kit

2.3.1 Main Cable

The VCI device can be powered through the Autel main cable V2.0 (the V2.0 icon can be seen on the cable) when connected to an OBDII/EOBD compliant vehicle. The main cable connects the VCI device to the vehicle's Data Link Connector (DLC), through which the VCI device can transmit vehicle data to the tablet.

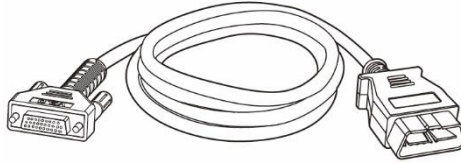









Figure 2-6 Main Cable V2.0



NOTE

The MaxiFlash VCI can only be connected by the Autel main cable V2.0. DO NOT use other Autel main cables to connect the MaxiFlash VCI.







2.3.2 OBDI-Type Adapters (Optional)

The optional OBDI-type adapters are for non-OBDII vehicles. The adapter used depends on the type of vehicle being tested. The most common adapters are shown below. (Adapters are sold separately. Please contact your distributor for details.)

 Benz-14	 Chrysler-16	 BMW-20	 Nissan-14
 Kia-20	 Fiat-3	 PSA-2	 Mazda-17

 <p>Volkswagen/ Audi-2+2</p>	 <p>Benz-38</p>	 <p>Mitsubishi/ Hyundai-12+16</p>	
---	--	--	--

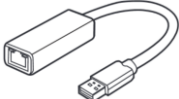
2.4 Other Accessories

	<p>USB 2.0 Cable V2 (the V2 icon can be seen on the cable)</p> <p>Connects the tablet to the VCI device.</p>
	<p>AC/DC Adapter (12 V)</p> <p>Connects the tablet to the external AC/DC power port for power supply.</p>
	<p>Auxiliary Power Outlet Adapter</p> <p>Provides power to the tablet or the VCI device through connection to the vehicle's auxiliary power outlet adapter receptacle, as some non-OBDII vehicles cannot provide power via the DLC connection.</p>
	<p>Clamp Cable</p> <p>Provides power to the tablet or the VCI device through connection to the vehicle's battery.</p>
	<p>USB to Ethernet Adapter</p> <p>Network connection function can be realized through this device.</p>
	<p>Lighter Fuse x2</p> <p>A safety device for the auxiliary power outlet adapter.</p>

3 Getting Started

Make sure that the tablet has sufficient power or is connected to the external power supply (see [Power Sources](#)).

3.1 Power Up

Long press (press and hold) the **Power/Lock** button on the top-right side of the tablet to switch the unit on. Swipe up from the bottom of the Lock screen to enter the MaxiSys Job Menu screen.

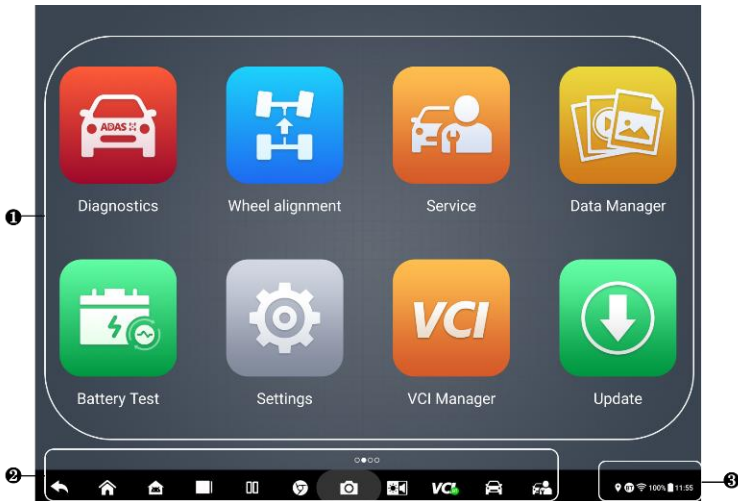

Figure 3-1 MaxiSys Job Menu

1. Application Buttons
2. Locator and Navigation Buttons
3. Status Icons

NOTE









It is recommended that you lock the screen when not in use to protect information in the system and conserve the power.

Almost all operations on the tablet are controlled through the touchscreen. The touchscreen navigation is menu-driven, allowing for quick access to the test procedure or the data that you need, through a series of questions and options. Detailed descriptions of the menu structures are found in the chapters for each application.

3.1.1 Application Buttons

The table below briefly describes each of the applications in the MaxiSys system.

Table 3-1 Applications









Button	Name	Description
	Diagnostics	Accesses the diagnostics functions. See Diagnostics .
	Wheel Alignment	Accesses the wheel alignment functions. See Wheel Alignment .
	Service	Accesses special functions menu. See Service .
	Data Manager	Accesses the saved repair shop, customer and vehicle data including detailed vehicle diagnostics and test records. See Data Manager .
	Battery Test	Accesses the Battery Test menu with two functions, including in-vehicle test and out-vehicle test. See Battery Test .
	Settings	Accesses the system settings menu and general tablet menu. See Settings .
	VCI Manager	Accesses VCI connection menu. See VCI Manager .
	Update	Accesses system software update menu. See Update .
	MaxiTools	Includes Log collection and Factory data reset two parts.



Button	Name	Description
	Support	Synchronizes Autel's online service database with the MaxiSys tablet. See Support .
	OEM Authorization	Manages the permissions for unlocking the OE gateway.
	Demonstration	Provides step-by-step operation demonstration for diagnostics.
	MaxiViewer	Provides a quick search for supported functions and/or vehicles. See MaxiViewer .
	ADAS & Wheel Alignment Filter	Includes two functions: ADAS filter and Wheel Alignment Filter. See ADAS & Wheel Alignment Filter .
	MaxiVideo	Configures the unit to operate as a video scope device by connecting to an imager head cable for close vehicle inspections. See MaxiVideo .
	Quick Link	Provides associated website bookmarks to allow quick access to product update, service, support, and other information. See Quick Link .
	Remote Desktop	Configures your tablet to receive remote support using the TeamViewer application. See Remote Desktop .
	User Feedback	You can submit feedback through this application when you encounter problems during the use of the tablet. See User Feedback .
	Autel User Center	Allows users to register Autel tool for downloading the latest released software. See Autel User Center .

3.1.2 Locator and Navigation Buttons

Operations of the Navigation buttons at the bottom of the screen are described in the table below:

Table 3-2 Locator and Navigation Buttons

Icon	Name	Description
	Locator	Indicates the location of the screen. Swipe the screen left or right to view the previous or next screen.
	Back	Returns to the previous screen.
	MaxiSys Home	Returns to MaxiSys Job Menu.
	Android Home	Returns to Android system home screen.
	Recent Apps	Displays a list of applications that are currently running. Tap an app icon to launch. Close a running application by swiping it to the top. Or close all running applications by tapping Clear All .
	Split Screen	Tap it to display a split screen.
	Browser	Launches the Chrome Internet browser.
	Camera	Tap the Camera icon to open camera viewfinder. Press and hold the icon to capture a screenshot of the display screen. The saved files are auto-stored in the Data Manager application for later review. See Data Manager .
	Display & Sound	Adjusts the brightness of the screen and the volume of the audio output.

Icon	Name	Description
	VCI Shortcut	Opens the VCI Manager application. A green icon at the bottom-right corner indicates the VCI device is connected, while a red “X” icon will be displayed if the connection fails.
	MaxiSys Shortcut	Returns to the Diagnostics screen.
	Service Shortcut	Returns to the Service screen.

➤ **To use the camera**

1. Tap the **Camera** icon. The camera screen opens.
2. Focus the image to be captured in the viewfinder.
3. Tap the **camera** icon on the right side of the screen. The viewfinder now shows the captured picture and auto-saves the taken photo.
4. Tap the thumbnail image on the top-right corner of the screen to view the stored images.
5. Tap the **Back** or **Home** button to exit the camera application.

 **NOTE**

After swiping the camera screen from left to right, the camera mode and video mode can be switched by tapping the **Camera** icon or **Video** icon.

3.1.3 System Status Icons

Your MaxiSys tablet is a fully functional Android tablet with the standard Android operating system status icons. Refer to Android documentation for additional information.

3.2 Power Down

All vehicle communications should be terminated before shutting down the tablet. A warning message displays if a shutdown is attempted while the tablet is communicating with the vehicle. Forcing a shutdown while the tablet is communicating with the vehicle may lead to ECU errors on some vehicles. Please exit the Diagnostics application before shutting off the tablet.

➤ **To power down the MaxiSys tablet**

1. Long press (press and hold) the **Power/Lock** button.
2. Tap the **Power Off** option.
3. Tap **OK**.

3.2.1 Reboot System

In case of a system crash, long press the **Power/Lock** button and tap **Restart** to reboot the system.

4 Diagnostics

The Diagnostics application can access the electronic control module of multiple vehicle control systems, including but not limited to the engine, transmission, antilock brake system (ABS), and airbag system (SRS).

4.1 Establish Vehicle Communication and Selection

4.1.1 Establish Vehicle Communication

The Diagnostics operations require connecting the MaxiSys tablet to the test vehicle through the VCI device using the main cable. (Use the applicable OBD I-type adapter if needed.) To establish a proper vehicle communication with the tablet, you need to perform the following steps:

1. Connect the VCI device to the vehicle's DLC for both communication and power supply.
2. Connect the VCI device to the tablet via Bluetooth pairing, Wi-Fi, or USB connection.
3. When the above steps are completed, check the VCI Manager Shortcut at the bottom of the screen. If a green BT, Wi-Fi, or USB icon displays at the lower-right corner, the MaxiSys tablet is ready to start vehicle diagnosis.

4.1.1.1 *Vehicle Connection*

The method used to connect the VCI device to a vehicle's DLC depends on the vehicle's configuration as follows:

- A vehicle equipped with an On-board Diagnostics Two (OBDII) management system supplies both communication and 12-volt power through a standardized J-1962 DLC.
- A vehicle not equipped with an OBDII management system supplies communication through a DLC connection, and in some cases supplies 12-volt power through the auxiliary power outlet adapter receptacle or a connection to the vehicle battery.

OBDII Vehicle Connection

This type of connection only requires the main cable without any additional adapter.

➤ **To connect to an OBDII vehicle**

1. Connect the main cable's female adapter to the Vehicle Data Connector on the VCI device, and tighten the captive screws.
2. Connect the cable's 16-pin male adapter to the vehicle's DLC, which is generally located under the vehicle dashboard.

🔧 **NOTE**

The vehicle's DLC is not always located under the dashboard. Refer to the user manual of the test vehicle for additional connection information.

Non-OBDII Vehicle Connection

This type of connection requires both the main cable and a required OBDI adapter for the specific vehicle being serviced.

There are three possible conditions for non-OBDII vehicle connection:

- DLC connection supplies both communication and power.
- DLC connection supplies communication, and power is to be supplied via the auxiliary power outlet adapter connection.
- DLC connection supplies communication, and power is to be supplied via connection to the vehicle battery.

➤ **To connect to a non-OBDII vehicle**

1. Connect the main cable's female adapter to the Vehicle Data Connector on the VCI device, and tighten the captive screws.
2. Locate the required OBDI adapter and connect its 16-pin jack to the main cable's male adapter.
3. Connect the attached OBDI adapter to the vehicle's DLC.

🔧 **NOTE**

Some vehicles may have more than one adapter or may have test leads instead of an adapter. Make the proper connection to the vehicle's DLC as required.

➤ **To connect the auxiliary power outlet adapter**

1. Plug the DC power connector of the auxiliary power outlet adapter into the DC power supply input port on the device.
2. Connect the male connector of the auxiliary power outlet adapter into the vehicle's auxiliary power outlet adapter receptacle.

➤ **To connect the clamp cable**

1. Connect the tubular plug of the clamp cable to the male connector of the auxiliary power outlet adapter.

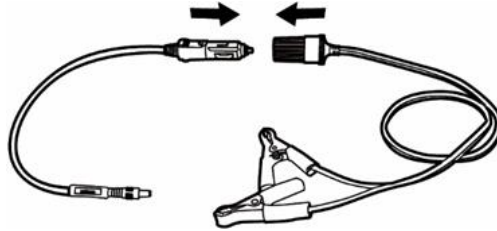

Figure 4-1 Connection Between Auxiliary Power Outlet Adapter and Clamp Cable

2. Plug the DC power connector of the auxiliary power outlet adapter into the DC power supply input port of the VCI device.
3. Connect the clamp cable to the vehicle's battery.

4.1.1.2 VCI Connection

After the VCI device is properly connected to the vehicle, the Power LED on the VCI device lights solid green and a beep sound will be heard, indicating it is ready to establish a communication with the tablet.

Coming with the MaxiSys tablet tool kit, the VCI device supports three communication methods with the tablet: Bluetooth, Wi-Fi, and USB cable.

Pairing Up via Bluetooth

In open areas, the working range for Bluetooth communication is about 328 feet (100 m), giving technicians greater mobility to perform vehicle diagnosis from anywhere in the repair shop.

To expedite multi-vehicle diagnostics, more than one VCI can be used in busy repair shops, enabling technicians to quickly pair their MaxiSys tablet to each VCI via Bluetooth separately, therefore eliminating the need to unplug the VCI from one vehicle and then connect it to another each time.

➤ **To pair the tablet with the VCI device via Bluetooth**

1. Power up the tablet.
2. Select the **VCI Manager** application from the MaxiSys Job Menu.
3. Select **VCI BT** from the connection mode list and tap the Bluetooth toggle to turn it **ON**. The device automatically scans for available VCI devices for

Bluetooth pairing. The found devices are listed in the setting section on the bottom-right of the screen.

 **NOTE**

If no VCI device is found, this may indicate that the signal strength is too weak to be detected. Reposition the VCI device and remove all possible objects that may cause signal interference. Tap the **Scan** button at the top-right corner of the screen to rescan for VCI devices.

4. Typically, the VCI device name displays as “Maxi” suffixed with a serial number. Select the VCI device for pairing. (If more than one VCI is used, ensure the correct VCI is selected to pair.)
5. When the pairing is successful, the connection status displays as “Connected.”
6. The VCI Manager Shortcut on the bottom of the screen displays a green circle BT icon when the tablet and the VCI are connected.

Refer to [VCI Bluetooth Pairing](#) for additional information.

Wi-Fi Connection

The VCI device supports 5 GHz Wi-Fi connection. In open areas, the working range of 5G Wi-Fi communication is up to 164 feet (50 m).

➤ **To pair the tablet with the VCI device via Wi-Fi**

1. Power up the tablet.
2. Select the **VCI Manager** application from the MaxiSys Job Menu.
3. Select **Wi-Fi** from the connection mode list and tap the Wi-Fi toggle to turn it **ON**. The tablet automatically scans for available VCI devices for Wi-Fi connection. Found VCI devices are listed in the setting section on the bottom-right of the screen.
4. Typically, the VCI device name displays as “Maxi” suffixed with a serial number. Select the required device for connection.
5. When the pairing is successful, the connection status is shown as “Connected.”
6. The VCI Manager Shortcut on the bottom of the screen displays a green circle Wi-Fi icon when the tablet and the VCI are connected.

Refer to [Wi-Fi Connection](#) for additional information.

USB Cable Connection

The USB cable connection is a simple and quick way to establish a communication between the tablet and the VCI device. After properly connecting the USB cable from the tablet to the VCI device, the VCI Manager Shortcut on the bottom of the screen displays

a green check mark and the Connection LED on the VCI device lights solid green, indicating the connection between the devices is successful. The MaxiSys diagnostics tablet is now ready to perform vehicle diagnosis.

 **NOTE**

Since the USB connection provides the most stable communication and is therefore the recommended communication method between the tablet and VCI when operating ECU programming or coding. The USB communication method will take priority over other connected communication methods.

4.1.1.3 *No Communication Message*

- A. If the tablet is unable to connect to the VCI, an “Error” message displays. An “Error” message indicates the tablet is not communicating with the VCI device. Troubleshoot the error by performing the following steps:
- Ensure the VCI device is powered on.
 - When using the wireless connection, ensure the network is configured correctly and the proper device has been connected.
 - If the tablet loses communication abruptly during the diagnosis, ensure no objects are causing signal interruption.
 - Ensure the VCI device is properly positioned with the VCI front side up.
 - Move the tablet closer to the VCI device. If using the wired connection, ensure the cable is securely attached to the VCI.
 - Ensure the VCI communication mode is lit for the selected communication type: Bluetooth, Wi-Fi, or USB cable.
- B. If the VCI device is unable to establish a communication link, a message will display troubleshooting instructions. Possible causes for the communication error include:
- The VCI device is unable to establish a communication link with the vehicle.
 - A vehicle system has been selected for diagnosis that is not supported by the vehicle.
 - There is a loose connection.
 - There is a blown vehicle fuse.
 - The vehicle or the data cable has a wiring fault.
 - There is a circuit fault in the data cable or adapter.
 - The vehicle identification is incorrectly entered.

4.2 Getting Started

Prior to first use of the Diagnostics application, ensure the VCI device is properly connected to and is communicating with the tablet. See [Establish Vehicle Communication](#) for further details.

4.2.1 Vehicle Menu Layout

When the VCI device is properly connected to the vehicle via the main cable, and paired to the tablet, the platform is ready to start vehicle diagnosis. Tap the **Diagnostics** application button on the MaxiSys Job Menu. The Vehicle Menu displays on the screen.













Figure 4-2 Vehicle Menu Screen

1. Top Toolbar Buttons
2. Manufacturer Icons

4.2.1.1 Top Toolbar Buttons

The operations of the toolbar buttons at the top of the screen are listed and described in the table below:

Table 4-1 Top Toolbar Buttons

Button	Name	Description
	Home	Returns to the MaxiSys Job Menu.
	VID	Tap this button to open a dropdown list: <ul style="list-style-type: none"> • Tap Auto Detect for auto VIN detection. • Tap Manual Input to enter VIN code or license number manually. • Tap Scan VIN/License to scan the VIN code/license number by camera.
	All	Displays all the vehicle makes in the vehicle menu.
	Favorites	Displays user-selected favorite vehicle makes.
	History	Displays the stored test vehicle history records. This option provides direct access to the previously tested vehicle recorded during previous test. See Vehicle History .
	America	Displays the American vehicle menu.
	Europe	Displays the European vehicle menu.
	Asia	Displays the Asian vehicle menu.
	China	Displays the Chinese vehicle menu.
	Search	Tap inside the search field to display a virtual keyboard and input the vehicle manufacturer to test.

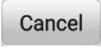
Button	Name	Description
	Cancel	Tap this button to exit the search screen or to cancel an operation.

4.2.1.2 *Manufacturer Icons*

The manufacturer icons display the various vehicle brands. Select the manufacturer icon after the VCI device is properly connected to the test vehicle to start a diagnostic session.

4.3 Vehicle Identification

The MaxiSys diagnostic system supports five methods of vehicle identification.

1. Auto Detect
2. Manual Input
3. Scan VIN/License
4. Manual Vehicle Selection
5. OBDII Direct Entry

4.3.1.1 *Auto Detect*

The MaxiSys diagnostic system features the latest VIN-based Auto Detect function to identify CAN vehicles with just one tap, enabling the technician to quickly identify the exact vehicle and scan its available systems for fault codes.

➤ **To perform Auto Detect**

1. Tap the **Diagnostics** application button from the MaxiSys Job Menu. The Vehicle Menu displays.
2. Tap the **VID** button on the top toolbar. Select **Auto Detect**. The tablet starts VIN scanning on the vehicle's ECU. Once the test vehicle is successfully identified, the system will guide you to the Diagnostics Main Menu screen.



Figure 4-3 VID Screen

4.3.1.2 Manual Input

For vehicles that do not support the Auto Detect function, the MaxiSys diagnostic system allows you to enter the vehicle VIN or license number manually, or simply take a photo of the VIN sticker or license plate for quick vehicle identification.

➤ **To perform Manual Input**

1. Tap the **Diagnostics** application button from the MaxiSys Job Menu. The Vehicle Menu displays.
2. Tap the **VID** button on the top toolbar.
3. Select **Manual Input**.
4. Tap the input box and enter the correct VIN code or license number.
5. Tap **OK**. The vehicle will be identified and matched to the vehicle database, and the system will guide you to the Diagnostics Main Menu screen.

4.3.1.3 Scan VIN/License

Tap **Scan VIN/License** in the dropdown list (see [Figure 4-3 VID Screen](#)), the camera will be opened. On the right side of the screen, from top to bottom, three options are available: **Scan Bar Code**, **Scan VIN**, and **Scan License**.

ⓘ **NOTE**

The method of Scan License is supported in some countries and areas. Please manually input the license number if it is not available.

Select one of three options and position the tablet to align the VIN or license number within the scanning window, the result displays in the Recognition result dialog box after scanned. Tap **OK** to confirm the result, and then the vehicle information confirmation screen will display on the tablet. If all the vehicle information is correct, tap the icon in the middle of the screen to confirm the VIN of the vehicle being tested, tap **OK** to continue.

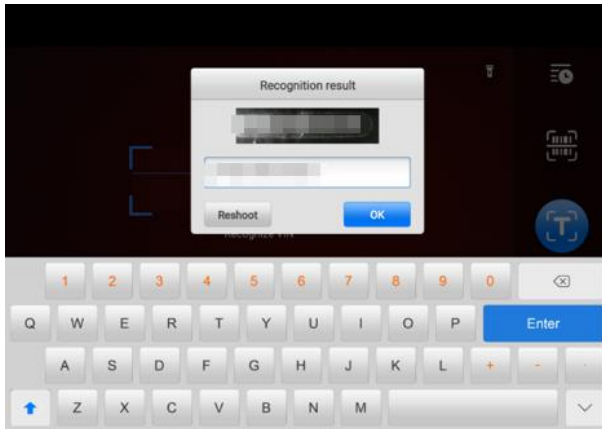

Figure 4-4 Scan VIN Code

If the VIN/License number cannot be scanned, please manually input the VIN/License number. Tap **OK** to continue. Confirm the VIN of the vehicle being tested to proceed.

4.3.1.4 Manual Vehicle Selection

When the vehicle's VIN is not automatically retrievable through the vehicle's ECU, or the specific VIN is unknown, you can select the vehicle manually.

Step-by-step Vehicle Selection

This mode of vehicle selection is menu-driven. Select a vehicle manufacturer on the Diagnostics Vehicle Menu screen and the Acquire VIN Information screen displays, then tap the **Manual Selection** button. Select the vehicle information like the Brand, Model, Capacity, Engine type, and Model year on the same screen. The **ESC** button at the lower-right corner of the screen will bring you back to the previous screen. Tap the **Reset** button to reselect the vehicle information if needed.

4.3.1.5 OBDII Direct Entry

Occasionally, the tablet may not be able to identify a vehicle. For these vehicles, the user may perform a generic OBDII or EOBD diagnostic. See [Generic OBDII Operations](#) for additional information.

4.4 Navigation

4.4.1 Diagnostics Screen Layout

After vehicle information is confirmed, tap **OK** to enter the main diagnostic program. This section describes common functions, including Auto Scan, Control Unit, Service, and Programming. The available functions may vary among different vehicles.

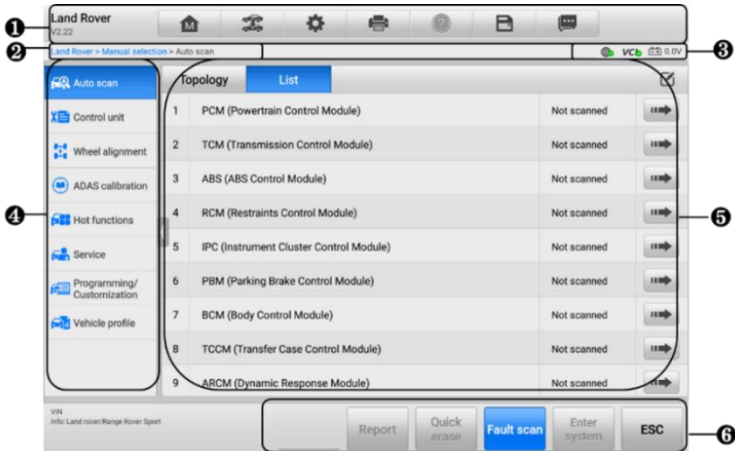









Figure 4-5 Diagnostics Main Menu Screen

1. Diagnostics Toolbar
2. Current Directory Path
3. Status Information Bar
4. Navigation Bar
5. Main Section
6. Function Buttons

4.4.1.1 Diagnostics Toolbar

The diagnostics toolbar contains buttons that allow you to print or save the displayed data and perform other operations. The table below provides a brief description for the operations of the diagnostics toolbar buttons:

Table 4-2 Diagnostics Toolbar Buttons

Button	Name	Description
	Home	Tap to return to MaxiSys Job Menu.
	Vehicle Swap	Exits the diagnostic session and returns to the vehicle menu screen to select another vehicle for testing.
	Settings	Opens the Settings screen. See Settings .
	Print	Saves and prints a copy of the displayed data. See Print Settings .
	Help	Provides instructions or tips for operations of various diagnostic functions.
	Save	Opens a submenu which provides options for data storage.
	Data Logging	Use this function when encountering an error while testing or diagnosing a vehicle. This function will record the communication data and ECU information of the test vehicle and send it to Autel's technical staff to review and provide solution. Go to the Support application to follow up the processing progress. See Data Manager .

➤ **To print data in Diagnostics**

1. Tap the **Diagnostics** application on the MaxiSys Job Menu. The **Print** button on the diagnostics toolbar is available throughout all Diagnostics operations.
2. Tap **Print** and a drop-down menu displays.
 - a) **Print This Page** — prints a screenshot copy of the current screen.
 - b) **Print All Data** — prints a PDF copy of all displayed data.
3. A temporary file will be created and sent via the computer to the printer.
4. When the file is sent, a confirmation message displays.

 **NOTE**

Make sure the tablet and the printer are connected either by Wi-Fi or LAN before printing. For more instructions on printing, see [Print Settings](#) for details.

➤ **To submit Data Logging reports in Diagnostics**

1. Tap the **Diagnostics** application on the MaxiSys Job Menu. The **Data Logging** button on the diagnostics toolbar is available throughout all Diagnostics operations.
2. Tap the **Data Logging** button to display the error options. Select a specific error, then tap **OK**, and a submission form will display to let you fill in the report information.
3. Tap the **Send** button in the upper-right corner of the screen to submit the report form via the Internet. A confirmation message displays when sent successfully.

4.4.1.2 *Current Directory Path*

The current directory path shows all directory names to access the current page.

4.4.1.3 *Status Information Bar*

The status information Bar at the top-right of the Main Section displays the following items:

1. **Network Status Icon** — indicates whether a network is connected.
2. **VCI Icon** — indicates the communication status between the tablet and the VCI device.
3. **Battery Icon** — indicates the battery status of the vehicle.

4.4.1.4 *Navigation Bar*

The navigation bar on the left side of the screen displays the main menu of the diagnostics functions. The main menu varies by the vehicle being tested. The common menu includes Auto Scan, Control Unit, Service, Hot Functions, Vehicle Profile, and Programming.

4.4.1.5 *Main Section*

The main section varies depending on the stage of operations which shows vehicle identification selections, the main menu, test data, messages, instructions, and other diagnostic information.

4.4.1.6 *Function Buttons*

The function buttons displayed at the bottom of the screen vary by operation. Function includes navigation, reporting, and code clearing. The functions of these buttons will be

described in the following sections when relevant.

 **NOTE**

The diagnostics toolbar (located on the top of the screen) will be active throughout the diagnostic session for tasks such as printing and saving the displayed data, obtaining help information, or performing data logging.

4.4.2 Screen Messages

Messages display when additional input is needed before proceeding. There are mainly three main types of on-screen messages: Confirmation, Warning, and Error.

4.4.2.1 Confirmation Messages

This type of messages usually displays as an “Information” screen, when you are about to perform an action that cannot be reversed or when an action has been initiated and your confirmation is needed to continue.

When a user-response is not required, the message displays briefly.

4.4.2.2 Warning Messages

This type of messages displays when completing the selected action may result in an irreversible change or loss of data. An example of this message is the “Erase Codes” message.

4.4.2.3 Error Messages

Error messages display when a systemic or procedural error has occurred. Possible errors include cable disconnection and communication interruption.

4.5 Diagnostics Menu

The Diagnostics application enables you to establish a data connection with the vehicle’s ECU through the VCI device for vehicle diagnosis and maintenance.

The Main Menu screen (see [Figure 4-5 Diagnostics Main Menu Screen](#)) navigates users to perform read codes, clear codes, or perform comprehensive automotive diagnostic functions, and so on. After the function is selected, the tablet will establish a communication with the vehicle through the VCI device, and enter the corresponding function menu or selection menu based on your selection.

4.6 Diagnostics Functions

Auto Scan

The Auto Scan function, which can be used to start auto scanning for all the available systems on the vehicle, will be listed on the navigation bar when accessing diagnostics function.

On the Auto Scan screen, there are two tabs: Topology Tab and List Tab.

A. Topology Tab Page

For a number of vehicle brands, including Volkswagen, Audi, BMW, Ford, Land Rover, Jaguar, Chrysler, Fiat, and Volvo, a topology map is available to display the relationship between vehicle systems. The Topology Tab page displays a system distribution diagram of the vehicle control modules.

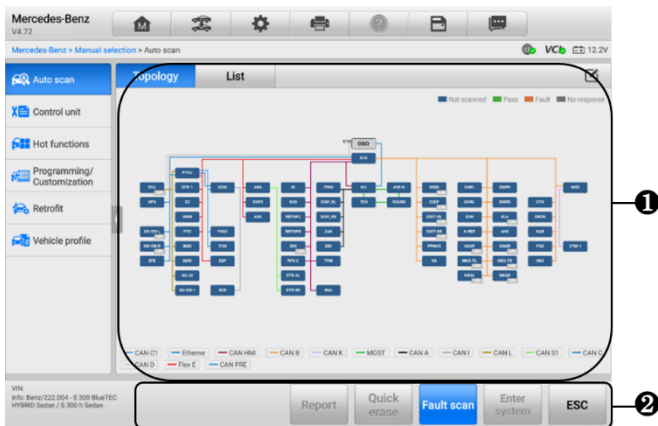

Figure 4-6 Topology Tab Page

B. List Tab Page

The List Tab page is available for most vehicles.

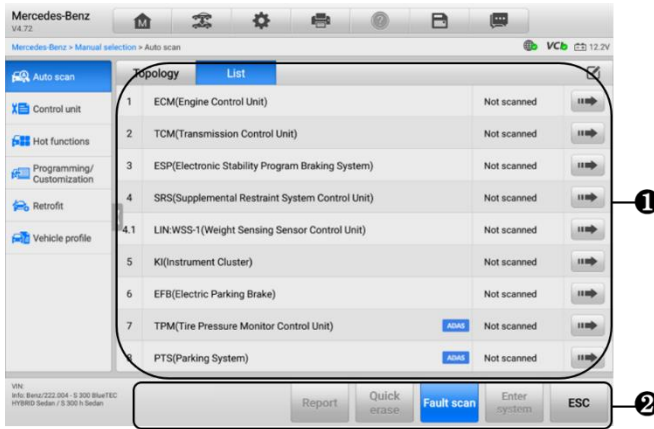

Figure 4-7 List Tab Page

1. Main Section

A. When displayed in a topology map

The ECU system of the tested vehicle is displayed in the form of a topology diagram, which describes the layout of the cables and systems of the vehicle control circuit and the path used for data transmission. Tap **Fault Scan** from the function buttons. The number of total faults will appear on the upper-right corner and the results will be displayed in different colors after scanning:

- Green: the system has detected no faults.
- Gray: the system has not received a response.
- Blue: the system has not been scanned.
- Orange: the system has detected faults. The number of faults appears on the upper-right corner of the system.

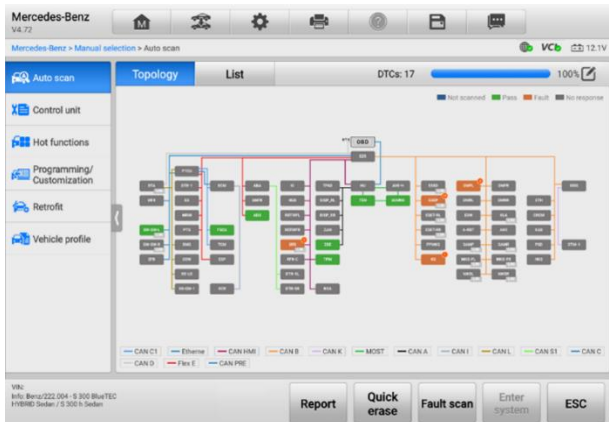



Figure 4-8 Scan Results in Topology Tab Page

B. When displayed in a list

- Column 1 — displays the system numbers
- Column 2 — displays the scanned systems
- Column 3 — displays the scan results
 - ✧ **Fault | #:** Indicates there is/are detected fault code(s) present; "#" indicates the quantity of detected faults.
 - ✧ **Pass | No Fault:** Indicates the system was scanned and no fault has been detected.
 - ✧ **Not Scanned:** Indicates the system has not been scanned.
 - ✧ **No Response:** Indicates the system has not received a response.
- Column 4 — tap the  button to enter a system for performing further diagnostics.

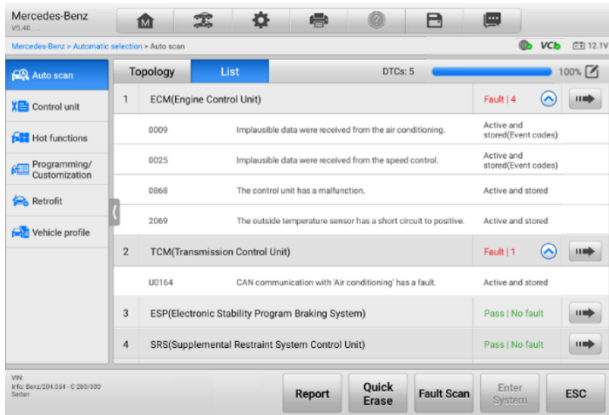

Figure 4-9 Scan Results in List Tab Page

2. Function Buttons

The table below provides a brief description of the function buttons:

Table 4-3 Function Buttons in Auto Scan Screen

Name	Description
Report	Displays the diagnostic data in report form.
Quick Erase	Erases all fault information after scanning.
Fault Scan	Scans vehicle system modules.
Pause	Pauses the scanning process.
Enter System	Enters the ECU system.
ESC	Returns to the previous screen or exits Diagnostics screen.

➤ To perform an Auto Scan function

Take topology as an example:

1. Tap the **Diagnostics** application button on the MaxiSys Job Menu. Choose the corresponding vehicle information and enter the Main Menu screen (see [Figure 4-5 Diagnostics Main Menu Screen](#)).
2. Select **Auto Scan** from the navigation bar.
3. The topology map displays in the main section. Tap the **Fault Scan** button at the bottom of the screen to scan the vehicle system modules.

Control Unit

The Control Unit function allows you to manually locate a required control system for testing through a series of choices. Simply follow the menu-driven procedures, and make proper selection each time; the program will guide you to the diagnostic function menu after a few choices you've made.

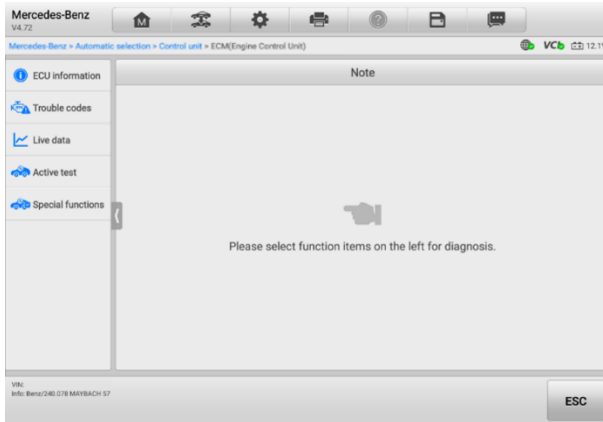

Figure 4-10 Control Unit Screen

Available functions may vary by vehicle. The function menu may include:

- **ECU Information** — displays detailed ECU information. Select to display information screen.
- **Trouble Codes** — contains Read Codes and Erase Codes. The former displays detailed DTC information retrieved from the vehicle control module. The latter facilitates you to erase DTCs and other data from the ECU.
- **Live Data** — retrieves and displays live data and parameters from the vehicle's ECU.
- **Active Test** — provides specific subsystem and component tests. This selection may display as *Actuators*, *Actuator Test*, or *Function Tests*. Available tests vary by vehicle.
- **Special Functions** — provides component adaptation or variant coding functions for custom configurations, and allows entry of adaptive values for certain components after repairs. Depending on the test vehicle, this selection may sometimes appear as Control Unit Adaptations, Variant Coding, Configuration, or something similar.

4.6.1 ECU Information

This function retrieves and displays the specific information for the tested control unit, including unit type, version numbers, and other information.

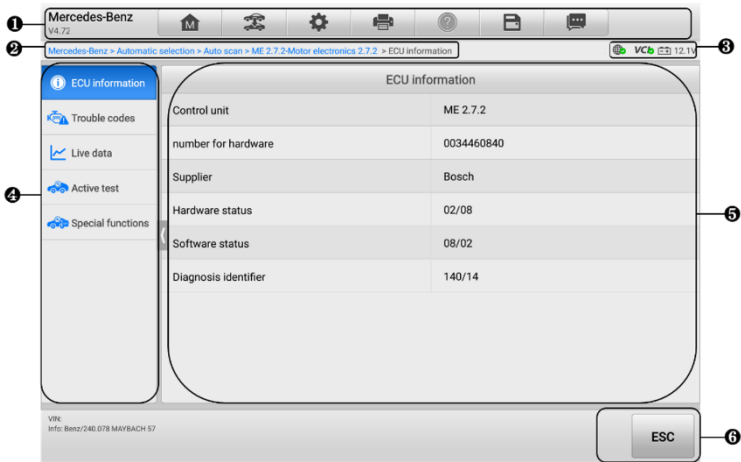

Figure 4-11 ECU Information Screen

1. Diagnostics Toolbar — see [Table 4-2 Diagnostics Toolbar Buttons](#) for detailed descriptions of the operations of each button.
2. Current Directory Path
3. Status Information Bar
4. Navigation Bar
5. Main Section — the left column displays the item names; the right column displays the specifications or descriptions.
6. Function Button — in this case, only an **ESC** button is available; tap it to exit after viewing.

4.6.2 Trouble Codes

The Freeze Frame, Read Codes, and Erase Codes function buttons are contained in the Trouble Codes screen. The Freeze Frame button will be activated if there are freeze frame data for viewing. Tap the **Erase Codes** button to erase DTCs and other data from the ECU, while tapping the **Read Codes** button to display the detailed DTC information retrieved from the vehicle control module. When tapping **Trouble Codes** from the navigation bar of the Control Unit screen, the tablet will automatically read the DTC

information in ECU.

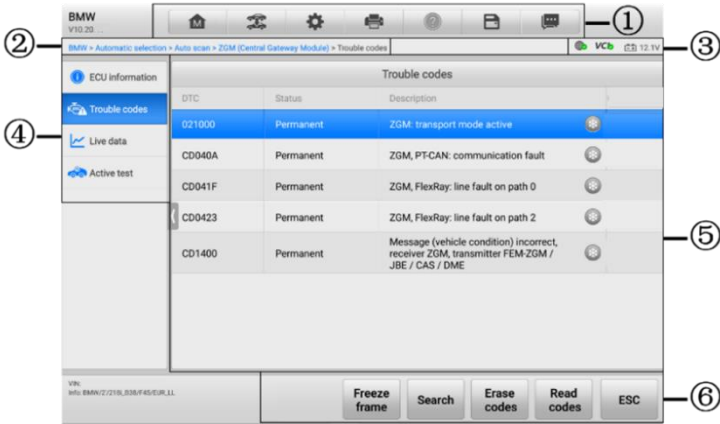

Figure 4-12 Trouble Codes Screen

1. Diagnostics Toolbar — see [Table 4-2 Diagnostics Toolbar Buttons](#) for detailed descriptions of the operations of each button.
2. Current Directory Path
3. Status Information Bar
4. Navigation Bar
5. Main Section
 - Column 1 — displays the retrieved codes from the vehicle
 - Column 2 — indicates the status of the retrieved codes
 - Column 3 — displays detailed descriptions for the retrieved codes
6. Function Buttons
 - **Freeze Frame** — a snowflake icon appears when freeze frame data is available for viewing. Tap the button to display data screen. The Freeze frame screen is similar to that of the Read codes screen and share similar operations.
 - **Search** — tap to search the selected DTC for additional information on the Internet.
 - **Erase Codes** — tap to erase codes from the ECU. It is recommended to read DTCs and make necessary repairs before erasing the codes.

After reading the retrieved codes from the vehicle and certain repairs have been made, you can erase the codes from the vehicle using this function. Before performing this function, make sure the vehicle's ignition key is in the ON (RUN)

position with the engine off.

➤ **To erase codes**

1. Tap **Erase Codes** from the function buttons.
 2. A warning message displays to inform you of data loss when this function is applied.
 - ✧ Tap **Yes** to continue. A confirming screen displays when the operation is successfully done.
 - ✧ Tap **No** to exit.
 3. Tap **ESC** on the confirming screen to exit Erase Codes screen.
 4. Check the Read Codes function again to ensure the operation is successful.
- **Read Codes** — retrieves and displays the DTCs from the vehicle control system. The Read Codes screen varies for each vehicle being tested.
 - **ESC** — tap it to return to the previous screen or exit the function.

4.6.3 Live Data

When this function is selected, the screen displays the data list for the selected module. The parameters display in the order that they are transmitted by the ECU, so expect variation among vehicles.

Gesture scrolling allows you to quickly move through the data list. Touch the screen and drag your finger up or down to reposition the parameters being displayed if the data occupies more than one screen. The figure below displays a typical Live Data screen:



Figure 4-13 Live Data Screen

1. Main Section

- Name Column — displays the parameter names.
 - ✧ Check Box — tap the check box to the left of a parameter to select the item. Tap the check box again to deselect it.
 - ✧ Drop-down Button — tap the drop-down button on the right side of a parameter to open a submenu that provides optional modes in which to display the data.
- Value Column — displays the values of the parameters.
- Range Column — displays the ranges of the parameters.
- Unit Column — displays the unit for the parameter values. When you need to change the unit mode, tap the **Settings** button on the diagnostics toolbar and select a required mode. See [Unit](#).

a) Display Mode

There are four types of display modes available for data viewing, allowing you to view various types of parameters in the mode best suited to represent the data.

Tap the drop-down button on the right side of a parameter to open a submenu. A total of 8 buttons will be displayed: the 4 buttons on the left represent different data display modes, plus one **Information** button (active when additional information is available), one **Add to Custom Group** button (tap to add the selected parameters to the custom group), one **Unit Change** button (for switching the unit of displayed data), and one **Trigger** button (for opening the Trigger Settings window).

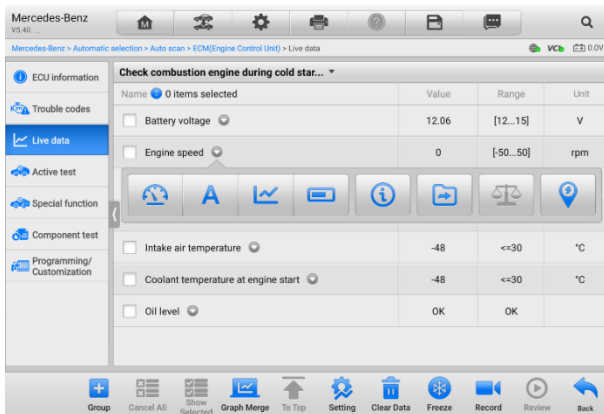

Figure 4-14 Display Mode Screen

Each parameter item displays the selected mode independently.

- ✧ **Analog Gauge Mode** — displays the parameters in gauge charts.
- ✧ **Text Mode** — the default mode that displays the parameters as a text list.

NOTE

Status parameters, such as a switch reading like ON, OFF, ACTIVE, and ABORT can only be displayed in Text Mode. Value parameters, such as a sensor reading, can be displayed in both text and graph modes.

- ✧ **Waveform Graph Mode** — displays the parameters in waveform graphs. In this mode, five control buttons will display on the right side of the parameter item, allowing you to manipulate the display status.

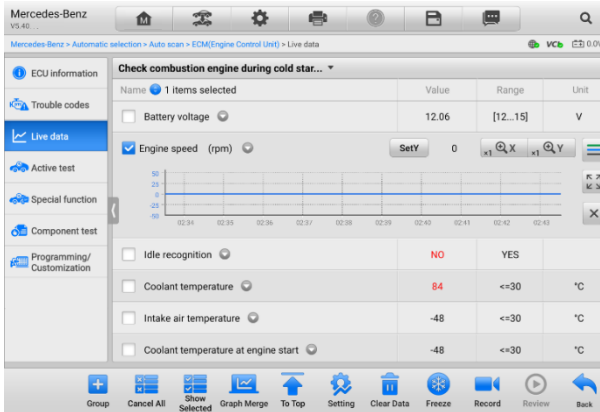

Figure 4-15 Waveform Graph Mode Screen

- 1) **Settings Button (SetY)** — sets the minimum and maximum value of the Y axis.
- 2) **Scale Button** — changes the scale values. There are four scales available for the X axis: x1, x2, x4 and x8. There are three scales available for the Y axis: x1, x2, and x4.
- 3) **Edit Button** — edits the waveform color and the line thickness.
- 4) **Zoom-in Button** — tap once to display the selected data graph in full screen.
- 5) **Exit Button** — tap to exit the waveform graph mode.

Full Screen Display — this option is only available in the waveform graph mode, and mostly used in Graph Merge status for data comparison. There are four control buttons available on the top-right side of the screen under this mode.

- **Scale Button** — tap to change the scale values below the waveform graph. There are four scales available for the X axis: x1, x2, x4 and x8. There are three scales available for the Y axis: x1, x2, and x4.

- **Edit Button** — tap to open an edit window, in which you can set the waveform color and the line thickness displayed for the selected parameter item.
 - **Zoom-out Button** — tap to exit full screen display.
 - **Exit Button** — tap to exit the waveform graph mode.
- **To edit the waveform color and line thickness**
1. Select parameter items to display in Waveform Graph mode.
 2. Tap the **Edit Button**, and an edit window displays.

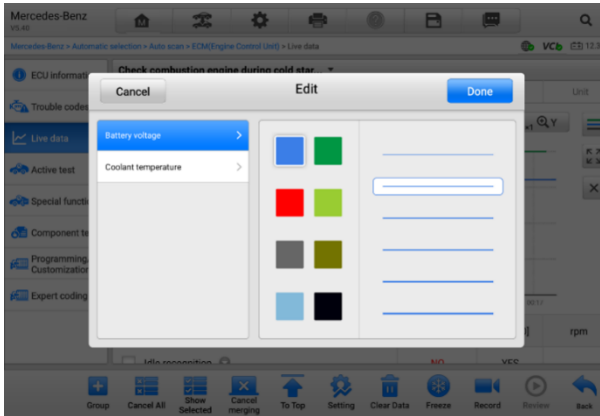

Figure 4-16 Waveform Edit Screen

3. The parameter item is selected automatically in the left column.
4. Select a color from the second column.
5. Select a line thickness from the right column.
6. Tap **Done** to save the setting and exit, or tap **Cancel** to exit without saving.

NOTE

In full screen display, please edit the waveform color and line thickness by tapping the **Edit** button on the top-right side of the screen.

✧ **Digital Gauge Mode** — displays the parameters in the form of a digital gauge graph.

b) **Trigger Settings**

On the trigger settings screen, you can set a standard range by filling in a minimum value and a maximum value. When exceeding this range, the trigger function will be executed and the device will automatically record and save the generated data. You can check the saved live data by tapping the **Review** button at the bottom of the screen.

Tap the drop-down button on the right side of the parameter name to open a submenu. The **Trigger** button is the last one in the submenu. Tap to display the trigger setting window.

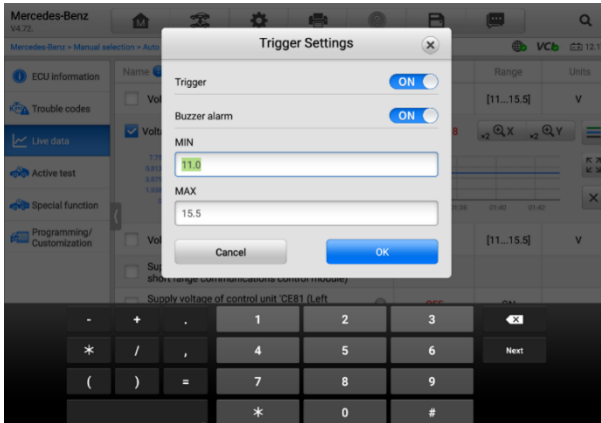

Figure 4-17 Trigger Settings Screen

Two buttons and two input boxes are available in the Trigger Settings window.

- a) **Trigger On** — switches the trigger on and off. The trigger is ON by default.
- b) **Buzzer Alarm** — switches the alarm on and off. The alarm function makes a beep sound as an alert when the data reading reaches the preset minimum or maximum point. The buzzer alarm will only sound at the first trigger.
- c) **MIN** — tap this input box to display a virtual keyboard to enter the required lower limit value.
- d) **MAX** — tap this input box to display a virtual keyboard to enter the required upper limit value.

➤ **To set a trigger**

- 1. Tap the drop-down button on the right side of the parameter name to open a submenu.
- 2. Tap the **Trigger** button on the right side of the submenu to open the trigger settings window.
- 3. Tap the **MIN** input box and enter the required minimum value.
- 4. Tap the **MAX** input box and enter the required maximum value.
- 5. Tap **OK** to save the setting and return to the Live Data screen; or tap **Cancel** to exit without saving.

When the trigger is successfully set, a trigger mark displays in front of the parameter name. The mark is gray when it is not triggered, and displays orange when triggered. Moreover, two horizontal lines display on each of the data graphs (when Waveform Graph Mode is applied) to indicate the alarm point. The limit lines are shown in different colors to differentiate them from the parameter waveforms.

2. Function Buttons

The operations of the available functional buttons on the Live Data screen are described below:

- ✧ **Group** — tap to set the selected parameters to the same group.
- ✧ **Cancel All** — tap this button to cancel all selected parameter items. Up to 50 parameters can be selected at one time.
- ✧ **Show Selected/Show All** — tap this button to switch between the two options; one displays the selected parameter items, and the other displays all the available items.
- ✧ **Graph Merge** — tap this button to merge selected data graphs (for Waveform Graph Mode only). This function is very useful when comparing different parameters.

NOTE

This mode supports Graph Merge of 2 to 5 parameters that can be represented digitally. Non-digital parameters are not supported.

➤ **To merge selected data graphs**

1. Select parameter items to be merged.
 2. Tap the **Graph Merge** button at the bottom of the Live Data screen.
 - a) This mode only supports parameters that can be represented digitally. If non-digital parameters are selected, a message will display advising the user that the selected parameters are not supported in this mode and to select 2 to 5 digital parameters. Tap the **Got It** button to return to the previous screen and select supported parameters.
 - b) If parameters are selected that are not supported in this mode, a message will display advising the user to select only parameters that are supported. A message will also display if more than 5 parameters have been selected. Please select 2 to 5 of the supported parameters and tap the **OK** button to merge.
 3. Tap the **Cancel Merging** button at the bottom of the Live Data screen to cancel merge.
- ✧ **To Top** — moves a selected data item to the top of the list.
 - ✧ **Setting** — tap this button to set recording duration.

➤ **To set live data record duration**

1. Tap the **Setting** button at the bottom of the Live Data screen.
2. Tap the > button to the right of **Recording time after trigger** bar and select a time length.
3. Tap **OK** to save the setting and return to the Live Data Setting screen; or tap the "X" button at the upper-right corner to exit without saving.
4. Tap **Done** at the upper-right corner of the Live Data Setting screen to confirm and save the setting, and return to the Live Data screen; or tap **Cancel** to exit without saving.

◇ **Clear Data** — tap this button to clear all cached live data.

◇ **Freeze** — displays the retrieved data in freeze mode.

- Previous Frame — moves to the previous frame of frozen data.
- Next Frame — moves to the next frame of frozen data.
- Play/Pause — tap to play/pause the frozen data.
- Resume — tap to exit the freeze data mode and return to normal data display.

◇ **Record** — starts recording the live data of the selected data items. Tap the **Record** button at the bottom of the Live Data screen. A message will display prompting user to select parameters to record. Tap the **Got It** button to confirm. Scroll down and select data to record. Tap the **Record** button to start recording. Tap the **Resume** button to stop recording. The recorded live data can be viewed in the **Review** section at the bottom of the Live Data screen. The recorded data can also be reviewed in the Data Manager application.

● Resume — Tap this button to stop data recording and to return to normal data display.

● Flag — this button displays when the Record function is applied. Tap this button to set flags to note points of interest when recording data. Notes can be added during playback in Review or Data Manager. Select the preset flag to open a popup window and display a virtual keyboard to input notes.

◇ **Review** — review the recorded data. Tap the **Review** button to display a recording list, and select one item to review.

 **NOTE**

Only the data recorded during the current operation can be reviewed on the Live Data screen. All the historical recorded data can be reviewed in "Review Data" in the Data Manager application.

- Previous Frame — switches to the previous frame of recorded data.
- Next Frame — switches to the next frame of recorded data.
- Play/Pause — tap to play/pause the recorded data.

- Show Selected — display the selected parameter items.
- Graph Merge — merges selected data graphs.
- Back — exits the review, and returns to the Live Data screen.

✧ **Back** — returns to the previous screen or exits the function.

4.6.4 Active Test

The Active Test function is used to access vehicle-specific subsystem and component tests. Available tests vary by vehicle.

During an active test, the tablet sends commands to the ECU to activate the actuators. This test determines the integrity of the system or part by reading ECU data, or by monitoring the operation of the actuators. Such tests may include switching a solenoid, relay, or switch, between two operating states.

Selecting Active Test displays a menu of test options. Available tests vary by vehicle.

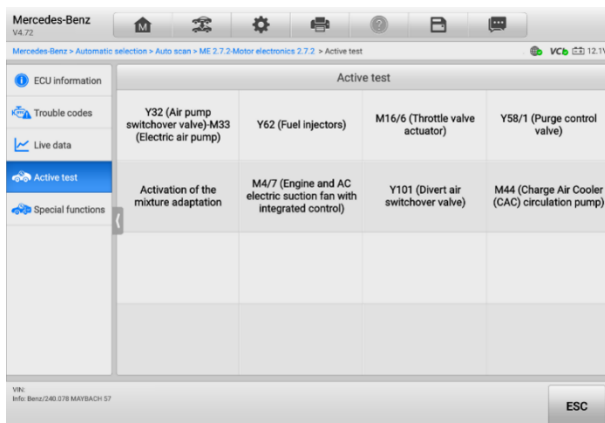

Figure 4-18 Active Test Screen

Select a test from menu options. Follow the instructions displayed on the screen to complete test. Procedures and instructions vary by vehicle.

The function buttons in the lower-right corner of the Active Test screen manipulate the test signals. The operational instructions are displayed in the main section of the test screen. Follow the on-screen instructions and make appropriate selections to complete the tests. Tap the **ESC** button to exit the test when finished.

4.6.5 Special Functions

Depending on the test vehicle, this selection may sometimes appear as Learning Process, Correction Programming, Emissions Inspection (Not valid for USA), OBd I/M Check (Not valid for USA), or something similar. You can select one to proceed according to your demands.

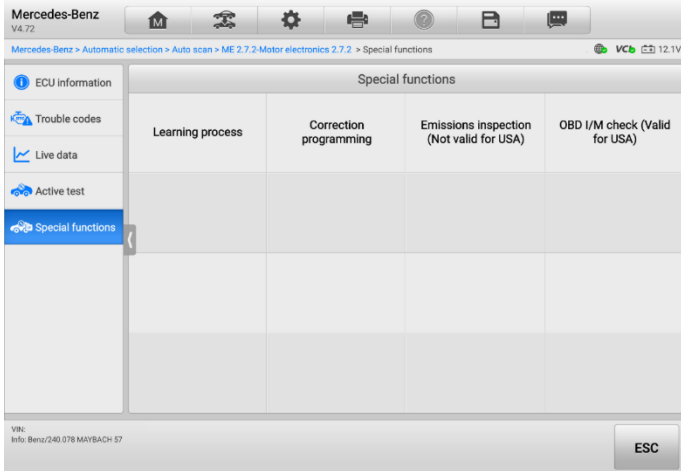



Figure 4-19 Special Functions Screen

4.7 Programming and Coding

Since the introduction of OBDII and leading up to modern hybrids and EVs, hardware and software technologies in cars have been advancing at an exponential rate. Updating software may be the only way to fix the following issues:

- Drivability
- Fuel Efficiency
- Power Loss
- Fault Codes
- Durability of Mechanical Parts

The Programming and Coding function is used to re-flash the vehicle control modules, which allows you to update the computer software of the vehicle to the latest version, as well as to reprogram adaptive data of certain components after making repairs or replacements.

 **NOTE**

The programming function applies only when the vehicle is connected with a VCI device, which serves as a PassThru interface to establish communication with and transfer data to the vehicle's ECU.

Available programming or coding operations vary by test vehicle. Only the available operations display in the tablet menu.

There are two general types of programming operations:

- A. Coding — also known as Teach-in Program, or Component Adaptation, is used to reprogram adaptive data for vehicle control modules after repairs or replacements of vehicle parts.
 - B. Reprogramming — downloads the latest version of software from the online server database through Internet access (this procedure is done automatically when the tablet is connected to the Internet, so there is no need to check for software updates yourself), and reprograms the newest version into the vehicle's ECU.
-

 **NOTE**

Ensure that the tablet is connected to a stable internet access before applying the ECU programming function, so that the tablet is able to obtain access to the vehicle manufacturer's server for update service.

Selecting the Programming opens a menu of operation options that vary by vehicle make and model. Selecting a menu option either displays a programming screen or opens another menu of additional choices. Follow the on-screen instructions to operate. How and what information is presented on the screen vary by the type of operation being performed.

4.7.1 Coding

The main section of the Coding screen displays a list of vehicle components and the coding information that mainly consists of two parts:

1. All available systems for coding are displayed on the left side, and the coding data or value on the right side.
2. The bottom of the main section displays the functional buttons that enable you to manipulate the operation.

Check the vehicle condition and the coding information carefully. Use the functional button to edit Codes for the corresponding components. Tap **Send** when you finish editing all items. When the operation is completed, an execution status message such as Completed, Finished or Successful, may display.

Tap the **ESC** button to exit the function.

4.7.2 Reprogramming

Before reprogramming begins:

- It is mandatory that the tablet is connected to a stable Wi-Fi network.
- The tablet must be connected to the VCI device via USB cable.
- The tablet battery must be fully charged during module programming. Connect the tablet to a charger if needed.
- Attach battery maintainer to vehicle battery to ensure a steady voltage is maintained throughout programming. Voltage requirements differ by vehicle manufacturer. Consult vehicle manufacturer recommendations prior to programming a module.
- Do not quit the application during a module reprogramming as the process may fail and may also result in permanent damage to the module.

Typical reprogramming operations require you to input and validate VIN number first. Tap the input box and enter the correct number. The programming interface then displays.

The main section of the reprogramming interface offers information of the hardware, the current software version and the newest software versions to be programmed into the control units.

A series of on-screen operational instructions will display to guide you through the programming procedure.

Carefully read the on-screen information and follow the instruction to execute the programming procedure.

4.7.3 Re-flash Errors

⚠ IMPORATANT

When reprogramming onboard, always make sure the vehicle battery is fully charged and in good working condition. During reprogramming, the operation may fail if voltage falls below the proper operation voltage. Sometimes a failed operation can be recovered, but the failed reprogramming can also ruin the control module. We recommend connecting an external battery maintainer to the vehicle to ensure a steady voltage is maintained throughout programming. The required voltage differs by vehicle manufacturer. Consult vehicle manufacturer for correct voltage to be maintained.

Occasionally a flash update procedure may not complete properly. Common causes of flash errors include poor cable connections between the tablet, VCI, and vehicle, the vehicle ignition being switched off before the flash procedure is complete, or low vehicle

battery voltage.

If the process quits, recheck all the cable connections to assure good communications and initialize the flash procedure. The programming procedure will automatically repeat if the previous operation does not succeed.

4.8 Generic OBDII Operations

The OBDII/EOBD vehicle diagnosis option offers a quick way to check for DTCs, isolate the cause of an illuminated malfunction indicator lamp (MIL), check monitor status prior to emissions certification testing, and perform other emissions-related services. The OBDII direct access option is also used for testing OBDII/EOBD compliant vehicles that are not included in the database. Diagnostics Toolbar Buttons at the top of the screen are available for specific vehicle diagnostics. See [Table 4-2 Diagnostics Toolbar Buttons](#) for details.

4.8.1 General Procedure

➤ **To access the OBDII/EOBD diagnostics functions**

1. Tap the **Diagnostics** button from the MaxiSys Job Menu. The Vehicle Menu displays.
2. Tap the **EOBD** button. There are two options to establish communication with the vehicle.
 - Auto Scan — select it to establish communication using each protocol in order to determine which one the vehicle is using.
 - Protocol — select it to open a submenu of various protocols. A communication protocol is a standardized way of data communication between an ECM and a diagnostic tool. Global OBD may use several different communication protocols.
3. Select a specific protocol if the **Protocol** option is selected. Wait for the OBDII/EOBD Diagnostic Menu to appear.

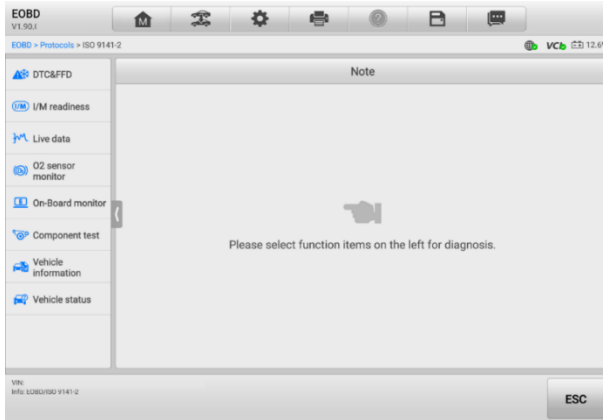

Figure 4-20 OBDII Diagnostic Menu

4. Select a function option to continue.
 - DTC & FFD
 - I/M Readiness
 - Live Data
 - O2 Sensor Monitor
 - On-Board Monitor
 - Component Test
 - Vehicle Information
 - Vehicle Status

NOTE

The supported functions may vary by vehicle.

4.8.2 Function Descriptions

This section describes the various functions of each diagnostic option:

4.8.2.1 DTC & FFD

When this function is selected, the screen displays a list of Stored Codes and Pending Codes. When the Freeze Frame data of certain DTCs are available for viewing, a snowflake button will display on the right side of the DTC item. The Erase Codes and Read codes functions can be applied by tapping the Function Buttons at the bottom of the screen.

- **Current Codes**

Current codes are emission-related DTCs from the ECM of the vehicle. OBD II/EOBD Codes have a priority according to their emission severity, with higher-priority codes overwriting lower-priority ones. The priority of the code determines the illumination of the Malfunction Indicator Lamp (MIL) and the codes erase procedure. Manufacturers rank codes differently, so DTCs may vary by vehicle.

- **Pending Codes**

These are codes whose storing conditions have been met during the last drive cycle, but need to be met on two or more consecutive drive cycles before the DTC stored. The purpose of displaying pending codes is to assist the service technician after a vehicle repair when diagnostic information is cleared, by reporting test results after a single driving cycle.

- a) If a test fails during the driving cycle, the DTC associated is reported. If the pending fault does not occur again within 40 to 80 warm-up cycles, the fault is automatically cleared from memory.
- b) Test results reported do not necessarily indicate a faulty component or system. If test results indicate another failure after additional driving, a DTC is stored to indicate a faulty component or system.

- **Freeze Frame**

In most cases the stored frame is the last DTC reported. Certain DTCs, those that have a greater impact on vehicle emission, have a higher priority. In these cases, DTC of the highest priority is the one for which the freeze frame records are retained. Freeze frame data includes a "snapshot" of critical parameter values at the time the DTC is stored.

- **Erase Codes**

This option is used to clear all emission-related diagnostic data including DTCs, freeze frame data and specific manufacturer-enhanced data from the vehicle ECM. This option resets the I/M Readiness Monitor Status for all vehicle monitors to Not Ready or Not Complete status.

A confirmation screen displays when the clear codes option is selected to prevent accidental loss of data. Select **Yes** on the confirmation screen to continue, or select **No** to exit.

4.8.2.2 *I/M Readiness*

This function is used to check the readiness of the monitoring system. It is an excellent function to use prior to having a vehicle inspected for state emissions compliance.

Selecting I/M Readiness opens a submenu with two choices:

- Since DTCs Cleared — displays the status of monitors since the last time the DTCs are erased.
- This Driving Cycle — displays the status of monitors since the beginning of the current drive cycle.

4.8.2.3 *Live Data*

This function enables the display of real-time PID data from the ECU. Displayed data includes analog and digital input and output, and system status information broadcast in the vehicle data stream.

Live data can be displayed in various modes, see [Live Data](#) for detailed information.

4.8.2.4 *O2 Sensor Monitor*

This function allows retrieval and review of recent O2 sensor monitor test results stored on the vehicle's on-board computer.

The O2 Sensor Monitor test function is not supported by vehicles that communicate using a controller area network (CAN). For O2 Sensor Monitor tests results of CAN-equipped vehicles, refer to [On-Board Monitor](#).

4.8.2.5 *On-Board Monitor*

This function allows you to view the results of On-Board Monitor tests. The tests are useful after the service when a vehicle's control module memory is already erased.

4.8.2.6 *Component Test*

This function enables dual-directional control of the ECM so that the diagnostic tool can transmit control commands to operate the vehicle systems. This function is useful in determining how well the ECM responds to a command.

4.8.2.7 *Vehicle Information*

This function enables the display of the vehicle identification number (VIN), calibration identification number, calibration verification number (CVN), and other information of the test vehicle.

4.8.2.8 *Vehicle Status*

This function checks the current condition of the vehicle, such as the communication protocols of OBDII modules, number of fault codes, and status of the Malfunction Indicator Light (MIL).

4.9 Diagnostic Report

4.9.1 Pre-Scan and Post-Scan Functions

After performing pre-scan and post-scan functions by entering the same maintenance order number, tap **Data Manager > Vehicle History** to select the historical test record named with the maintenance order number. Both the pre-scan results and post-scan results will be displayed in the same historical test record, which can be generated as a PDF report for easily comparing the changes between pre-scan and post-scan.

- **Pre-Scan Function**

Select and tap a vehicle button from the Vehicle Menu screen. Enter the maintenance order number in the pop-up box to scan and detect the whole vehicle. You can also add pictures to record the current condition of the vehicle. Once the pre-scan is completed, you are not allowed to perform pre-scan again, and the scan result cannot be modified.

- **Post-Scan Function**

After the pre-scan is complete, exit the current test vehicle and tap the vehicle button from the Vehicle Menu screen to reconnect again. Enter the same maintenance order number in the pop-up box. The screen for post-scan will display. The post-scan record will be generated when the scan is completed. The pre-scan results and post-scan results will be displayed in the same historical test record.

 **NOTE**

The post-scan function can be performed repeatedly. After exiting the vehicle, you only need to tap the vehicle button from the Vehicle Menu screen to reconnect again, then enter the same maintenance order number in the pop-up box and follow the steps to rescan. The last one is the final post-scan result.

4.9.2 Diagnostics Report Saving, Viewing, and Sharing

The diagnostic report can be reviewed, saved, and shared with others through many ways.

4.9.2.1 Diagnostics Report Saving

- Via the **History** function
 - 1) Tap **Diagnostics** on the MaxiSys Job Menu, and select **History** on the top toolbar.

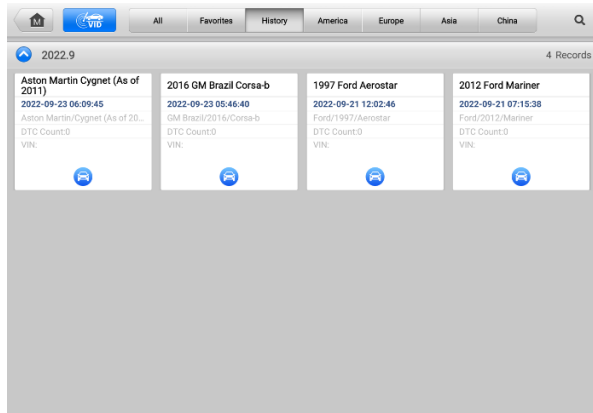

Figure 4-21 History Screen

- 2) Select a history record, and tap the **...** button on the upper-right corner.

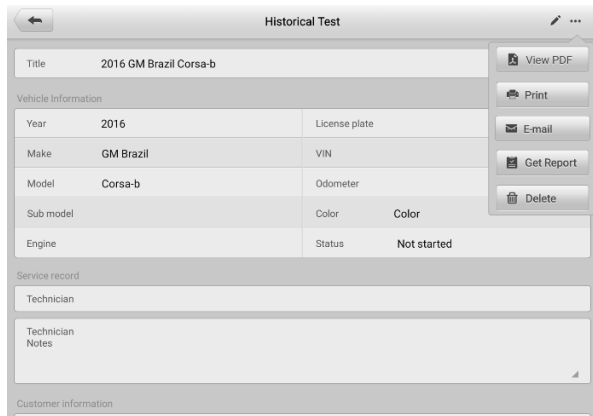

Figure 4-22 Historical Test Screen

- 3) Tap **Get Report**. Enter the license plate and current mileage. Tap **Save**.
- Via the **Auto Scan** function
 - 1) Enter the Auto Scan page and tap **Fault Scan** from the function buttons at the bottom of the screen.

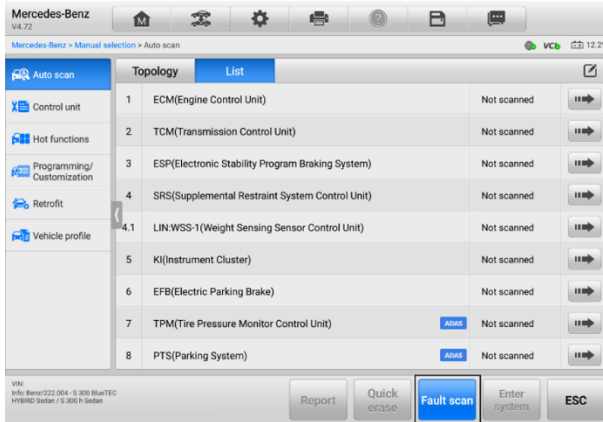

Figure 4-23 Auto Scan Screen 1

- 2) When the system scan is completed, tap **Report** from the function buttons at the bottom of the screen.

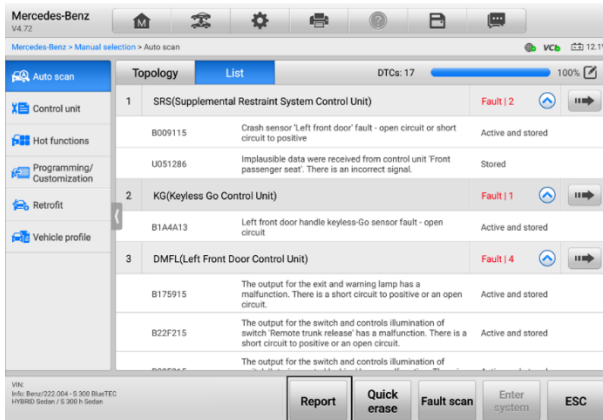





Figure 4-24 Auto Scan Screen 2

- Via the functions on the diagnostics toolbar

The diagnostic report can also be viewed from diagnostics functions screen including Auto scan and Trouble codes. There are two ways to view the saved reports:

- ✧ Tap the  button in the diagnostics toolbar and select **Save as PDF**. Enter the license number and tap **Save**. Tap the  button on the upper-right of the screen to view the report.
- ✧ Tap the  button in the diagnostics toolbar and select **Report to Cloud**. Enter the license number and current mileage. Tap **Save > View Report** and then select a saved report to view.

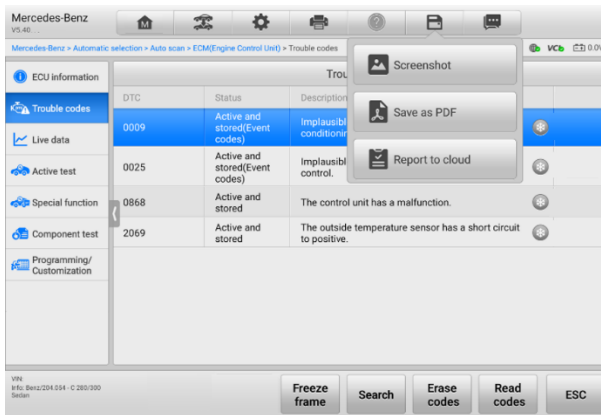

Figure 4-25 Trouble Codes Screen

4.9.2.2 Diagnostics Report Viewing

All the saved reports can be viewed in the Data Manger application.

- ✧ Tap **Data Manager > Vehicle History**. Select a specific vehicle history record and then tap **View PDF** in the upper-right corner to view the report.
- ✧ Once you save the reports by tapping the **Save as PDF** button, tap **Data Manager > PDF** to view these reports.
- ✧ Once you save the reports by tapping the **Get Report** or **Report to Cloud** button, tap **Data Manager > Cloud Report** to view these reports.

4.9.2.3 Diagnostics Report Cloud Sharing

- 1) Tap **Data Manager > Cloud Report** to enter the Report List screen.

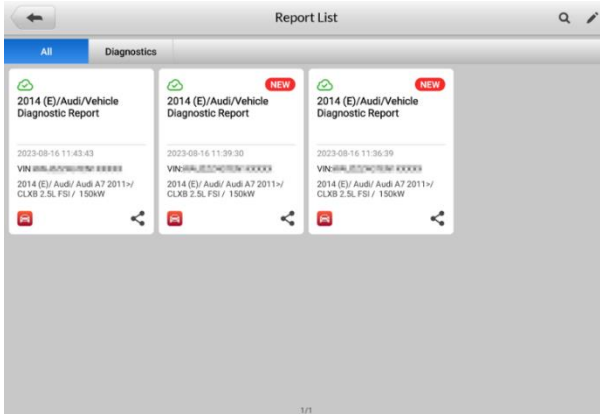





Figure 4-26 Report List

NOTE

Note that if the report displays  , it means the report has been uploaded to the cloud successfully, and you can share the report with others; if the report displays  , it means the report has failed to upload to the cloud, but will try to automatically upload to the cloud when entering the Report again.

- 2) Tap the  on the lower-right corner of the report.
- 3) There are three ways for report cloud sharing: scan the QR code, send by email, send by SMS (via phone number).

4.10 Exit Diagnostics

The Diagnostics application operates while communication with the vehicle is still active. It is important to properly exit from the diagnostics operation screen to stop all communications with the vehicle before closing the Diagnostics application.

NOTE

Damage to the vehicle electronic control module (ECM) may occur if communication is disrupted. Ensure all forms of communication link such as data cable, USB cable, and wireless or wired network, are properly connected throughout the test. Exit all screens before disconnecting the test cable and power supply.

➤ **To exit the Diagnostics application**

1. On an active diagnostics screen:
 1. Tap the **Back** or **ESC** button to exit a diagnostic session step by step.
 2. Or tap the **Vehicle Swap** button in the Diagnostics Toolbar to return to the Vehicle Menu screen.
2. On the vehicle menu screen:
 - 1) Tap the **Home** button on the Top Toolbar.
 - 2) Or tap the **Back** button on the Navigation Bar at the bottom of the screen.
 - 3) Or tap the **Home** button on the Diagnostics Toolbar to exit the application directly and return to the MaxiSys Job Menu.

 **NOTE**

After exiting the Diagnostics application, the tablet is no longer communicating with the vehicle and it is safe to open other MaxiSys applications.

5 Wheel Alignment

The vehicle's four wheels, steering mechanism, and front and rear axles should have a certain relative position. This relative position is a standard value established by the manufacturer. However, the relative position may change after reinstalling the related components or driving the vehicle for a period of time, the procedure of adjusting and restoring to this position is called wheel alignment. After wheel alignment, the vehicle can be driven in a straight line as much as possible, the ease of steering control will be increased, and the additional tire wear and power consumption will be decreased. Therefore, it is necessary to perform Wheel Alignment function before driving.

5.1 Preparatory Work

Before performing Wheel Alignment function, please check and set:

1. The tablet is connected with the IA900WA Wi-Fi and Internet accessible network. See [Calibration Frame Connection](#) and [Network Configuration](#) for details.
2. Depending on the tools and experience you have, select clamp type in the Settings application first. Here we select **Rim Clamp** (the default setting) for illustration.
3. A proper communication between the vehicle and tablet is established. See [Establish Vehicle Communication and Selection](#) for details.
4. The ignition is turned off, and the IA900WA is connected to the charger to avoid the battery power loss, as the whole wheel alignment procedure may take a long time.

5.2 Precautions in Use

1. When the vehicle is on the lift, make sure the front wheel is in the center of the turnplate.
2. After the vehicle is driven on the lift, wheel chocks should be placed in front and rear of the two rear wheels to prevent the vehicle from rolling away.
3. Be careful when lifting the vehicle. Follow the safe operating procedures to lift the vehicle.
4. When the vehicle is lifted to the required height, the vehicle can only be started after the insurance is in effect and safety is ensured.
5. Operating the lift is strictly forbidden when someone is working.
6. Make sure the camera lens and target are clean.

7. When wheel clamps are required, ensure the pawls on each wheel clamp are adjusted to the same length.
8. Strictly follow the software procedures and prompts to operate.

5.3 Vehicle Communication and Selection

There are three ways to access the Wheel Alignment function:

1. Through the Wheel Alignment Application: two options are available.
 - Wheel alignment: when you select **Wheel Alignment**, the tablet will guide you to perform Wheel Alignment function only.
 - Advance Wheel Alignment: when you select **Advanced Wheel Alignment**, the tablet will guide you to perform the complete Wheel Alignment function including wheel alignment, steering angle reset, and ADAS calibration, which is the same as the wheel alignment function in the Diagnostics application.
2. Through the Diagnostics Application: for vehicles that support Wheel Alignment function, the Wheel Alignment function will be listed on the Navigation Bar in the Diagnostics Main Menu screen.

5.3.1 Through the Wheel Alignment Application

Tap **Wheel Alignment** or **Advanced Wheel Alignment** based on your needs to proceed.

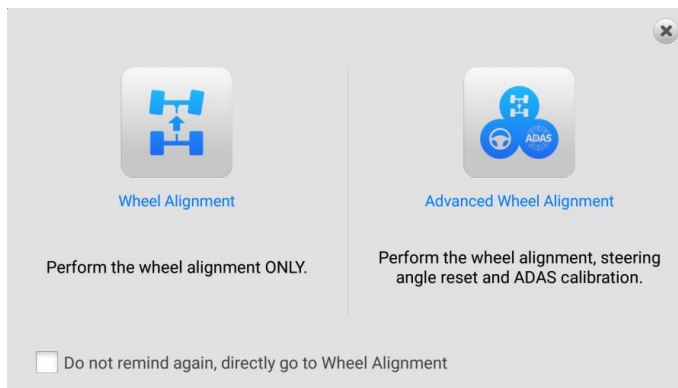

Figure 5-1 Wheel Alignment Function Entrance Screen

5.3.1.1 Wheel Alignment

1. If you select **Wheel Alignment**, the screen is as follows.



Figure 5-2 Vehicle Selection Screen (Wheel Alignment)

2. Select and tap on the manufacturer of your vehicle from the Vehicle Manufacturer buttons. Then follow the on-screen instructions to select the configuration information of your vehicle one by one.

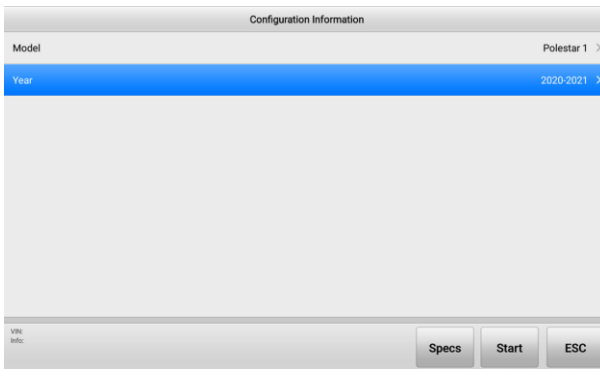

Figure 5-3 Select Configuration Screen 1 (Wheel Alignment)

3. Once the configuration information is completed, tap the **Specs** button to check and edit the alignment specifications. See [Wheel Alignment Parameters](#) for details.

- If the parameters related to wheel alignment are correct, tap **Start** and follow the on-screen instructions step by step to continue, and finally enter the whole Wheel Alignment Procedures screen.

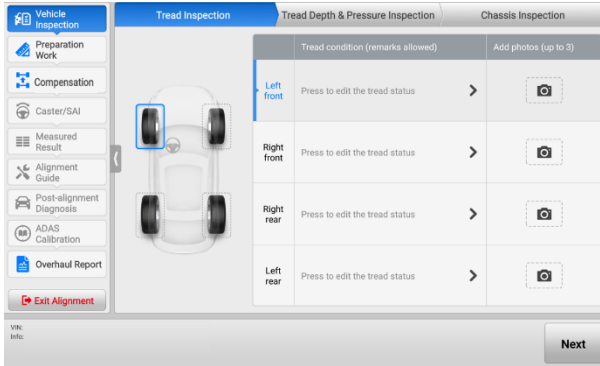

Figure 5-4 Complete Wheel Alignment Procedures Screen

5.3.1.2 Wheel Alignment Parameters

After selecting the vehicle configuration information, the **Specs** button will be available in the Function Buttons. This button is used to customize the wheel alignment parameters. It is suitable for vehicles which the parameters are different from those in the original factory after chassis modification.

- Tap the **Specs** button. You can check all the wheel alignment parameters.

Front specifications		Rear specifications	
Front	Spec.	Measurement (Min.)	Measurement (Max.)
Total toe	0°07'	-0°05'	0°19'
Left toe	0°04'	-0°02'	0°10'
Right toe	0°04'	-0°02'	0°10'
Left camber	1°05'	0°23'	1°47'
Right camber	1°05'	0°23'	1°47'
Cross camber	0°00'	-0°42'	0°42'
Left caster	5°43'	5°07'	6°19'
Right caster	5°43'	5°07'	6°19'

path: Polestar 1 / 2020-2021 / Default specifications

VIN: info:

Buttons: Edit, Unit Setting, Start, ESC

Figure 5-5 Alignment Specifications Screen

- If there are any parameters need to be edited, tap the **Edit** button from the Function Buttons.

Front specifications		Rear specifications			
Front	Spec.	Measurement (-Tol.)	Measurement (+Tol.)	Adjustment (-Tol.)	Adjustment (+Tol.)
Total toe	0°07'	0°12'	0°12'	--	--
Total toe (raised)	--	--	--	--	--
Left toe	0°04'	0°06'	0°06'	--	--
Right toe	0°04'	0°06'	0°06'	--	--
Cross toe	--	--	--	--	--
Left camber	1°05'	0°42'	0°42'	--	--
Right camber	1°05'	0°42'	0°42'	--	--
Cross camber	0°00'	0°42'	0°42'	--	--

path: Polestar 1 / 2020-2021 / Default specifications

VIN info: Save As Unit Setting Start ESC

Figure 5-6 Edit Alignment Specifications Screen

- Tap and delete the parameters that need to be edited and enter the correct parameters. Then tap **Save** or **Save As** to enter the Save Specifications screen.

Save Specifications

Title

Annotation

VIN info: OK ESC

Figure 5-7 Save Specifications Screen 1

- Enter the vehicle model and annotation for the specifications, so that you can better distinguish and find them.
- After entering the vehicle model and annotation for the parameters, tap **OK** to save the parameters.

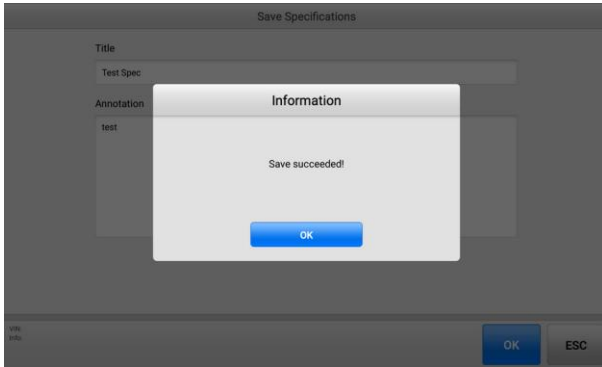

Figure 5-8 Save Specifications Screen 2

- After editing and saving all parameters, the tablet will return to the Wheel Alignment Parameters screen. Tap the **ESC** button, then the saved parameters for the vehicle will be selected on the Configuration Information screen.

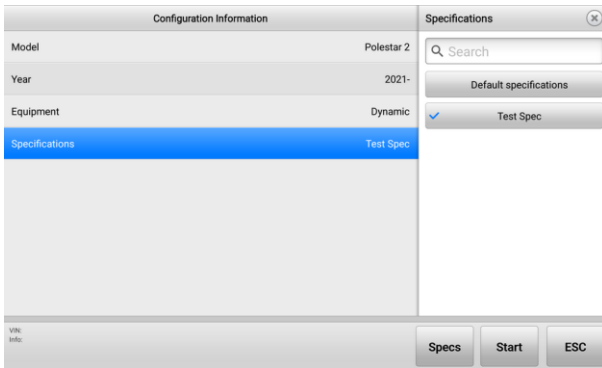

Figure 5-9 Select Configuration Screen 2 (Wheel Alignment)

- Tap **Start** and follow the on-screen instructions step by step to continue, and finally enter the whole Wheel Alignment Procedures screen. See [Figure 5-4 Complete Wheel Alignment Procedures Screen](#).

5.3.1.3 Advance Wheel Alignment

1. If you select **Advanced Wheel Alignment**, the screen is as follows.

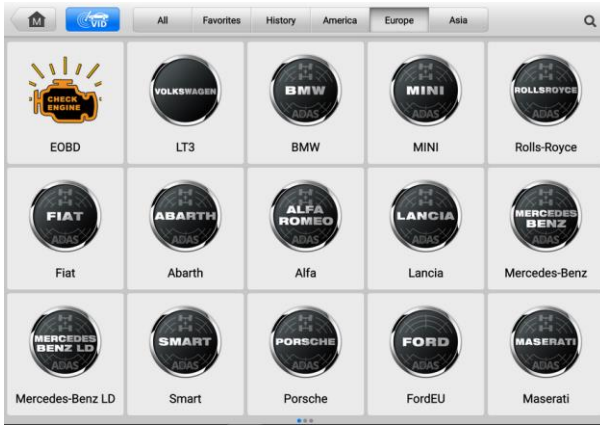

Figure 5-10 Vehicle Selection Screen (Advanced Wheel Alignment)

2. Follow the steps in [Vehicle Identification](#) to enter the Diagnostics Main Menu screen, which is consistent with the screen on the Diagnostics application.
3. Select **Wheel Alignment** on the Navigation Bar on the left of the screen, then select the situations needed for performing wheel alignment on the right of the screen.

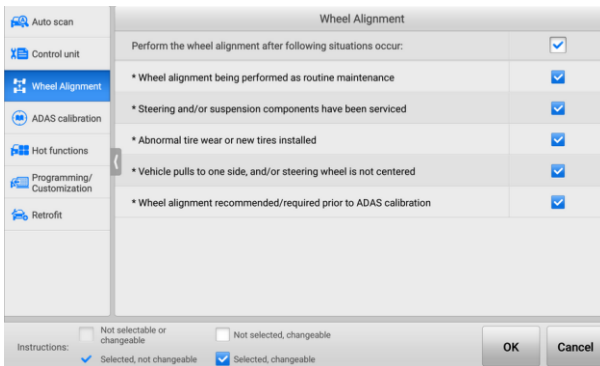

Figure 5-11 Acquire VIN Screen (Advanced Wheel Alignment)

4. Tap **OK** after the situations are selected to complete the configuration information.

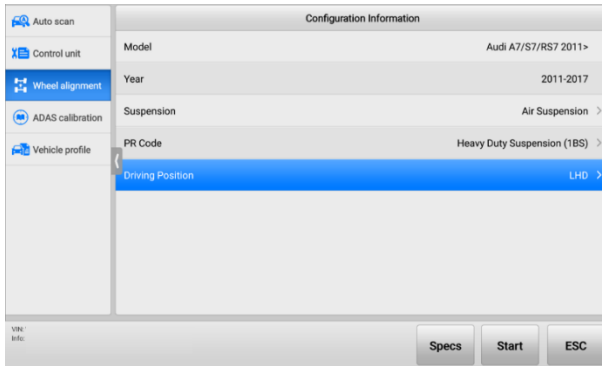

Figure 5-12 Wheel Alignment Screen (Advanced Wheel Alignment)

5. Once the configuration information is completed, tap the **Specs** button to check and edit the wheel alignment parameters. See [Wheel Alignment Parameters](#) for details.
6. Tap **Start** after checking and editing the wheel alignment parameters. Then follow the on-screen instructions step by step to continue, and finally enter the whole Wheel Alignment Procedures screen.

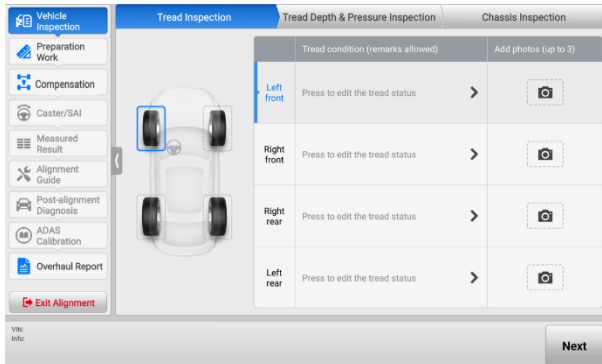

Figure 5-13 Complete Configuration Information (Advanced Wheel Alignment)

5.3.2 Through the Diagnostics Application

The Wheel Alignment function accessed in the Diagnostics application is the same as accessing the Wheel Alignment function by selecting **Advanced Wheel Alignment** in the Wheel Alignment application.

1. Before entering the Wheel Alignment function through the Diagnostics application, a proper communication between the vehicle and tablet should be established. Refer to [Establish Vehicle Communication and Selection](#) for details.
2. Then follow the on-screen instructions to operate step by step, and finally enter the Diagnostics Main Menu screen. If the vehicle supports Wheel Alignment function, this function will be listed on the Navigation Bar on the left of the screen.

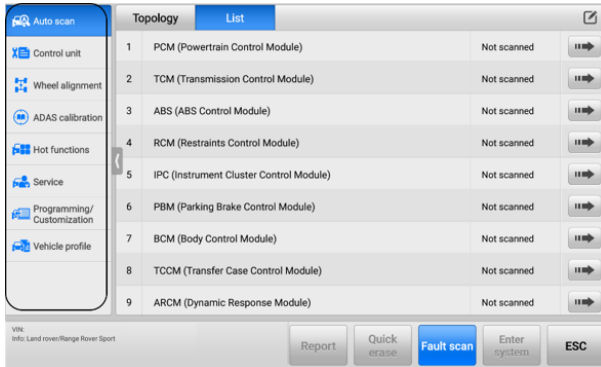

Figure 5-14 Diagnostics Navigation Bar

3. Select **Wheel Alignment** from the Navigation Bar to continue (see [Figure 5-12 Wheel Alignment Screen \(Advanced Wheel Alignment\)](#)). The following steps are the same as described in the Advanced Wheel Alignment. You can follow the on-screen instructions to operate step by step, and finally enter the whole Wheel Alignment Procedures screen (see [Figure 5-4 Complete Wheel Alignment Procedures Screen](#)).

5.4 Wheel Alignment Procedures

5.4.1 Vehicle Inspection

1. Before performing wheel alignment, the tire tread condition and tread depth should be checked, as the tire abnormality will affect the wheel alignment test results.
2. Before performing wheel alignment, the tire pressure also needs to be checked and adjusted to the standard value for the vehicle. This is because the deviation of the pressure will affect the wheel alignment test results.
3. Chassis components can be inspected by fault type or vulnerability.

! IMPORTANT

Before performing the wheel alignment procedures, check the settings from **Settings > ADAS & Aligner Settings > Wheel Alignment Software Settings**. You can change the settings according to your needs and actual situation. The whole wheel alignment procedures in this manual are based on the default settings in **ADAS & Aligner Settings**.

5.4.1.1 Tread Inspection

a) Tread condition (remark allowed) column

According to the condition of the four tires, tap the tread status description area to add or edit each tread status of the vehicle. The tread condition includes normal, outside wear, inside wear, bilateral wear, feather edge, spot wear, aging, flat crushing, excessive wear, bulge, wear/puncture, different tread/brand on one axle, tire valve aging, rim damage, and unauthorized tire. Notes can be added when the tire is abnormal. Once the tread conditions of all tires are selected, tap **OK**. Then check the color of the four tires on the screen, if the color of the tire is red or yellow, replace or repair the tire according to the specific situation before tapping **Next**.

b) Add photos column

In order to judge and view the tread status better, you can tap the camera icon in the add photos column to add photos. Up to three photos of each tread can be added.

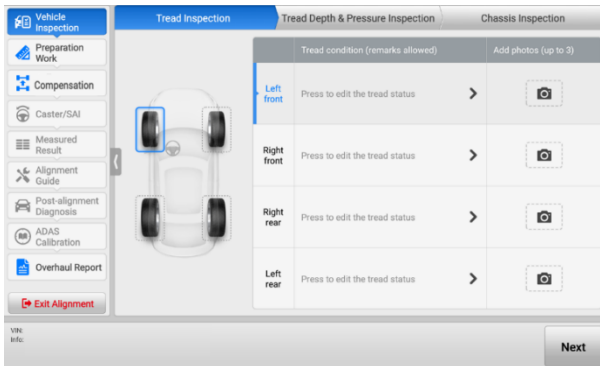

Figure 5-15 Tread Inspection Screen

5.4.1.2 Tread Depth & Pressure Inspection

When performing vehicle check, it is also necessary to check the tread depth & pressure.



Figure 5-16 Tread Depth & Pressure Inspection Screen 1

1. Tread Pressure Inspection

- a) Enter the standard tread pressure in the corresponding input box. The standard tire pressure is found on the tire and loading information placard, normally located on the B-pillar.

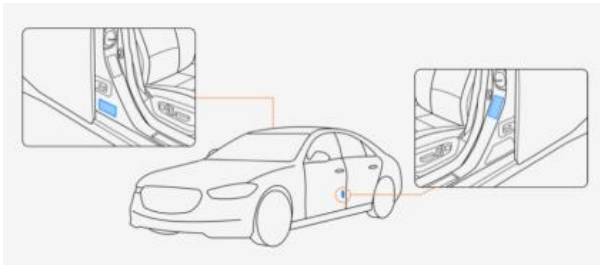

Figure 5-17 Standard Tire Pressure Value Location

2. Tread Depth Inspection

- a) There are two modes for measuring tread depth: All Tread Check and Single Check. All Tread Check, measuring the tread depth at three positions including outside, middle and inside of the tire (nearest the vehicle body); while the Single Check is only to measure the tread depth at one of the following positions: outside, middle, or inside of the tire (nearest the vehicle body). You can tap **All Tread Check** or **Single Check** to change the check mode.

- b) To measure the tread depth, Autel MaxiTPMS TBE series device (hereinafter referred as to TBE device) or other tread depth measurement tools is required. If you use TBE device to measure the tread depth, the values will be automatically displayed in the corresponding input box. If you use other tools to measure the tread depth, you need to manually enter the values in the corresponding input box.

NOTE

After entering all the tread depth values and tread pressure values, check the color of the four tires on the screen, then replace or repair the tire according to the specific situation.



Figure 5-18 Tread Depth & Pressure Inspection Screen 2

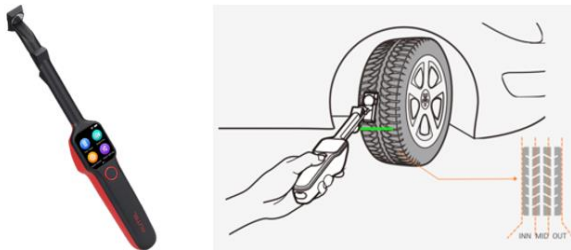

Figure 5-19 MaxiTPMS TBE Device (not included) and Use Diagram

➤ **To connect with MaxiTPMS TBE device**

1. Tap the **Settings** application from the MaxiSys Job Menu.
2. Tap the **ADAS & Aligner Settings** option on the left column.
3. Tap **Common Settings** from the right of the screen.
4. Select **Connect Tread Measuring Tool**.
5. Switch the button to **ON** to search available device(s).
6. Follow the on-screen guides to connect the TBE device and the tablet to the same Wi-Fi.

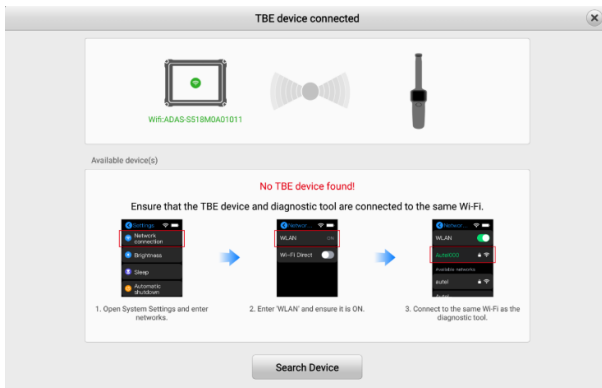

Figure 5-20 Connect with MaxiTPMS TBE Device 1

7. After the TBE device and the tablet are connected to the same Wi-Fi, tap the device you need in the available devices list to connect. Once the MaxiTPMS TBE device is connected, the connection status displays as "Paired."

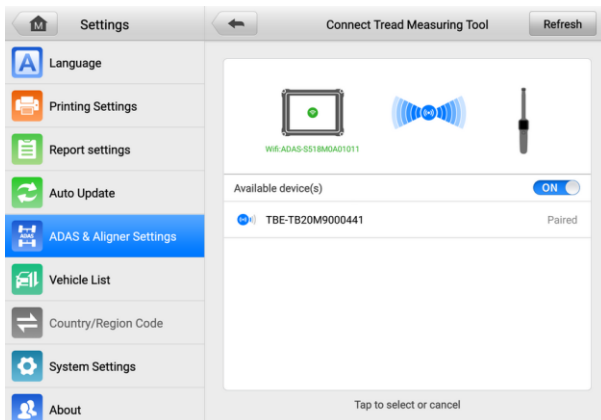

Figure 5-21 Connect with MaxiTPMS TBE Device 2

8. Tap the **Back** or **Home** button to exit the TBE Connection screen.

5.4.1.3 Chassis Inspection

Performing a chassis inspection can quickly and accurately troubleshoot the failure of chassis components and record the chassis inspection process.

Inspecting the chassis is mainly to inspect eight systems, including drivetrain, engine and transmission accessories, front suspension, rear suspension, front brake, master cylinder and booster, rear brake and steering. Each system has several subdivided inspection items. You can follow the operation guides on the tablet to inspect all the eight systems one by one, and you can also inspect some of the items by filtering. Tap one of the inspection items, then the component introduction, related symptoms, and repair method will be shown on the main section. Moreover, some inspection items have component schematic diagrams.

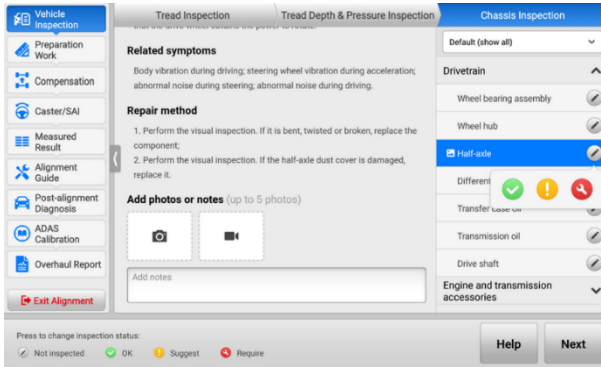

Figure 5-22 Chassis Inspection Screen 1







- a) According to the condition of the parts, you can tap the  icon to change the inspection status. For the explanation of each inspection status icon, you can tap the **Help** button for details.

Table 5-1 Inspection Status

Icon	Name	Explanation
	Not inspected	The part has not been inspected yet.
	OK	The part has been inspected, and no damage or wear is found.
	Suggest	<ol style="list-style-type: none"> 1. Part is close to the end of its useful life (just above discard specification, and a failure may occur soon). 2. To address a customer need, convenience or request (improve ride comfort, eliminate noise, etc.). 3. To comply with maintenance recommended by the Original Equipment Manufacturer (OEM). 4. Technician's recommendations based on substantial and informed experience. (Note: suggested service should always be optional. All the facts should be presented to the customer, allowing the customer to draw his own conclusions.)

Icon	Name	Explanation
	Require	<ol style="list-style-type: none"> 1. Part no longer performs the intended purpose. 2. Part does not meet a design specification. 3. Part is missing. (Note: when a repair is required, the shop must present all the facts to the customer and refuse partial service to the system in question, if the repair creates or continues an unsafe condition.)

- b) Tap the  button in the main section. You are able to take and upload up to 5 photos of the related component. Be noted that the button will disappear when more than 5 photos are taken. Tap the  button, and you can take and upload a video about the related component with a duration of 2 to 10 s. Please note that if the video duration is less than 2 s, the video recording is invalid. The button will disappear after shooting a video.
- c) Open the drop-down list in the upper-right corner of the screen. The parts that need to be inspected will be displayed in categories.

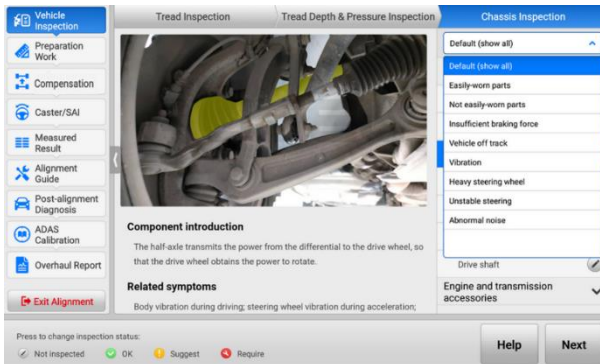

Figure 5-23 Chassis Inspection Screen 2

5.4.2 Preparation Work

For performing wheel alignment, the OE of some vehicle models has special requirements. To ensure the accuracy of the measurement results, the following preparations may be required before measuring the parameters related to wheel alignment.

1. Pre-alignment Notes
2. Diagnostics Functions
3. Ride Height Measurement

5.4.2.1 Pre-alignment Notes

Whether the vehicle's fuel tank, the spare tire, and the jack, are in their dedicated locations, will affect the measurement results during wheel alignment. Whether the comfort system of some advanced vehicle models is turned off will affect the installation of the brake pedal depressor and steering wheel holder stand tool. The OE has strict requirements on them. Therefore, it is necessary to carefully check the status of the vehicle according to the pre-alignment notes before performing wheel alignment.

According to the OE process, the pre-alignment notes vary by vehicle model. You need to carefully read and follow the pre-alignment notes.

Sample 1:

Check the vehicle status. This is an easy overlook but very important step.



Figure 5-24 Pre-alignment Notes 1

Sample 2:

For Mercedes-Benz vehicles, the operating procedures of disabling easy entry & exit will be listed on the Pre-alignment Notes screen. You need to follow the instructions to disable the easy entry & exit function before performing wheel alignment.

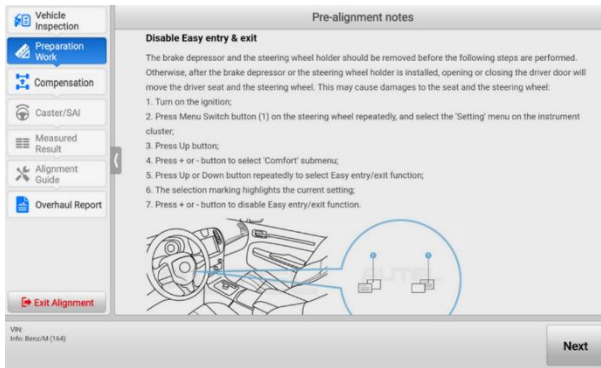

Figure 5-25 Pre-alignment Notes 2

5.4.2.2 Diagnostics Functions

To ensure accurate measurement results and successful wheel alignment procedures, the OE process of certain vehicle models may require performing related diagnostics functions (such as height adjustment, mode selection, RDC reset, etc.) before measuring the wheel alignment parameters.

NOTE

1. The diagnostics functions are only performed when you select **Advanced Wheel Alignment** in Wheel alignment application or the **Wheel Alignment** function in Diagnostics application.
2. The diagnostics functions vary by vehicle model. In the process of performing the diagnostics function, you need to read the notes carefully and follow the steps shown on the screen to operate.

✧ Height Adjustment (Take BMW vehicles as an example):

The height adjustment is required before measuring ride height in Load mode.

➤ **To perform height adjustment**

1. Follow the guides shown on the screen to operate. Ensure that the following conditions are met:
 - 1) The brake pedal depressor is already removed.
 - 2) The ignition is ON.
 - 3) The engine is OFF.
 - 4) The VCI is connected properly.

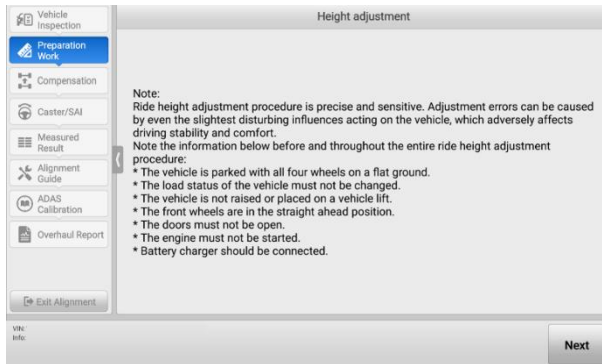

Figure 5-26 Height Adjustment Screen 1

2. If all the above conditions are met, tap **Next** to continue. Since the ride height adjustment procedure is precise and sensitive, adjustment errors can be caused by even the slightest disturbing influences acting on the vehicle, which adversely affects driving stability and comfort. So please carefully read the precautions for height adjustment and operate as required:
 - 1) The vehicle is parked with all four wheels on a flat ground.
 - 2) The load status of the vehicle must not be changed.
 - 3) The vehicle is not raised or placed on a vehicle lift.
 - 4) The front wheels are in the straight-ahead position.
 - 5) The doors must not be open.
 - 6) The engine must not be started.
 - 7) Battery charger should be connected.

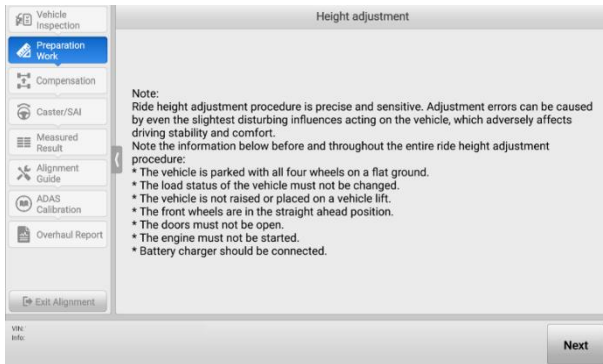

Figure 5-27 Height Adjustment Screen 2

3. Tap **Next** to continue if all the above conditions are met. The tablet will guide you to measure and enter the corresponding vehicle height value according to the actual situation.

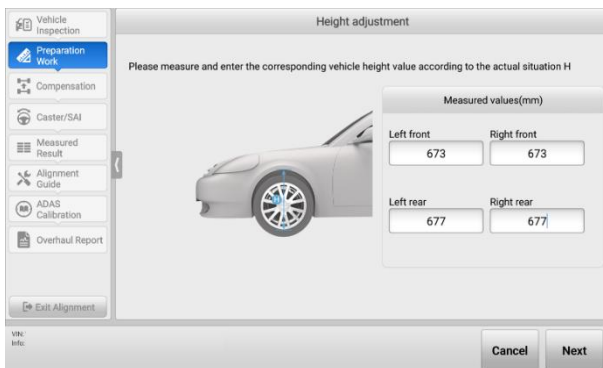

Figure 5-28 Height Adjustment Screen 3

4. After measuring and entering the vehicle height values, tap **Next** to write the values to the Vertical Dynamics Platform (VDP) control unit.

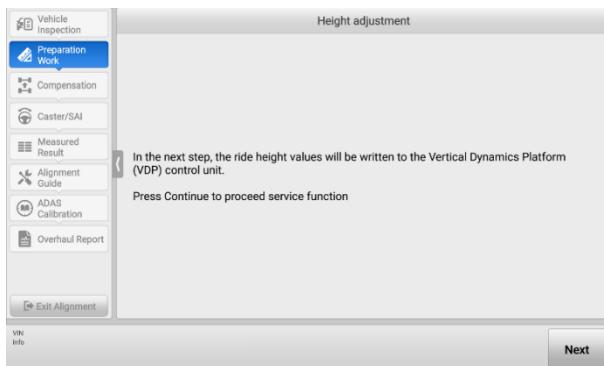

Figure 5-29 Height Adjustment Screen 4

5. Tap **Next** to continue. If the tablet displays the following screen, it indicates the ride height adjustment was successful.

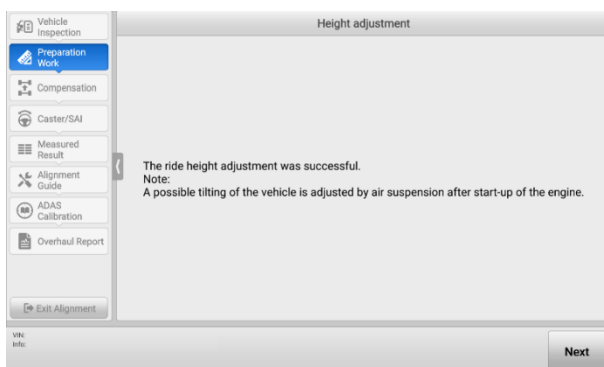

Figure 5-30 Height Adjustment Screen 5

5.4.2.3 Ride Height Measurement

The ride height measurement needs to be performed when the following conditions exist in the OE process of some vehicle models:

1. There is a standard value for the ride height.
2. The ride height value affects the standard value for wheel alignment.

NOTE

If the measured ride height value is not within the range of the standard value for ride height, you need to check if the vehicle body or the component on chassis is deformed or damaged.

1. Measure with tape or other tools

- a) For some vehicles, such as Volkswagen, there is a standard ride height. You can use tape measure or other tools to measure the ride height. Enter the values in corresponding input box after measuring.

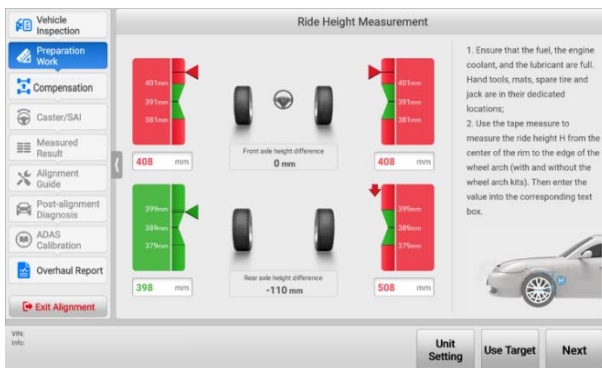

Figure 5-31 Measure Ride Height with Tape 1

- b) For some vehicles, such as Renault, there is no standard value for the ride height or a single tire needs to measure more than one value. You can also use tape measure or other tools to measure the ride height. Enter the values in corresponding input box after measuring.

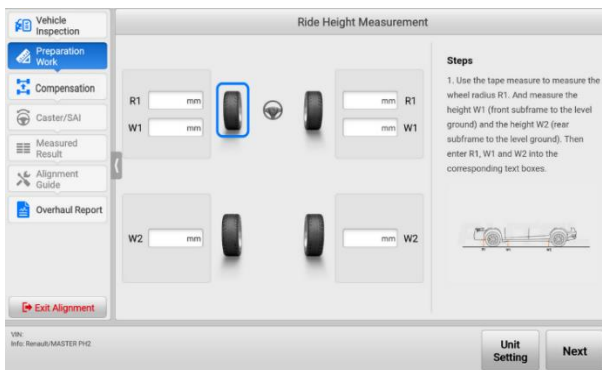

Figure 5-32 Measure Ride Height with Tape 2

2. Measure with ride height target

The ride height can be measured with ride height target if one of the following conditions is met:

- a) There is a standard value for the ride height, and the ride height is measured from the lower edge of wheel trim to the center of wheel rim.
- b) BMW vehicles which the ride height is measured from the lower edge of the wheel trim to the lower edge of wheel rim, and the rim size is selected before entering the whole wheel alignment procedures screen.

NOTE

1. A dedicated ride height target to measure the ride height is required, which can be purchased by contacting the local dealer or manufacturer.
2. After measuring the ride height, be careful to remove the ride height target, so as to avoid vehicle body damage.

To install a ride height target for ride height measurement

1. Follow the guide shown in the screen. Install the wheel clamps (rim clamps), wheel targets and ride height targets after ensuring the distance between the calibration frame and the front wheel center is within 2.03–3.30 m (7.23–10.83 ft).

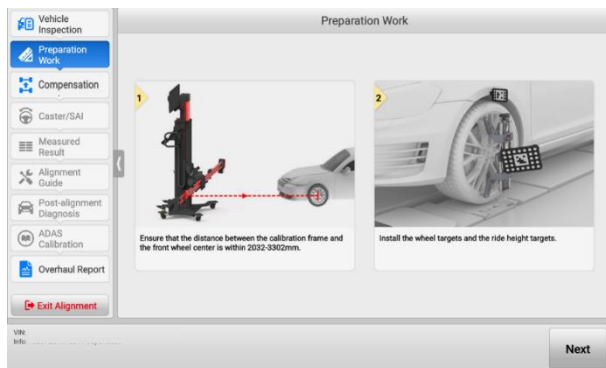

Figure 5-33 Install Ride Height Target

2. Tap **Next** to enter the following screen. The crossbar height will be automatically adjusted to search the targets. The ride height value will automatically display in the corresponding input box.



Figure 5-34 Measure Ride Height with Ride Height Target

3. Indicated by Tilt Angles

For some vehicles, such as Mercedes-Benz, the ride height is indicated by the tilt angles.

- a) Use the Inclination Sensor (for Mercedes-Benz) to measure the tilt angles of the corresponding chassis components, and enter the tilt angles into the corresponding input box.

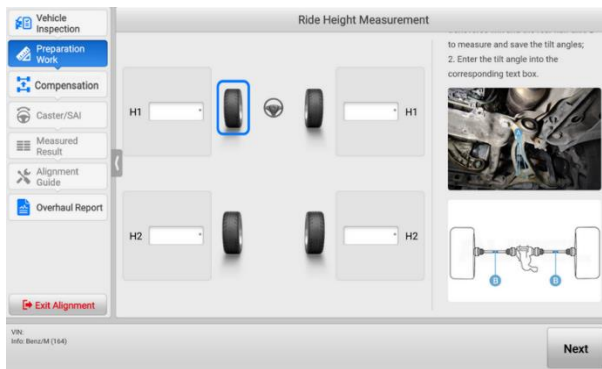

Figure 5-35 Measure and Input Tilt Angles

5.4.3 Compensation

This function is mainly used to compensate for errors caused when installing tools such as the wheel clamp (rim clamp/tire clamp) and target.

 **NOTE**

1. If the wheel clamp (rim clamp/tire clamp) or target is removed or loosened during compensation, it will result in inaccurate measurement results. In this case, you need to perform the compensation again.
 2. Do not obstruct the target during the compensation.
-

5.4.3.1 Rolling Compensation

1. Follow the guides shown in the tablet to complete the following preparations:
 - Insert the turnplate/slip plate pins and install the turnplate bridge.
 - Drive the vehicle on the alignment tack and place the wheel chocks to prevent movement.
 - Steer ahead; lock steering wheel; place transmission in neutral; and release parking brake.
 - Install the wheel clamps (rim clamps) and targets (if not previously installed).

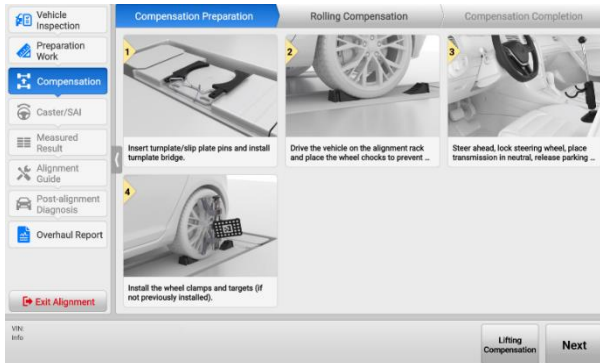

Figure 5-36 Rolling Compensation Preparations (Using Rim Clamp)

 **NOTE**

When driving the vehicle onto the lift, the width from the turntable bridge to each wheel should be the same, and the front wheel of the vehicle should stop at the center of the turnplate.

2. If the above preparations are completed, tap **Next**. The crossbar height will be adjusted automatically to search the targets, and the tablet will enter the following screen.

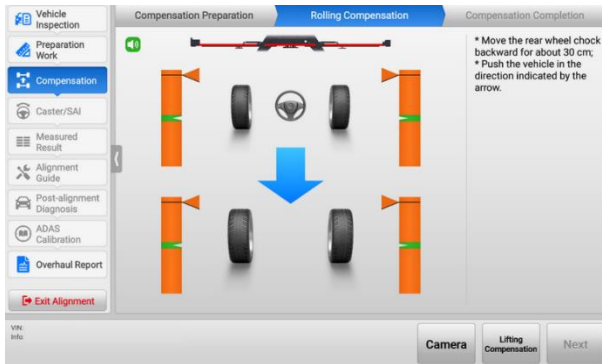

Figure 5-37 Start Rolling Compensation 1 (Using Rim Clamp)

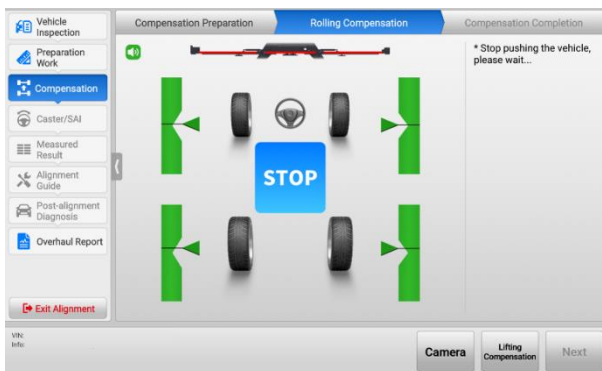

Figure 5-38 Start Rolling Compensation 2 (Using Rim Clamp)

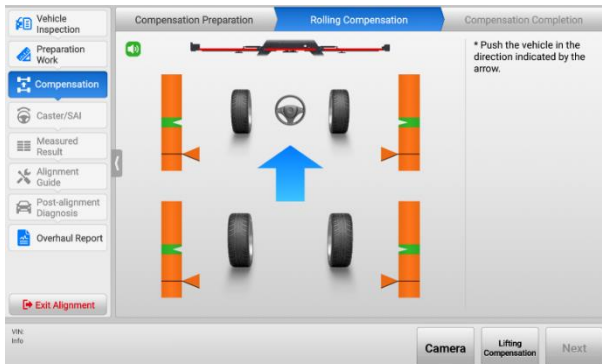

Figure 5-39 Start Rolling Compensation 3 (Using Rim Clamp)

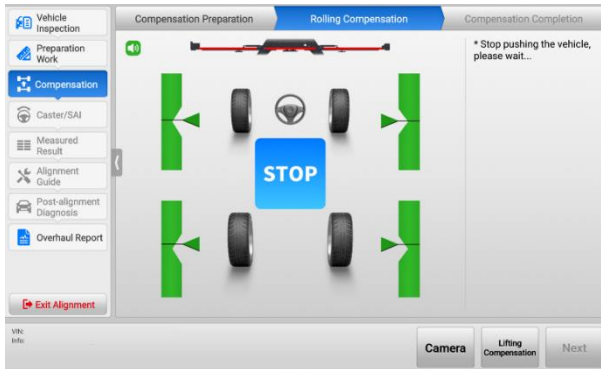

Figure 5-40 Start Rolling Compensation 4 (Using Rim Clamp)

3. Follow the guides above shown in the tablet. Push the vehicle backward and forward to complete the compensation.

NOTE

Do not touch the wheel clamps and targets when pushing the vehicle.

4. After the compensation is completed, the tablet will enter the next screen automatically. Follow the illustration shown in the tablet to place wheel chocks in the front and rear of the wheel to prevent wheel movement.

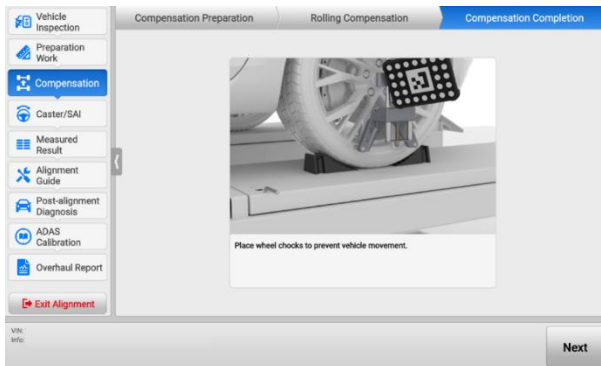

Figure 5-41 Complete Rolling Compensation (Using Rim Clamp)

5.4.3.2 Lifting Compensation

1. Follow the guides shown in the tablet to complete the preparations:
 - Steer ahead; lock steering wheel; place transmission in neutral; and release parking brake.
 - Raise the vehicle.
 - Install the wheel clamps (rim clamps) and targets (if not previously installed).

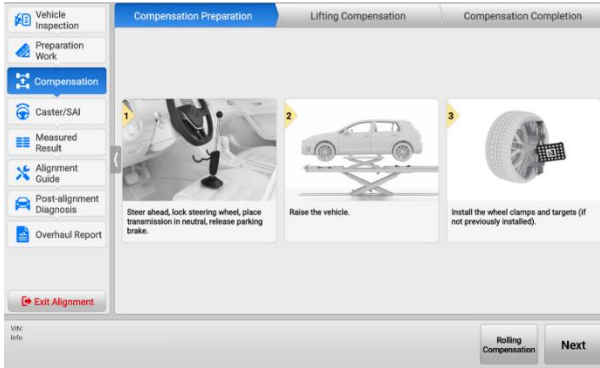

Figure 5-42 Lifting Compensation Preparation (Using Rim Clamp)

2. If the above preparations are completed, tap **Next**. The crossbar height will be adjusted automatically to search the targets, and the tablet will enter the following screen.

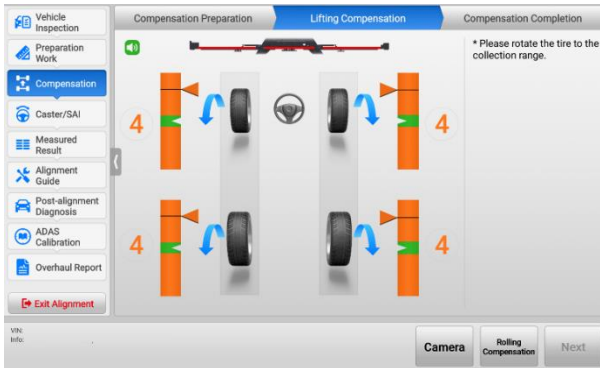

Figure 5-43 Start Lifting Compensation 1 (Using Rim Clamp)

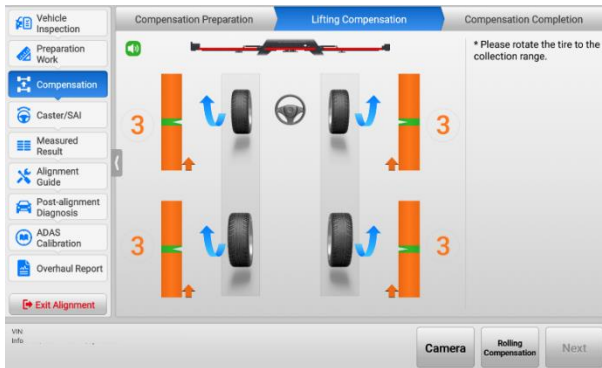

Figure 5-44 Start Lifting Compensation 2 (Using Rim Clamp)

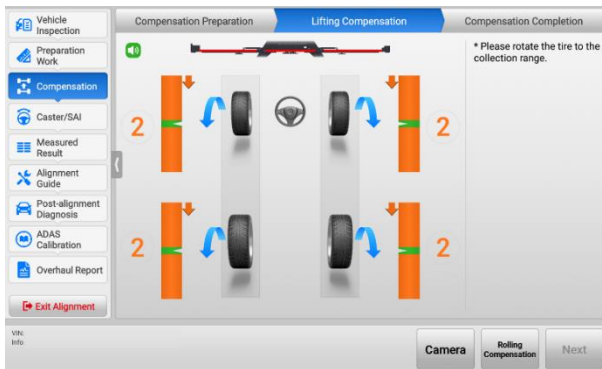

Figure 5-45 Start Lifting Compensation 3 (Using Rim Clamp)

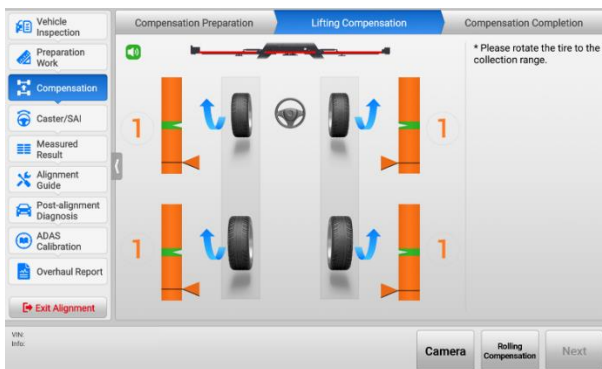

Figure 5-46 Start Lifting Compensation 4 (Using Rim Clamp)

3. Follow the guides above shown in the tablet. Rotate the tire to the collection range, and then stop.
4. After the collection is completed, the tablet will enter the following screen automatically. Follow the guides shown in the tablet to complete the following operations:
 - Remove the turnplate/slip plate pins and remove the turnplate bridge.
 - Lower the wheels and jounce the vehicle.
 - Place wheel checks to prevent vehicle movement.

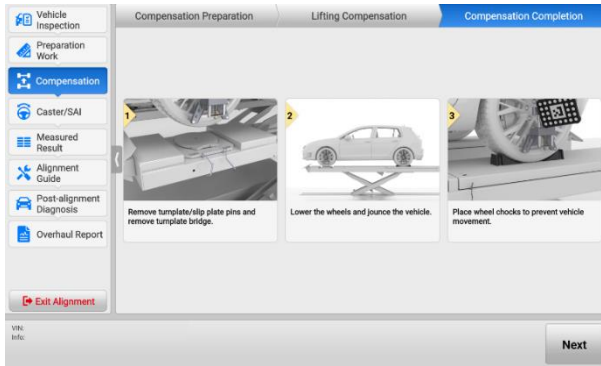

Figure 5-47 Complete Lifting Compensation (Using Rim Clamp)

NOTE

1. Make sure the four targets installed on wheels are level before lowering the vehicle. If the targets are not level, the subsequent measured results and wheel alignment results may be affected.
2. Before lowering the vehicle, the turnplate, slip plate pins, and turnplate bridge must be removed. Otherwise, the measurement results may be inaccurate due to the unnatural force on the vehicle.
3. Before lowering the vehicle, please shake the vehicle so that the components of the chassis are evenly stressed.

5.4.4 Caster/SAI/IA Angle Measurement

This function provides the guidance for measuring the Caster angle, SAI (Steering Axis Inclination) angle, IA (Included Angle) angle, toe-out on turns, and maximum steering angle. Measuring these angles can help in determining front suspension or steering system problems with a vehicle.

5.4.4.1 Select Measurement Angle

- a) The Caster angle, SAI angle and IA angle are selected for measurement by default, for these angles must be measured.
- b) If the toe-out on turns is selected for measurement, the Caster angle, SAI angle, IA angle, and toe-out on turns will be measured together.
- c) If the maximum steering angle is selected for measurement, the Caster angle, SAI angle, IA angle, and maximum steering angle will be measured together.
- d) If the toe-out on turns and the maximum steering angle are selected for measurement at the same time, the Caster angle, SAI angle, IA angle, toe-out on turns, and maximum steering angle will be measured together.

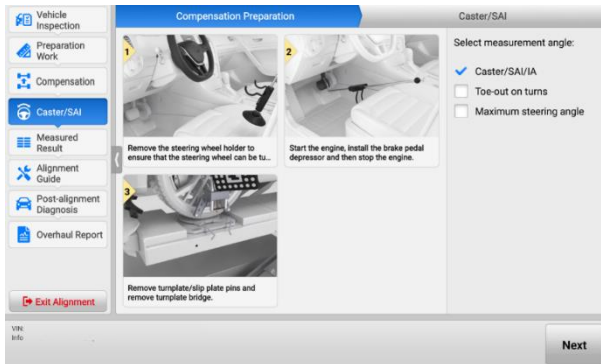

Figure 5-48 Caster/SAI/IA Measurement

5.4.4.2 Angle Measurement Preparation

Follow the guides shown in the tablet to complete the following operations:

1. Remove the steering wheel holder to ensure that the steering wheel can be turned.
2. Start the engine. Install the brake pedal depressor and then stop the engine.
3. Remove the turnplate/slip plate pins and remove the turntable bridge.
4. Install the maximum steering angle target on front wheels. (This operation is required only when the maximum steering angle needs to be measured.)

NOTE

1. If the brake pedal depressor is installed without starting the vehicle, inaccurate measurement results may be caused by the fact that the brakes are not locked.
 2. The measured results of toe-out on turns and maximum steering angle will be displayed on the Result Lists in Measured Result section.
-

5.4.4.3 Start Angle Measurement

After the above preparations are successfully made, tap **Next** to start angle measurement. Follow the guides shown in the tablet to turn the steering wheel left or right to the collection range step by step. Once the measurement procedures are completed, it will automatically enter the Measured Result section.

5.4.5 Measured Result

This section helps in:

1. Viewing the measured results about toe, camber, caster, symmetry value, rolling angle, and so on.
2. Viewing and changing the wheel specifications.

5.4.5.1 Graphical Result

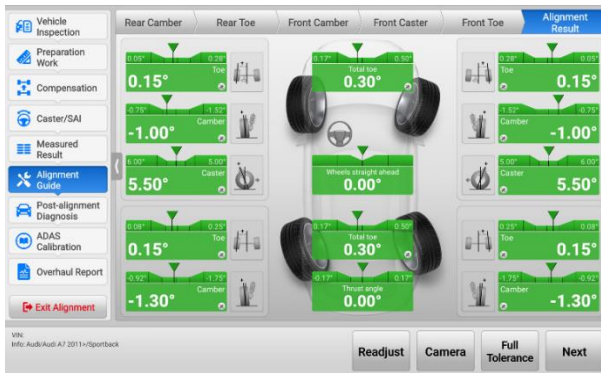

Figure 5-49 Measured Result Screen (Graphical Result)

- a) Tap the single image on the screen, then the selected image will be zoomed in. See as follows.

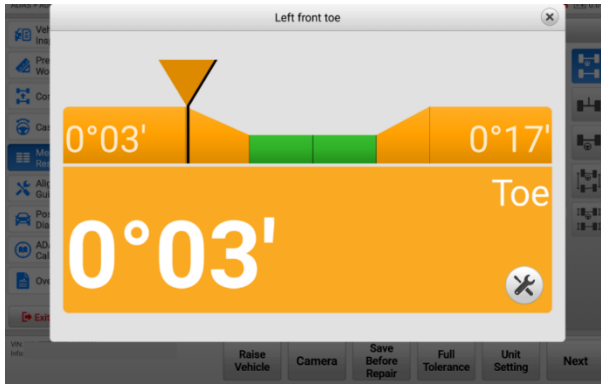





Figure 5-50 Zoom-in Image

- b) Tap the  button on the above screen to open the adjustment guide screen, then the adjustment guide about the image of the selected image will be displayed. You can follow the guides in the screen to adjust. If the adjustment is completed, tap  to exit the adjustment guide screen.
- c) Tap the buttons like  in the middle part of the screen to view the Parameter Descriptions, which are introduced in [Glossary](#).
- d) Tap the buttons like  in the right of the screen, then you can view the Graphical Result-Rear, the Graphical Result-Front, the Graphical Result-Symmetry Value, and the Graphical Result-Rolling Diameter, respectively.
- e) Tap the **Raise Vehicle** button to raise vehicle for adjustment. See [Raise Vehicle](#) for details.
- f) Tap the **Camera** button, then you can check the cameras' working condition.

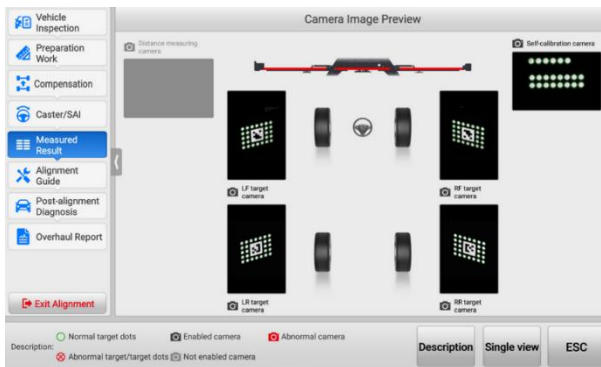







Figure 5-51 Camera Image Preview Screen

- The **Camera** button is always available when you need to check the cameras' working condition. Not limited to this screen.
- Tap **Description** to check the explanations for each icon displayed on the screen. See [Table 5-2 Camera Descriptions](#) for details.
- Tap **Full View** or **Single View** to change the preview method for the camera image.
- Tap **ESC** to exit the Camera Image Preview screen.

Table 5-2 Camera Descriptions

Icon	Name	Explanation
	Normal Target Dots	Target dots can be recognized normally.
	Abnormal Target/Target Dots	The target is dirty or blocked, clean it or remove the obstructions.
	Enabled Camera	The camera works normally.
	Not Enabled Camera	The camera is not used by the current function.
	Abnormal Camera	The tablet fails to communicate with the cameras. Follow the steps below: <ol style="list-style-type: none"> 1. Check if the power is ON; 2. Check if the current camera connection is normal; 3. Check if the diagnostic tool is connected to the camera Wi-Fi; 4. Record and upload logs. Fill in the problem description in detail.

- g) Tap **Save Before Repair** to save the measurements before alignment. If the measurements before repair are already saved, the tablet will prompt you and ask if you want to overwrite it.
- h) Tap **Full Tolerance** or **Half Tolerance** to change the graphical display mode from Full Tolerance and Half Tolerance.
- **Full Tolerance:** equals to OE specification's tolerance.
 - **Half Tolerance:** half of the OE specification's tolerance.

- i) Tap **Unit Setting** to change the units.
- j) Tap **Next** to enter Alignment Guide section. Be noted that if the measurements before repair are not saved, the tablet will ask you whether to save these specifications as measurements before repair.

5.4.5.2 Raise Vehicle

This function is suitable for vehicles that need to be lifted twice to adjust the wheel alignment parameters.

➤ To raise vehicle

1. Tap **Raise Vehicle** on the Measured Result screen.
2. Follow the guides shown in the tablet. You need to complete the following preparations before raising the vehicle:
 - 1) Set the steering wheel at center position. Lock the steering wheel.
 - 2) Start the engine. Install the brake pedal depressor and then stop the engine.

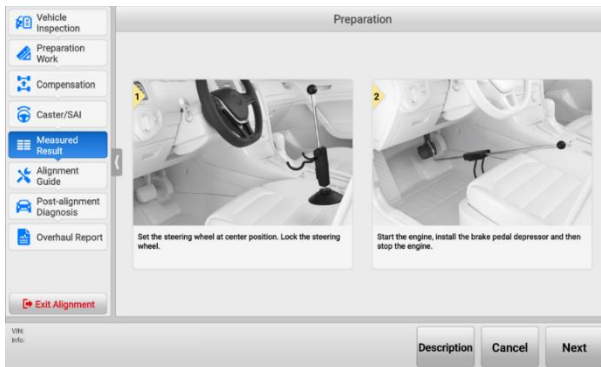

Figure 5-52 Raise Vehicle Preparations

3. Tap **Next** after the above preparations are completed. The tablet will start collecting data. In the process of collecting data, do not obstruct the targets. After the data is successfully collected, the tablet will enter the following screen. Follow the guide shown in the tablet to raise the vehicle and lock the lift.

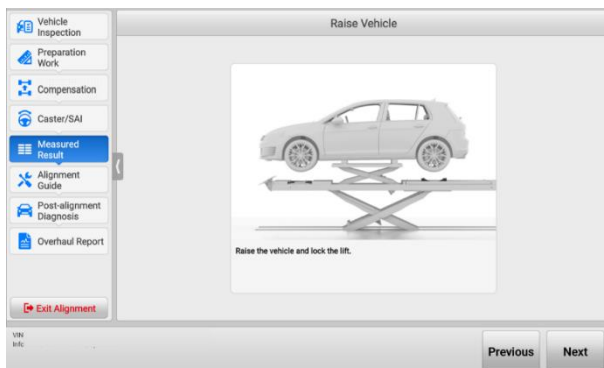

Figure 5-53 Raise Vehicle

4. After the vehicle is raised and the lift is locked, tap **Next** to collect data. The tablet will return to the Measured Result screen when the data is collected. Follow the guides on the Measured Result screen to perform adjustment.

➤ **To lower vehicle**

After raising the vehicle, the **Raise Vehicle** button on the Measured Result screen will switch to **Lower Vehicle**.

1. Tap the **Lower Vehicle** button on the Measured Result screen.
2. You can lower the vehicle as shown in the on-screen guides.
 - 1) Remove the turnplate/slip plate pins and remove the turnplate bridge.
 - 2) Lower the wheels and jounce the vehicle.
 - 3) Place wheel chocks to prevent vehicle movement.

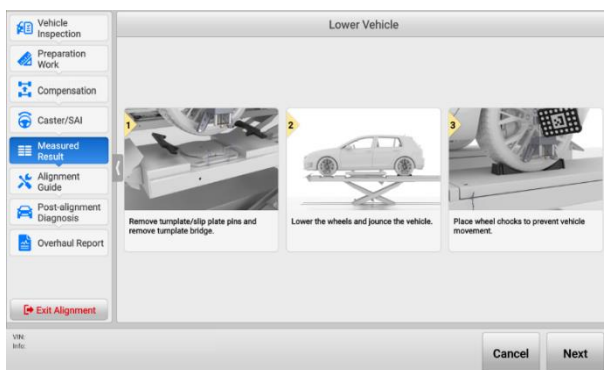

Figure 5-54 Lower Vehicle

3. After lowering the vehicle, tap **Next**. The tablet will return to the Measured Result screen.

5.4.5.3 Results List

The whole before repair results can also be displayed at a list, which look like the following illustration. You can save the list before alignment. The operations of the buttons in the Results list are same as those in Graphical Results screen.

Graphical Result			Results List	
	Left	Right	Front axle	Measured
Front axle				
Toe	0°03'	0°02'	Total toe	0°05'
Camber	-0°04'	0°01'	Cross camber	-0°05'
Caster	4°29'	3°31'	Cross caster	0°58'
SAI	-2°52'	3°19'	Cross SAI	-6°11'
IA	-2°56'	3°20'	Set back	0°01'
Toe-out on turns			Wheels straight ahead	0°01'
Left maximum steer	-34°59'	35°22'		--
Right maximum steer	34°41'	-34°22'		--
Ride Height	408mm	408mm		--
Rear axle			Rear axle	Measured
Toe	-1°53'	1°52'	Total toe	-0°01'

Figure 5-55 Measured Result Screen (Results List)

5.4.6 Alignment Guide

In the Alignment Guide section, the detailed alignment procedures with illustrations on the screen make the adjustment of wheel specifications more convenient and faster. In order to better guide users to operate, the alignment guide for some vehicle models includes adjustment animation.

NOTE

1. When adjusting the front toe, some vehicle models have both Normal Mode and Guide Mode. The Guide Mode is used by default. If you want to change the mode, tap **Normal Mode** or **Guide Mode** to switch.
2. To reduce the influence on front caster caused by the adjustment of other specifications, the caster angle needs to be remeasured before adjusting front caster.

5.4.6.1 Alignment Procedures

According to the OE process requirements, the detailed and complete alignment procedures will be provided to guide you to adjust the wheel specifications.

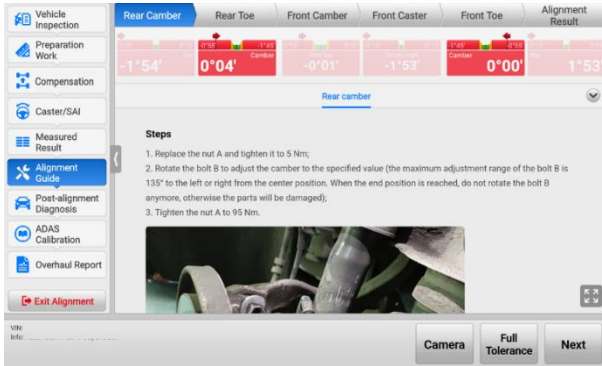

Figure 5-56 Parameters Adjustment Procedures Screen 1

- Follow the order on the top of the main section of the screen to complete all the adjustment procedures of wheel alignment parameters. The adjustment order is quite important, if the wheel alignment parameters are not adjusted according to the order (Rear Camber -> Rear Toe -> Front Caster -> Front Toe -> Alignment Result) displayed on the top of the main section, it may result in repeat operations.
- Check the highlighted red images on the screen, and adjust as shown in the on-screen guides. If the parameters of the angle are adjusted to correct values, the highlighted red images will turn highlighted green images. Then tap **Next** to adjust other parameters in the same way.
- For some wheel specifications, the OE process does not give an adjustment method. The tablet will display as below.

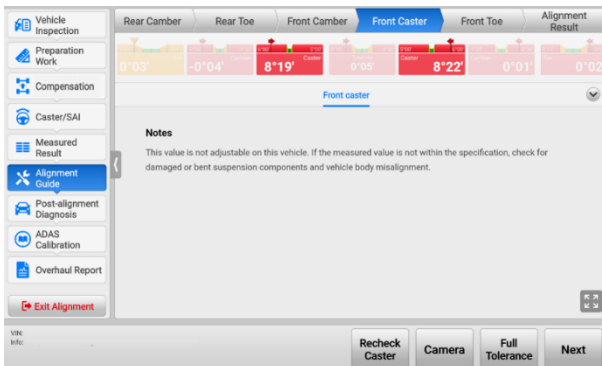

Figure 5-57 Parameters Adjustment Procedures Screen 2

- d) After completing all the wheel specifications adjustment procedures, tap **Next** to enter the Alignment Result screen. Check the image color (representing adjustment results) and make sure all the images are green. Otherwise, it needs to be readjusted.



Figure 5-58 Alignment Result Screen

5.4.6.2 Guide Mode on Front Toe

For some vehicle models, there are two modes to guide you to adjust the front toe, namely the Guide Mode and the Normal Mode. The Guide Mode helps you to achieve the purpose of adjusting the front toe by the left and right tie rod. It is much easier and quicker, so the Guide Mode is used by default.

In the Guide Mode, there are four steps for adjusting the Front Toe: preparation, adjust right tie rod, adjust left tie rod, and center steering.

1. Follow the guides shown in the tablet to complete the following preparations:
 - 1) Set the steering wheel at center position. (A steering wheel level is recommended.)
 - 2) Start the engine. Install the brake pedal depressor and then stop the engine.

NOTE

If the brake pedal depressor is installed without starting the vehicle, inaccurate measurement results may be caused by the fact that the brakes are not locked.

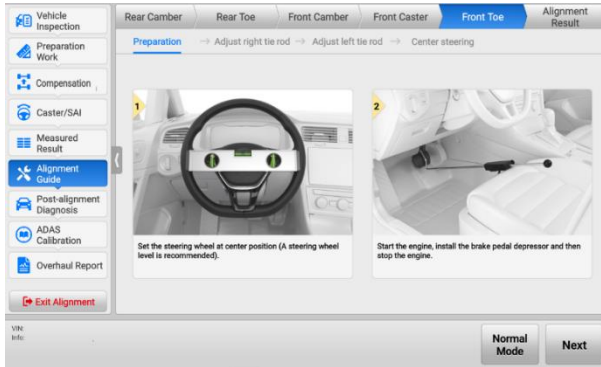

Figure 5-59 Front Toe Adjustment Preparation

2. When the above preparations are completed, tap **Next** to collect data and adjust right tie rod as shown in the on-screen guides.
 - 1) Loosen the lock nut and adjust the right tie rod to the tolerance range.
 - 2) Jounce the front part of the vehicle to set all bottom components in natural status.
 - 3) Tighten the lock nut.

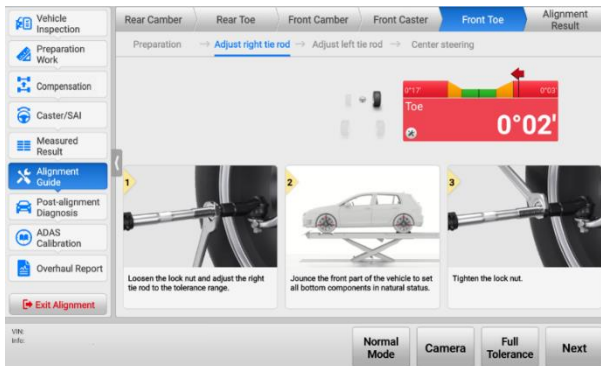

Figure 5-60 Adjust Right Tie Rod

3. If the right tie rod is adjusted well, tap **Next** to collect data and then enter the left tie rod adjustment guide screen.
 - 1) Loosen the lock nut and adjust the left tie rod to the tolerance range.
 - 2) Jounce the front part of the vehicle to set all bottom components in natural status.
 - 3) Tighten the lock nut.

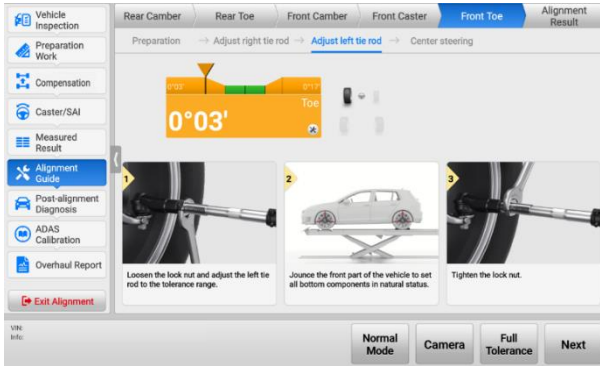

Figure 5-61 Adjust Left Tie Rod

4. After the left tie rod is well adjusted, tap **Next** to enter the center steering guide screen. Follow the guide shown in the tablet to set wheels straight-ahead. If the steering wheel is not centered, tap **Readjust** to adjust the front toe again.

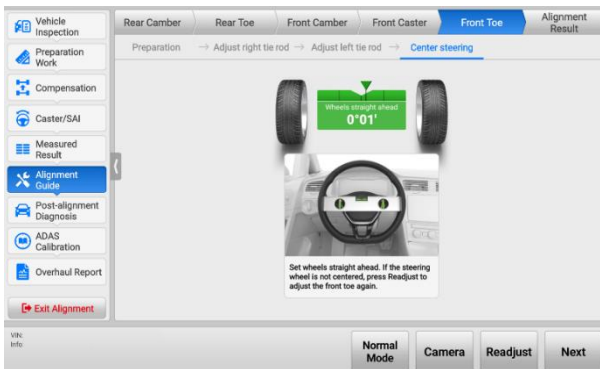

Figure 5-62 Center Steering

5.4.6.3 Recheck Caster

In some OE manuals, you need to recheck the caster angle after adjusting the front caster, so that the caster angle is within the standard range. When rechecking the caster, note that the crossbar and the vehicle should not be raised or lowered.

➤ To recheck caster

1. Tap the **Recheck Caster** button on the Front Caster screen. Follow the guides shown in the tablet to complete the following operations:
 - 1) Remove the steering wheel holder stand tool to ensure that the steering wheel can be turned.
 - 2) Start the engine. Install the brake pedal depressor and then stop the engine.
 - 3) Remove the turnplate/slip plate pins and remove the turnplate bridge.

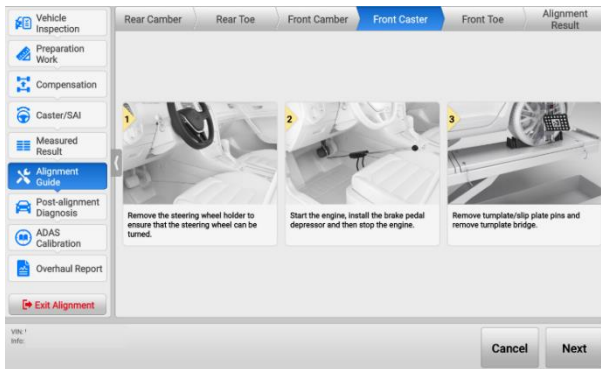

Figure 5-63 Recheck Caster Preparations

2. After completing the above preparations, tap **Next** to enter the next screen.
3. Follow the illustration guides shown in the tablet. Turn the steering wheel left or right to the collection range. If the steering wheel is centered, stop turning the steering wheel. The tablet will automatically return to the Front Caster screen.



Figure 5-64 Steering Wheel Adjustment

5.4.7 Post-alignment Diagnosis

Some vehicles need to perform related diagnostics functions like SAS reset after the wheel alignment parameters are adjusted.

5.4.7.1 Steering Angle Sensor (SAS) Reset

After adjusting the thrust angle and the toe angle, SAS reset is required under some circumstances. Failure to perform a SAS reset may affect the functionality of security systems such as VSC, ESC, TCS.

➤ To perform SAS reset

1. Follow the guides shown in the tablet to check if the following conditions are met:
 - 1) The brake pedal depressor is already removed.
 - 2) The ignition is ON.
 - 3) The engine is OFF.
 - 4) The VCI is connected properly.

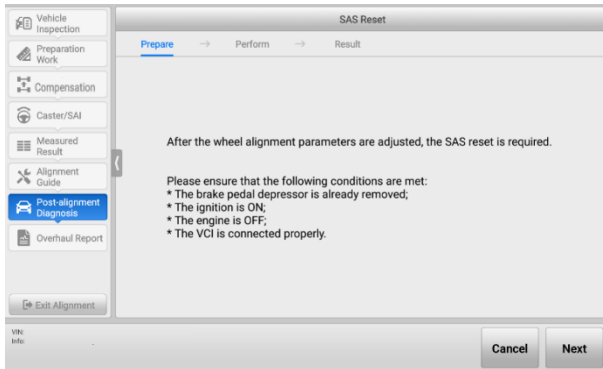

Figure 5-65 SAS Reset Screen 1

2. If the above conditions are met, tap **Next** to enter the next screen. Follow the on-screen guide. Turn the steering wheel slowly to the center position, set the front wheels straight-ahead, and release the steering wheel.

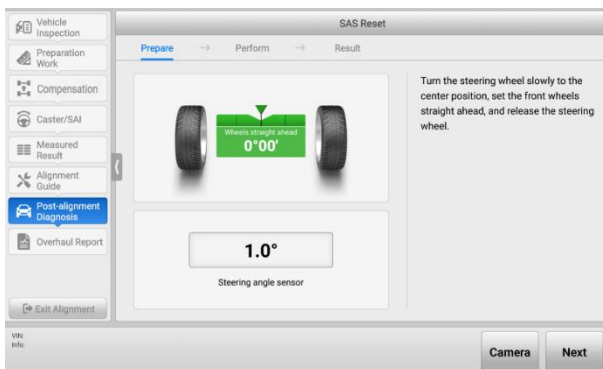

Figure 5-66 SAS Reset Screen 2

3. After that, tap **Next** to continue. Follow the on-screen instructions to turn the steering wheel to the right for about 30° and then perform the following steps:
 - 1) Turn the steering wheel slowly to the left end stop and hold for about 5 s;
 - 2) Turn the steering wheel slowly to the right end stop and hold for about 5 s;
 - 3) Turn the steering wheel slowly to the center position. Set front wheels straight-ahead, and release the steering wheel.

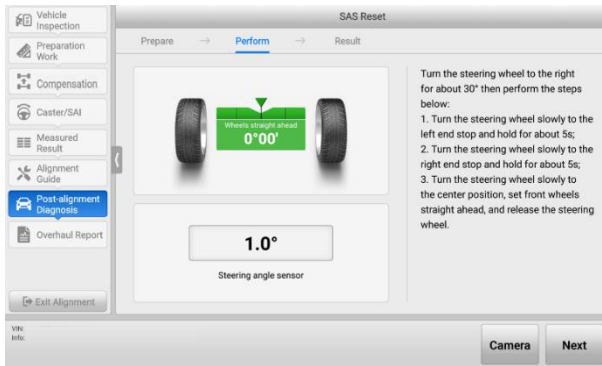



Figure 5-67 SAS Reset Screen 3

- If the above operations are completed, tap **Next** to enter the SAS reset result screen. If the screen displays , it indicates that the SAS reset is successful. If the screen displays , it indicates the SAS reset has failed.

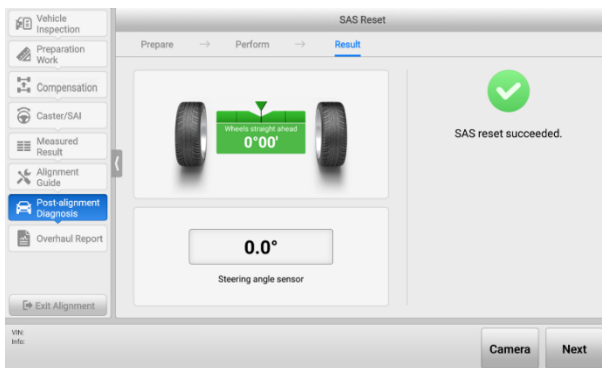

Figure 5-68 SAS Reset Screen 4

5.4.8 ADAS Calibration

After performing wheel alignment, to ensure the safety of vehicle driving, some ADAS functions need to be recalibrated.

The specific operations of ADAS calibration will be introduced in the later ADAS Calibration Function chapter. To know how to perform ADAS calibration, see [ADAS Calibration](#) for details.

5.4.9 Overhaul Report

In this section, after performing wheel alignment, you are able to:

- 1) Check the Wheel Alignment Report, the wheel alignment parameters, etc.
- 2) Save reports and share reports to cloud.

5.4.9.1 Fill in Customer Information

Before entering Overhaul Report, you need to complete customer information. See the customer information table as below, the items marked with * must fill in the corresponding information.

Figure 5-69 Customer Information Table

5.4.9.2 Report Types

Eight reports can be seen if all the functions are enabled during the whole wheel alignment procedures, including Wheel Alignment Report, Pre-repair & Post-repair Report, Pre-repair Report, Current Values Report, Symmetry Value Report, Chassis Inspection Report, Tire Inspection Report, and Ride Height Report.

- 1) Wheel Alignment Report: All inspection results, including tread depth, tire pressure, rolling diameter, ride height, front axle specifications, and rear specifications.

NOTE

1. The tread depth values and tire pressure values are available only when the tread depth & pressure inspection is performed.
 2. The ride height values are available only when the ride height measurement is performed.
-

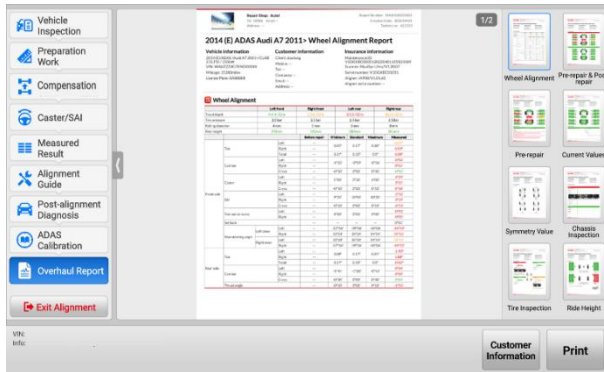



Figure 5-70 Overhaul Report Screen

- 2) Pre-repair & Post-repair Report: A graph showing the comparison of pre-repair results and post-repair results.
- 3) Pre-repair Report: A graph showing the pre-repair results. Additional symptom description will be listed if any of the measured value does not meet the specification value.
- 4) Current Values Report: A graph showing the current wheel alignment results. Additional symptom description will be listed if any of the current value does not meet the specification value.
- 5) Symmetry Value Report: A graph showing the vehicle axles, wheel axles, lateral offset, etc.
- 6) Chassis Inspection Report: Record chassis inspection data. Be noted that the Chassis Inspection Report is available only when the chassis inspection is performed.
- 7) Tire Inspection Report: Record the check data of tread condition, tread depth, and tire pressure. Be noted that the Tire Inspection Report is available only when the tread depth & pressure inspection is performed.
- 8) Ride Height Report: A graph showing the ride height or ride height difference. Be noted that the Ride Height Report is available only when the ride height measurement is performed.

5.4.10 Wheel Alignment Report Saving and Cloud Sharing

After performing vehicle inspection and wheel alignment, you can save the reports and share the reports to cloud, then share the cloud report via QR code, SMS or email to customers in real time.

1. In the Wheel Alignment Report screen, tap the  button from the top toolbar buttons to open the drop-down list.

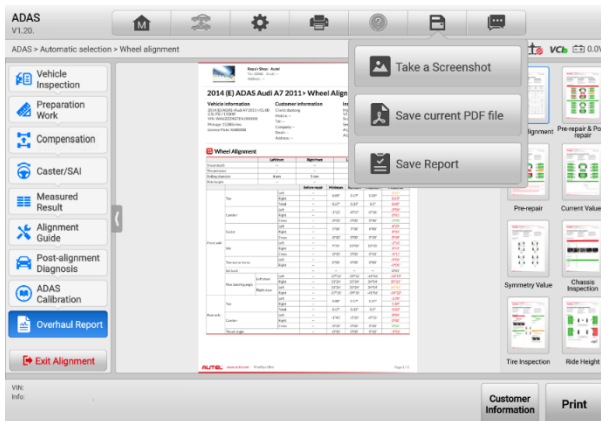

Figure 5-71 Save Report Screen 1

2. Tap the **Save Report** button from the drop-down list to enter the screen for selecting the reports that need to be saved.

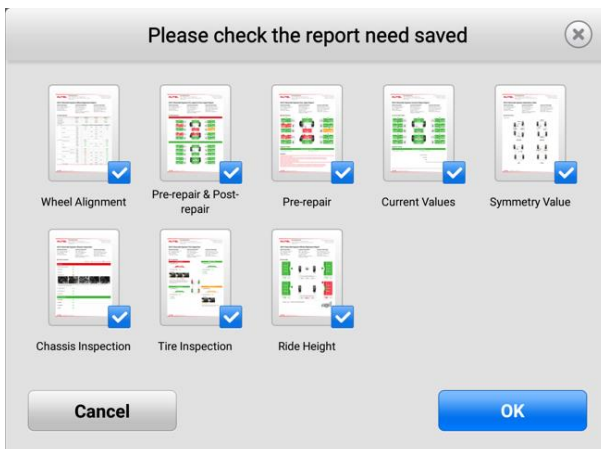

Figure 5-72 Save Report Screen 2

3. Tap **OK** after the reports that need to be saved are selected. If the tablet displays the following screen, it indicates that the reports are saved successfully.

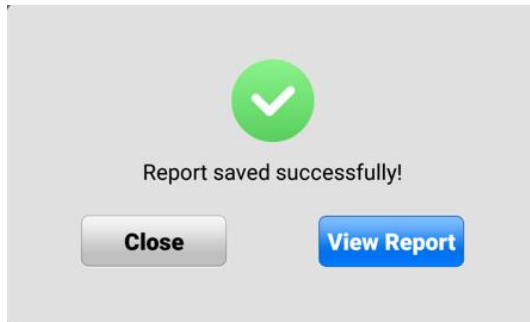

Figure 5-73 Save Report Screen 3

4. You can view local Wheel Alignment reports or share the saved Wheel Alignment reports with others via QR code, email, or phone number. The subsequent operations for Wheel Alignment report cloud sharing are the same with the operations for Diagnostic report cloud sharing. Refer to [Diagnostics Report Saving, Viewing, and Sharing](#) for details.

5.4.11 Glossary

5.4.11.1 Geometry Centerline

Refers to the intersection of the longitudinal center plane of the body and the horizontal plane of the front and rear axles (blue dotted line).

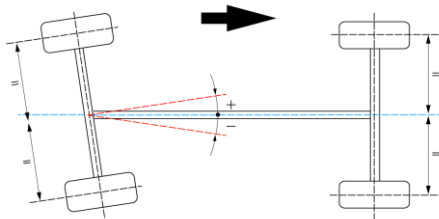

5.4.11.2 Thrust Angle

◇ Definition

The thrust angle is the angle between the longitudinal geometric center plane of the vehicle and the thrust line (the driving axis is the perpendicular line of the rear axle center). As shown in the picture below.

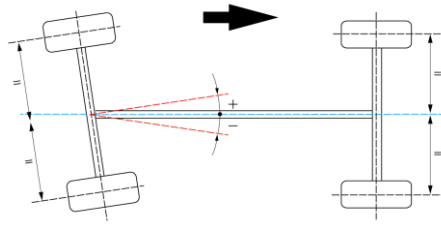

✧ Function

Ensure that the vehicle is driven straight-ahead.

✧ Effects of abnormal thrust angle

- The steering wheel is tilted when the vehicle is driven straight-ahead.
- The tires are abnormally worn and the vehicle pulls to one side.

5.4.11.3 Toe

✧ Definition

The toe is the angle between the center plane of the wheel rotation and the longitudinal plane of the vehicle (as shown in the picture below).

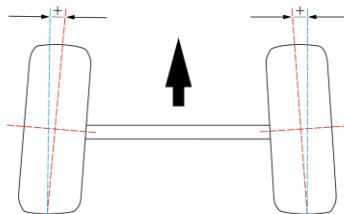

✧ Function

Eliminate or reduce the adverse effect when the front ends of the two wheels spread outward due to the camber in driving. Ensure that the wheels do not roll outwards. Prevent the wheels from sliding laterally. And reduce tire wear and fuel consumption.

✧ Effects of abnormal toe

- One side of the tire is abnormally worn.
- The vehicle has excessive vibrations when driving at high speed.
- The steering wheel is tilted when driving straight-ahead.

5.4.11.4 Total Toe

The sum of the toe-in of the coaxial left and right wheels.

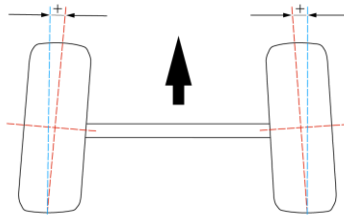

5.4.11.5 Camber

◇ Definition

The camber is the angle between the wheel rotation plane and the longitudinal plane perpendicular to the vehicle bearing plane. If the upper of the wheel is tilted outward relative to the rotation plane, it is the positive camber. If the upper of the wheel is tilted inward, it is the negative camber (as shown in the picture below).

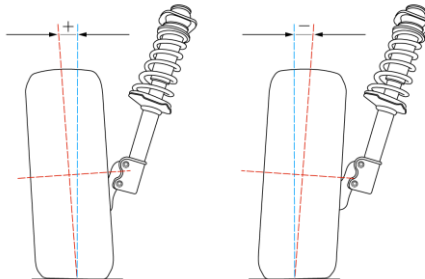

◇ Function

Improve the safety of the front wheels and make the steering lighter when driving.

◇ Effects of abnormal camber

- When the camber is too large, the outer side of the wheel is worn. The vehicle has excessive vibrations and the steering wheel is unstable when driving at high speed.
- When the camber is too small, the inner side of the wheel is worn. The steering is heavy and there is not enough force to return the steering wheel automatically to the center position.
- When the left camber and the right camber are not equal, the vehicle slides laterally and deviates when driving.

5.4.11.6 Front Caster

◇ Definition

The kingpin is the center of rotation when the wheel is turning. The caster is the angle between the kingpin axis and the perpendicular line of the vehicle bearing plane (as shown in the picture below).

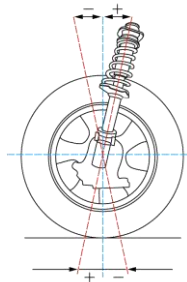

◇ Function

Create the force to return the steering wheel automatically to the center position. Ensure the vehicle stability when driving straight-ahead. And make the steering wheel lighter and easier to return after the vehicle changes direction.

◇ Effects of abnormal caster

- When the left caster and the right caster are not equal, the left wheels are not synchronized with the right wheels when the vehicle changes direction. And, the vehicle deviates when driving.
- When the caster is too small, the steering wheel is unstable.
- When the caster is too large, the steering is heavy.

5.4.11.7 Steering Axis Inclination (SAI)

✧ Definition

The steering axis inclination is the angle between the kingpin axis and vertical line in the lateral vertical plane of the vehicle (as shown in the picture below).

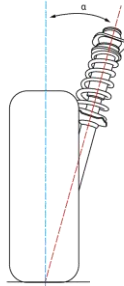

✧ Function

When the wheels deviate from the straight-ahead position due to external force, the front wheels will automatically return to the straight-ahead position.

✧ Effects of abnormal steering axis inclination

- When the steering axis inclination is too large, the required steering force becomes larger and the steering becomes difficult.
- When the steering axis inclination is too small, the steering system cannot fully return to the center position after the vehicle makes a turn.
- When the left steering axis inclination and the right steering axis inclination are not equal, the vehicle may pull to one side.

5.4.11.8 Included Angle (IA)

✧ Definition

The included angle is the angle γ between the kingpin axis and the wheel axis. The value of the included angle is the sum of the steering axis inclination α and the camber β (as shown in the picture below).

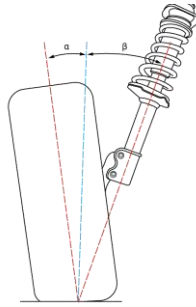

✧ Function

The included angle is used for diagnosing the suspension system misalignment and the suspension components deformation.

✧ Effects of abnormal included angle

- When the included angle is too small, the steering axis inclination is normal and the camber is too small, the shaft journal may be bent.
- When the included angle is normal, the steering axis inclination is too small and the camber is too large, the lower control arm may be bent.
- When the included angle is normal, the steering axis inclination is too large and the camber is too small, the upper control arm may be bent.
- When the included angle is too large, the steering axis inclination is too small and the camber is too large, the lower control arm and the shaft journal may be bent.

5.4.11.9 Toe-out on Turns

✧ Definition

The Ackerman angle is the difference between the outer wheel steering angle and the inner wheel steering angle when the vehicle makes a turn.

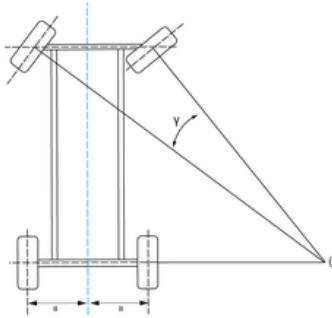

✧ Function

Ensure that the two front wheels point to the correct direction for more grip.

✧ Effects of abnormal Ackerman angle

- The tires may have feathering condition.
- The tires may slide laterally or jump or have abnormal noise due to insufficient grip when the vehicle makes a turn.

5.4.11.10 Maximum Steering Angle

✧ Definition

The maximum steering angle is the angle that the wheel rotation plane covers when the front wheels turn from the straight-ahead position to the left or right limit position.

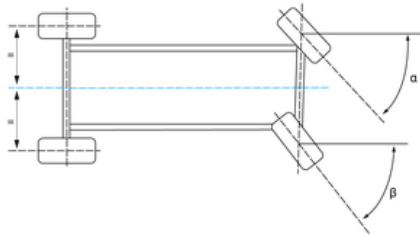

✧ Function

Control the minimum turning radius and ensure the vehicle driving stability and maneuverability.

✧ Effects of abnormal maximum steering angle

- The vehicle may slide during driving.

- There may be noise when the vehicle makes a turn.
- The steering wheel may shake.
- The steering is heavy.
- In extreme cases, the vehicle may roll over.

5.4.11.11 Ride Height

The location and method of ride height vary by vehicle manufacturer. See below for details.

- Ride height of vehicle manufacturers such as Volkswagen, Audi, Porsche, etc.

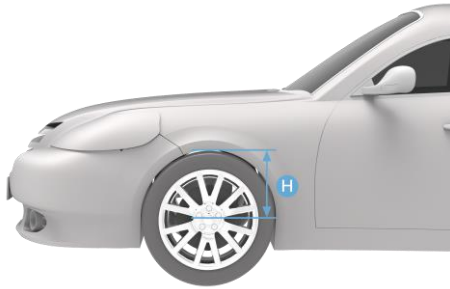

- Ride height of vehicle manufacturers such as BMW.

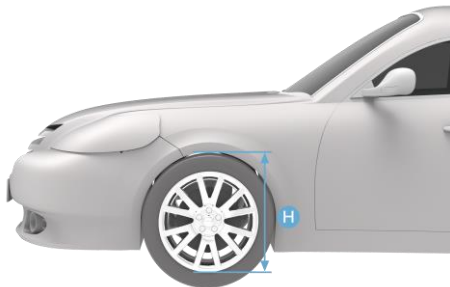

- Ride height of vehicle manufacturers such as Mercedes-Benz, Maybach, and etc., determined by measuring the inclination of chassis-related components.

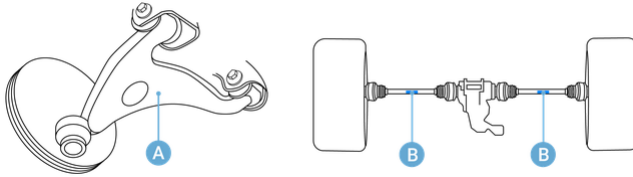

- Ride height of vehicle manufacturers such as Renault, Peugeot, more than one value that needs to be measured on one tire position.



5.4.11.12 Setback Angle

✧ Definition

The setback angle is the angle between the vertical line of the wheel center connecting line and the thrust line.

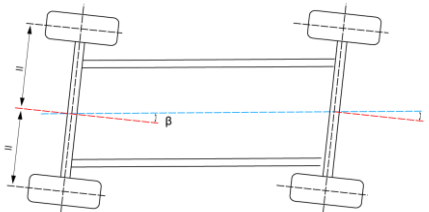

✧ Function

To diagnose the axle deformation.

✧ Effects of abnormal setback angle

- The setback angle leads to the difference between the left and right wheelbases, and the vehicle pulls to the side of shorter wheelbase.

5.4.11.13 Wheel Straight-ahead

Half of the difference value of front wheel left toe minus right toe.

5.4.11.14 Symmetrical Value

The geometric dimensions of the vehicle are usually symmetrical, which is used to preliminarily judge whether the vehicle has had an accident and the health status of the chassis, and assist the four-wheel alignment.

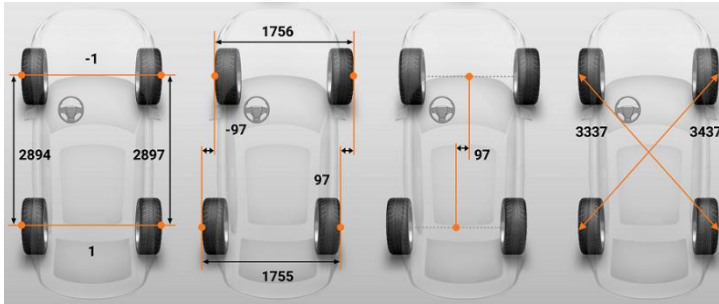

5.4.11.15 Rolling Diameter

The rolling radius R is equal to the distance from the center of the wheel to the ground. The rolling diameter is equivalent to two rolling radius R .

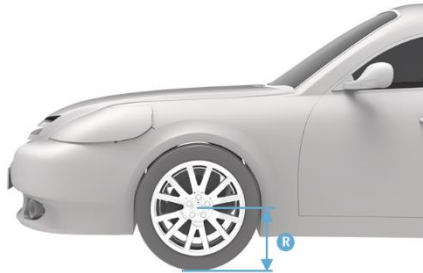

5.5 Perform Diagnostics Function & ADAS Calibration

5.5.1 Before Wheel Alignment

Some vehicles with air suspension require performing diagnostic function before performing wheel alignment. Only when the vehicle is set to the standard height, the wheel alignment parameters can be accurately measured and adjusted.

5.5.2 After Wheel Alignment

Many vehicles need to perform diagnostic functions (e.g. steering angle sensor calibration, set power steering gear) after performing wheel alignment if the toe is changed. Vehicles with ADAS systems such as front cameras need to calibrate the relevant ADAS systems.

6 ADAS Calibration

After connecting with IA900WA, MaxiSys ADAS diagnostic tablet allows you to perform ADAS calibration function by utilizing various sensors installed on the vehicle, including Adaptive Cruise Control (ACC), Blind Spot Detection (BSD), Rear View Camera (RVC), Lane Keep Assist (LKA), Around View Monitoring (AVM), Night Vision System (NVS), and so on.

This chapter describes the calibration procedures (take Audi A7 2011 vehicle as an example) of six different ADAS calibration functions, namely ACC calibration, camera system rear view calibration, HUD calibration, camera system rear view calibration, night vision camera calibration, and on-board camera calibration. On which situation that needs calibration, the required calibration tools, the calibration preparations, notes, and procedures are introduced in detail. As the calibration procedures may vary by vehicles, please follow the step-by-step instructions on the compatible diagnostic tablet to complete the calibration.

6.1 Preparatory Work

Before performing wheel alignment, please check and set:

1. The tablet is connected with IA900WA Wi-Fi and Internet accessible network. See [Calibration Frame Connection](#) and [Network Configuration](#) for details.
2. Depending on the tools and experience you have, select the clamp type in Settings first. Here we select **Rim clamp** (the default setting) for illustration.
3. Proper communication between vehicle and tablet is established. Please see [Establish Vehicle Communication and Selection](#) for details.
4. The IA900WA is connected to the charger to avoid the battery power loss, for the whole ADAS calibration procedure may take a long time.

6.2 Vehicle Communication and Selection

The ADAS calibration function is integrated into the Diagnostics application. To access to the ADAS calibration function, please refer to [Establish Vehicle Communication and Selection](#) to establish a proper communication between the vehicle and the tablet, and follow the on-screen guides to operate step by step, and finally enter the main function screen in the Diagnostics application. For vehicles that support ADAS calibration function, the ADAS Calibration function will be listed on the main menu on the left side of the

screen in the Diagnostics application. Then select **ADAS calibration** to display the specific ADAS calibration function.

6.2.1 Specific ADAS Calibration Function

All the ADAS calibration functions will be listed in the right of the screen, mainly including Adaptive Cruise Control, Lane Change Assistant, Camera System Rear View, Head Up Display, Night Vision, On-Board Camera, and so on.

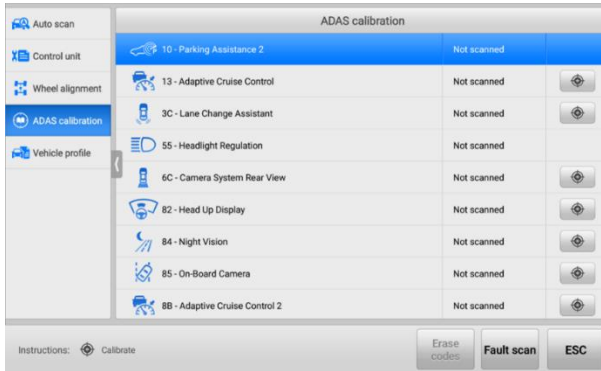

Figure 6-1 Complete ADAS Calibration Function Screen

6.2.1.1 Adaptive Cruise Control

The ACC (Adaptive Cruise Control) system enables the driver to maintain a calibrated distance from the vehicle ahead. According to the distance and speed of the selected vehicle, the vehicle can realize automatic deceleration and acceleration.

6.2.1.2 Lane Change Assistant

Since there is a visual blind spot in the rearview mirror of the vehicle, the vehicle in the blind spot cannot be seen before changing lanes. If there is an overtaking vehicle in the blind spot, a collision accident may occur when changing lanes. Blind spot detection system can sweep out the blind spot of the rearview mirror, so as to avoid accidents during lane changing.

6.2.1.3 Camera System Rear View

The panoramic camera system, having cameras for providing a secure 360° view, can transmit the images around to the cab in real time, so that the driver can accurately grasp the environmental conditions at close range.

6.2.1.4 Head Up Display

Head up display is abbreviated as HUD. HUD is a transparent or miniature display for presenting vehicle dashboard data, such as speed and navigation, on the windshield in front of the driver, so that the driver can see them easily without looking down or turning his head, and can keep focused on the road ahead

6.2.1.5 Night Vision System

The night vision system with thermographic camera contributes to optimize the visibility during night driving, so that the drivers can gain more awareness on road condition, vehicle condition, and so on.

6.2.1.6 On-Board Camera

The on-board camera system is designed to warn the driver when the vehicle begins to move out of its lane on freeways and arterial roads. The system aims to minimize accidents caused by driver error, distraction and drowsiness.

6.3 ADAS Calibration Procedures

Since the ADAS calibration procedures are detailed illustrated on the tablet, you can follow the on-screen instructions to complete the related ADAS calibration step by step. The procedures for all ADAS calibration functions mainly include the following parts: select a situation that needs calibration, required calibration tools, calibration preparations, position auxiliary tools for calibration. Here we select **Adaptive Cruise Control** as a sample for illustrating the main parts.

6.3.1 Select a Situation That Needs Calibration

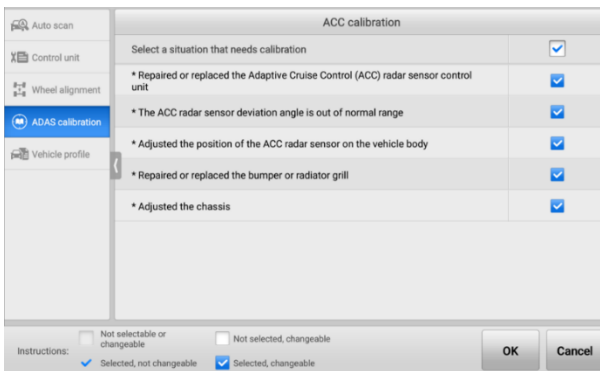

Figure 6-2 Select ACC Calibration Situations

6.3.2 Required Calibration Tools

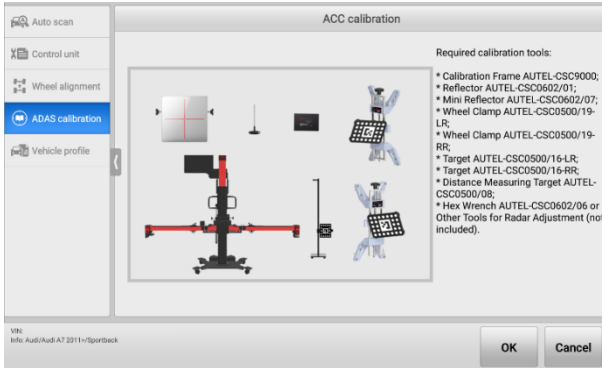

Figure 6-3 Prepare ACC Calibration Tools

6.3.3 Calibration Preparations

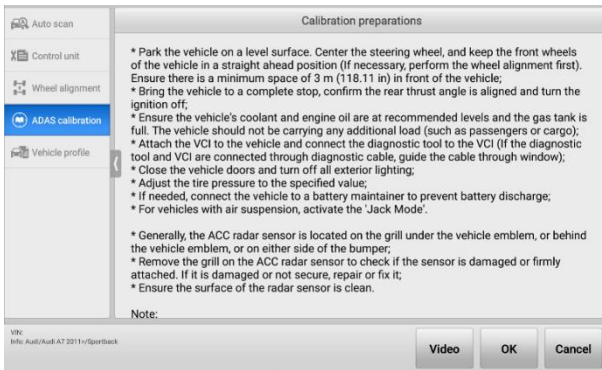

Figure 6-4 ACC Calibration Preparations

6.3.4 Auxiliary Tool Positioning

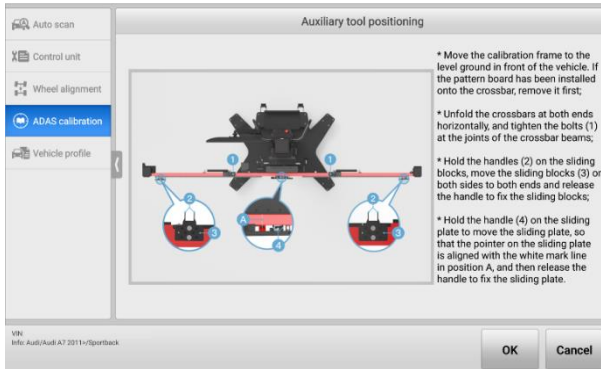

Figure 6-5 *Position Auxiliary Tools for Calibration*

7 Service

The Service section is specially designed to provide quick access to the vehicle systems for various scheduled service and maintenance tasks. The typical service operation screen is a series of menu driven executive commands. Follow on-screen instructions to select appropriate execution options, enter correct values or data, and perform necessary actions. The application will display detailed instructions to complete selected service operations.

After entering each special function, the screen will display two application choices: Diagnosis and Hot Functions. The Diagnosis enables the reading and clearing of codes which is sometimes necessary after completing certain special functions. Hot Functions consists of sub functions of the selected special function.

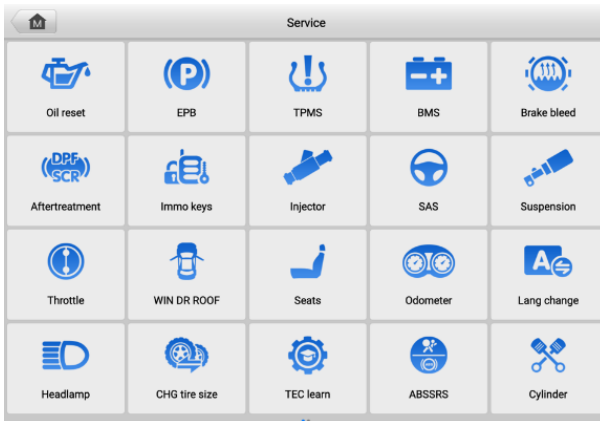

Figure 7-1 Service Menu

Several most commonly used services are described in this chapter.

7.1 Oil Reset Service

Perform reset for the Engine Oil Life system, which calculates an optimal oil life change interval depending on the vehicle driving conditions and climate. The Oil Life Reminder must be reset each time the oil is changed, so the system can calculate when the next oil change is required.

 **NOTE**

1. Always reset the engine oil life to 100% after every oil change.
 2. All required work must be carried out before the service indicators are reset. Failure to do so may result in incorrect service values and cause DTCs to be stored by the relevant control module.
 3. For some vehicles, the scan tool can reset additional service lights such as maintenance cycle and service interval. On BMW vehicles for example, service resets include engine oil, spark plugs, front/rear brakes, coolant, particle filter, brake fluid, micro filter, vehicle inspection, exhaust emission inspection and vehicle checks.
-

7.2 Electric Parking Brake (EPB) Service

This function has a multitude of usages to maintain the electronic braking system safely and effectively. The applications include deactivating and activating the brake control system, assisting with brake fluid control, opening and closing brake pads, and setting brakes after disc or pad replacement.

7.2.1 EPB Safety

It can be dangerous to perform Electric Parking Brake (EPB) system maintenance, so before you begin the service work, please keep these rules in mind.

- ✓ Ensure that you are fully familiar with the braking system and its operation before commencing any work.
- ✓ The EPB control system may be required to be deactivated before carrying out any maintenance/diagnostic work on the brake system. This can be done from the tool menu.
- ✓ Only perform maintenance work when the vehicle is stationary and on level ground.
- ✓ Ensure that the EPB control system is reactivated after the maintenance work has been completed.

 **NOTE**

Autel accepts no responsibility for any accident or injury arising from the maintenance of the Electric Parking Brake system.

7.3 Tire Pressure Monitoring System (TPMS) Service

This function allows you to quickly look up the tire sensor IDs from the vehicle ECU, as well as to perform TPMS replacement and reset procedures after tire sensors are replaced.

7.4 Battery Management System (BMS) Service

The Battery Management System (BMS) allows the tool to evaluate the battery charge state, monitor the close-circuit current, register the battery replacement, activate the rest state of the vehicle, and charge the battery via the diagnostic socket.

NOTE

1. This function is not supported by all vehicles.
 2. The sub functions and actual test screens of the BMS may vary by vehicle, please follow the on-screen instructions to make correct option selection.
-

The vehicle may use either a sealed lead-acid battery or an Absorbed Glass Mat (AGM) battery. Lead acid battery contains liquid sulphuric acid and can spill when overturned. AGM battery (known as VRLA battery, valve regulated lead acid) also contains sulphuric acid, but the acid is contained in glass mats between terminal plates.

It is recommended that the replacement aftermarket battery has the same specifications, such as capacity and type, as the exiting battery. If the original battery is replaced with a different type of battery (e.g. a lead-acid battery is replaced with an AGM battery) or a battery with a different capacity (mAh), the vehicle may require reprogramming of the new battery type, in addition to, performing the battery reset. Consult the vehicle manual for additional vehicle-specific information.

7.5 Diesel Particle Filter (DPF) Service

The Diesel Particle Filter (DPF) function manages DPF regeneration, DPF component replacement teach-in and DPF teach-in after replacing the engine control unit.

The ECM monitors driving style and selects a suitable time to employ regeneration. Cars driven a lot at idling speed and low load will attempt to regenerate earlier than cars driven more with higher load and speed. For regeneration to take place, a prolonged high exhaust temperature must be obtained.

In the event of the car being driven in such a way that regeneration is not possible, i.e., frequent short journeys, a diagnostic trouble code will eventually be registered in addition to the DPF light and "Check Engine" indicators displaying. A service regeneration can be requested in the workshop using the diagnostic tool.

Before performing a forced DPF regeneration using the tool, check the following items:

- The fuel light is not on.
- No DPF-relevant faults are stored in system.
- The vehicle has the specified engine oil.
- The oil for diesel is not contaminated.

! IMPORTANT

Before diagnosing the problematic vehicle and attempting to perform an emergency regeneration, it is important to obtain a full diagnostic log and read out relevant measured value blocks.

🔧 NOTE

1. The DPF will not regenerate if the engine management light is on, or there is a faulty EGR valve.
 2. The ECU must be re-adapted when replacing the DPF and when topping up the fuel additive Eolys.
 3. If the vehicle needs to be driven in order to perform a DPF service, a second person is needed for the function. One person should drive the vehicle while the other person observes the screen on the Tool. Do not attempt to drive and observe the scan tool at the same time. This is dangerous and puts your life and the lives of other motorists and pedestrians at risk.
-

7.6 Steering Angle Sensor (SAS) Service

SAS Calibration permanently stores the current steering wheel position as the straight-ahead position in the SAS EEPROM. Therefore, the front wheels and the steering wheel must be set exactly to the straight-ahead position before calibration. In addition, the VIN is also read from the instrument cluster and stored permanently in the SAS EEPROM. On successful completion of calibration, the SAS fault memory is automatically cleared.

Calibration must always be carried out after the following operations:

- Steering wheel replacement
- SAS replacement
- Any maintenance that involves opening the connector hub from the SAS to the column
- Any maintenance or repair work on the steering linkage, steering gear or other related mechanism
- Wheel alignment or wheel track adjustment

- Accident repairs where damage to the SAS or assembly, or any part of the steering system may have occurred.
-

 **NOTE**

1. Autel accepts no responsibility for any accident or injury arising from servicing the SAS system. When interpreting DTCs retrieved from the vehicle, always follow the manufacturer's recommendation for repair.
 2. All software screens shown in this manual are examples, and actual test screens may vary by test vehicle. Pay attention to the menu titles and onscreen instructions to make correct option selections.
 3. Before starting procedure, make sure the vehicle has an ESC button. Look for button on dash.
-

8 Data Manager

The Data Manager application allows you to store, print, and review the saved files, manage the workshop information, and customer information records, and keep test vehicle history records.

Selecting the Data Manager application opens the file system menu. There are nine main functions available.

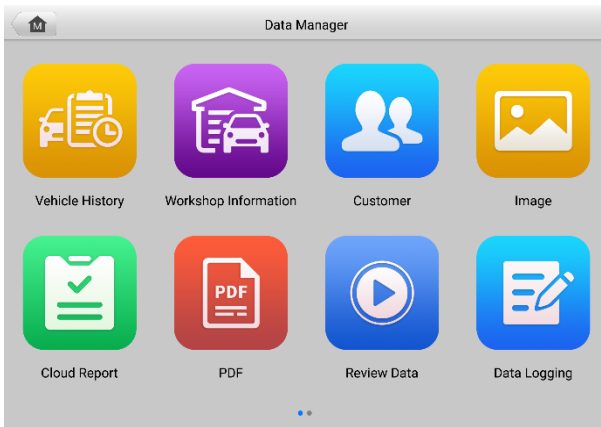







Figure 8-1 Data Manager Main Screen

The table below briefly describes each of the function buttons in the Data Manager application.

Table 8-1 Buttons in Data Manager

Button	Name	Description
	Vehicle History	Tap to review the diagnostics history record.

Button	Name	Description
	Workshop Information	Tap to edit the information of workshops.
	Customer	Tap to create new customer information.
	Image	Tap to review the screenshots.
	Cloud Report	Tap to review the saved reports and share cloud reports.
	PDF	Tap to review the reports stored as PDF files.
	Review Data	Tap to review the recorded data.
	Data Logging	Tap to review the communication data and ECU information of the vehicle. The saved data can be reported and sent to the technical center via the Internet.
	Uninstall Apps	Tap to uninstall applications.

8.1 Vehicle History

This function stores records of test vehicle history, including vehicle information and the retrieved DTCs from previous diagnostic sessions. Test information is summarized and displayed in an easy-to-read table listing. The Vehicle History also provides direct access to the previously tested vehicle and allows you to directly restart a diagnostic session without needing to perform auto or manual vehicle selection.

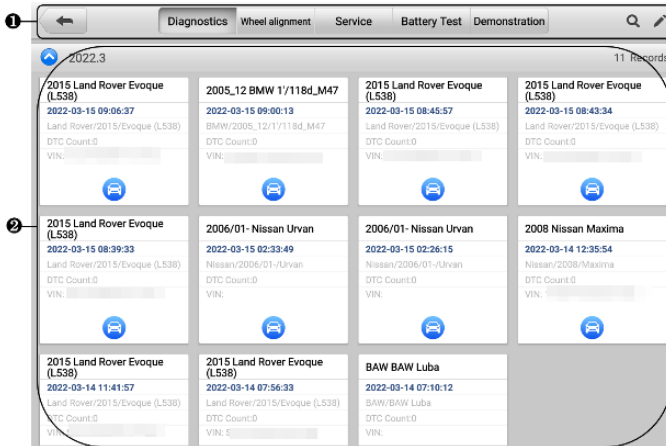

Figure 8-2 Vehicle History Screen

1. Top Toolbar Buttons — navigation and application controls.
 2. Main Section — displays all the vehicle history records.
- **To activate a test session for the recorded vehicle**
1. Tap **Data Manager** on the MaxiSys Job Menu.
 2. Select **Vehicle History** to open the screen. Tap the relevant application tab to select the test record. For example, tap **Diagnostics** to select diagnostics test records.
 3. Tap the **Diagnostics** icon at the bottom of the thumbnail of a vehicle record item.
 4. The Diagnostics screen of the vehicle displays and a new diagnostics session is activated. See [Diagnostics](#) to continue the diagnostics. Or,
 5. Select a vehicle thumbnail to open a record. A Historical Test record sheet displays. Review the recorded information of the test vehicle, and tap the **Diagnostics** button on the upper-right corner.

NOTE

The MaxiSys tablet must establish a stable connection to the VCI device to restart test sessions on the previously tested vehicles.

8.1.1 Historical Test Record

The Historical Test Record is a detailed data form of the vehicle, which includes general vehicle information, service record, customer information, and the diagnostic trouble codes retrieved from the previous test sessions. Technician Notes will also appear if present.

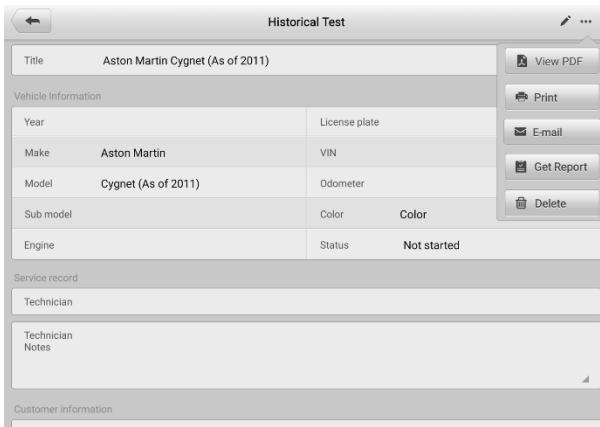

Figure 8-3 Historical Test Record Sheet

➤ **To edit the Historical Test record**

1. Tap **Data Manager** on the MaxiSys Job Menu.
2. Select **Vehicle History**.
3. Select the specific vehicle history record thumbnail from the main section. The Historical Test record will display.
4. Tap **Edit** (a pen icon) to start editing.
5. Tap each item to input information or attach files or images.

NOTE

The vehicle VIN, license number, and customer account information are correlated by default. Vehicle records will automatically be correlated using this vehicle and customer identification.

6. Tap **Add to Customer** to correlate the Historical Test record sheet to an existing customer account, or add a new associated account to be correlated with the test vehicle record. See *Customer* for more information.
7. Tap **Done** to save the updated record, or tap **Cancel** to exit without saving.

8.2 Workshop Information

The Workshop Information form allows you to edit, input, and save the detailed workshop information, such as shop name, address, phone number, and other remarks, which, when printing vehicle diagnostic reports and other associated test file, will display as the header of the printed documents.

The screenshot shows a mobile application interface for entering workshop information. At the top, there is a back arrow and the title 'Workshop information'. Below this, the form is organized into two main sections: 'Basic information' and 'More information'. The 'Basic information' section contains two logo upload buttons (each with a '+' icon) and several text input fields for 'Shop name', 'Tel', 'State', 'Fax', 'City', 'E-mail', 'Zip code', and 'Address'. The 'More information' section contains text input fields for 'Manager name', 'Manager title', 'Website', and 'Slogan'.

Figure 8-4 Workshop Information Sheet

- **To edit the Workshop Information sheet**
1. Tap the **Data Manager** application on the MaxiSys Job Menu.
 2. Select **Workshop Information**.
 3. Tap on each field to input the appropriate information.
 4. Tap **Done** to save the updated workshop information record, or tap **Cancel** to exit without saving.

8.3 Customer

The Customer function allows you to create and edit customer accounts. It helps you to save and organize all customer information accounts that are correlated with the associated test vehicle history records.

➤ **To create a customer account**

1. Tap the **Data Manager** application on the MaxiSys Job Menu.
2. Select **Customer**.
3. Tap the **Add a Customer** button. An empty information form displays; tap each field to input the appropriate information.

 **NOTE**

The items that must be filled are indicated as required fields.

4. Some customers may have more than one vehicle for service; you can always add new vehicle information to the account. Tap **Add New Vehicle Information**, and then fill in the vehicle information. Tap the  button to cancel.
5. Tap **Complete** to save the account, or tap **Cancel** to exit without saving.

➤ **To edit a customer account**

1. Tap **Data Manager** on the MaxiSys Job Menu.
2. Select **Customer**.
3. Select a customer account by tapping the corresponding name card. A Customer Information record displays.
4. Tap the **Edit** icon on the top toolbar to start editing.
5. Tap on the input field to edit or amend information, and enter the updated information.
6. Tap **Complete** to save the updated information, or tap **Cancel** to exit without saving.

➤ **To delete a customer account**

1. Tap **Data Manager** on the MaxiSys Job Menu.
2. Select **Customer**.
3. Tap the **Delete** icon on the right of a customer account. A message displays.
4. Tap **OK** to confirm the command, and the account is deleted, or tap **Cancel** to cancel the request.

8.4 Image

The Image section is a PNG database containing all captured screenshots.

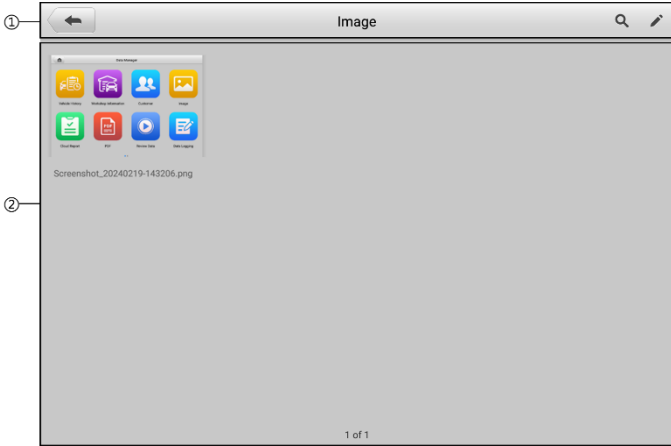





Figure 8-5 Image Database Screen

1. **Toolbar Buttons** — used to edit, print, or delete the image files. See [Table 8-2 Toolbar Buttons in PNG Database](#) for detailed information.
2. **Main Section** — displays the stored images.

Table 8-2 Toolbar Buttons in PNG Database

Button	Name	Description
	Back	Returns to the previous screen.
	Search	Tap to search the image by entering its stored time.
	Edit	Tap to display the editing toolbar to select, delete, print, or email the image(s).
	Cancel	Tap to close the editing toolbar or cancel file search.

Button	Name	Description
	Print	Tap to print the selected image.
	Delete	Tap to delete the selected image.
	Email	Tap to send the selected image to an email.

➤ **To edit/delete image(s)**

1. Select **Data Manager** from the MaxiSys Job Menu.
2. Select **Image** to access the PNG database.
3. Tap **Edit** on the top-right corner of the window. The editing screen displays.
4. Select the image(s) you want to edit by tapping the check box at the bottom-right corner of the image.
5. Tap the **Delete** icon to delete the selected images or delete all images. Tap the **Print** icon to print the selected image(s). Tap the **Email** icon to send the selected image(s) to an email.

8.5 Cloud Report

This section displays the saved reports, which can be transferred to the Autel cloud platform once a stable network connection is established. These reports can then be viewed or shared with others. See [Report Settings](#) and [Diagnostics Report Saving, Viewing, and Sharing](#) for further details.

8.6 PDF Files

The PDF files designated for local viewing are displayed in this section. Enter the PDF database and select a file to access the saved information.

This section uses the standard Adobe Reader application for file viewing and editing. Please refer to the associated Adobe Reader manual for more detailed instructions.

8.7 Review Data

The Review Data section allows you to play back the recorded data frames of live data streams.

On the Review Data main screen, select a record file to play back.

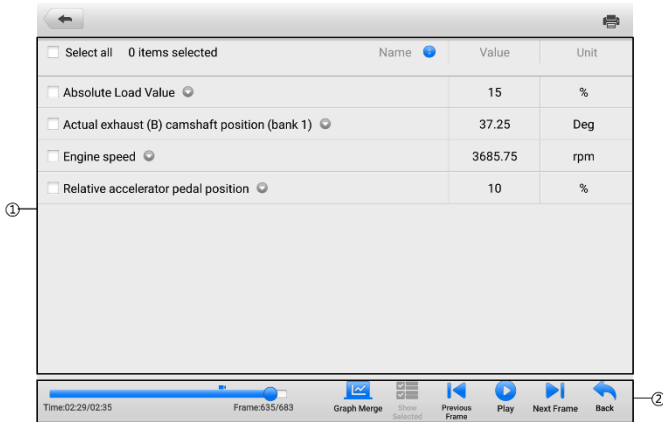

Figure 8-6 Data Playback Screen

1. Main Section — displays the recorded data frames.
2. Navigation Toolbar — allows you to manipulate data playback.

Use the Navigation Toolbar buttons to play back the record data from frame to frame.

Tap **Back** to exit data playback.

8.8 Data Logging

The Data Logging section allows you to launch Support platform directly to view all records of all feedback or no feedback data loggings on the diagnostic system. For more details, see [Data Logging](#).

8.9 Uninstall Apps

This section allows you to manage the software applications installed on the MaxiSys diagnostics system. Selecting this section opens a managing screen, on which you can check all available vehicle diagnostic applications.

Select the vehicle software you want to delete by tapping on the vehicle manufacturer icon. The selected item will display a blue mark at the upper-right corner. Tap the **Delete** button on the top toolbar to delete the software from the system database.

9 Battery Test

The Battery Test application allows the user to perform in-vehicle battery test and out-vehicle battery test functions when the BT506 battery tester is connected to the MaxiSys tablet and a battery. The BT506 battery tester enables technicians to view the health status of the vehicle's battery and electrical system.

NOTE

The BT506 battery tester needs to be purchased separately.

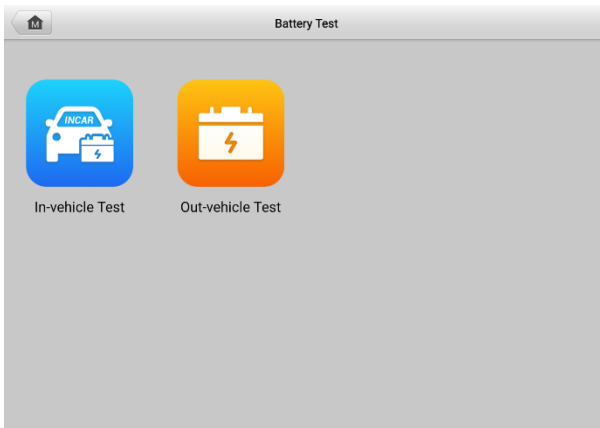

Figure 9-1 *Battery Test Screen*

9.1 MaxiBAS BT506 Battery Tester

9.1.1 Function Description

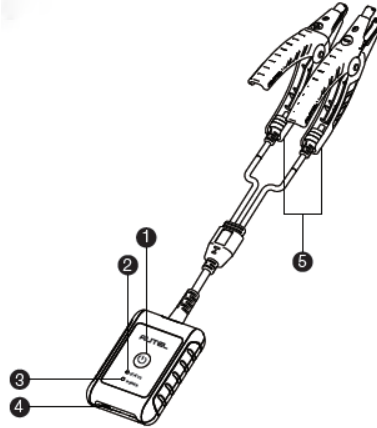

Figure 9-2 MaxiBAS BT506 Tester

- 1. Power Button
- 2. Status LED
- 3. Power LED
- 4. USB Port
- 5. Battery Clamp Cable

Table 9-1 LED Description

LED	Color	Description
Status LED	Flashing Green	The tester is communicating via USB cable.
	Flashing Blue	The tester is communicating via Bluetooth.
	Flashing Red	Battery clamps are connected to the wrong battery terminals.

LED	Color	Description
Power LED	Solid Green	The tester is powered on and the battery is sufficiently charged.
	Flashing Green	The tester is charging. (Turns solid green when battery is fully charged.)
	Solid Red	The device is in boot mode.
	Flashing Red	The battery level is low. Please charge.

9.1.2 Power Sources

The MaxiBAS BT506 tester can receive power from the following sources:

- Internal Battery Pack
- AC/DC Power Supply

! IMPORTANT

Do not charge the tester when the temperature is below 0 °C (32 °F) or above 45 °C (113 °F).

9.1.2.1 Internal Battery Pack

The MaxiBAS BT506 battery tester can be powered with the internal rechargeable battery.

9.1.2.2 AC/DC Power Supply — Using Power Adapter

The MaxiBAS BT506 battery tester can be powered from an electrical outlet using the AC/DC power adapter. The AC/DC power supply also charges the internal battery pack.

9.1.3 Technical Specifications

Table 9-2 Technical specifications

Item	Description
Connectivity	<ul style="list-style-type: none"> ● USB 2.0, Type C ● Bluetooth 4.2
Input Voltage	5 V DC
Working Current	< 150 mA at 12 V DC

Item	Description
Internal Battery	3.7 V/800 mAh Lithium-ion Polymer battery
CCA Range	100 to 2000 A
Voltage Range	1.5 to 16 V
Working Temp.	- 10 °C to 50 °C (14 °F to 122 °F)
Storage Temp.	- 20 °C to 60 °C (- 4 °F to 140 °F)
Dimension (L x W x H)	107 mm (4.21") x 75 mm (2.95") x 26 mm (1.02") (clamp cable not included)
Weight	320 g (0.7 lbs.)

9.2 Test Preparation

9.2.1 Inspect the Battery

Before starting a test, inspect the battery for:

- Cracking, buckling or leaking. If you see any of these defects, replace the battery.
- Corroded, loosen or damaged cables and connections. Repair or replace as needed.
- Corrosion on the battery terminals, and dirt or acid on the case top. Clean the case and terminals using a wire brush and a mixture of water and baking soda.

9.2.2 Connect the Battery Tester

➤ To pair with the MaxiSys tablet

1. Turn on both the MaxiSys tablet and the BT506 battery tester. Ensure that the units are sufficiently charged before you begin.
2. Enable Bluetooth on the tablet by tapping **VCI Manager > BAS BT**. Tap **Scan** at the top-right corner. The device will start to search for available pairing units.
3. Depending on the type of battery tester, the device name may display as "Maxi" suffixed with a serial number. Select the appropriate device for pairing.
4. When paired successfully, the connection status will read "Connected."

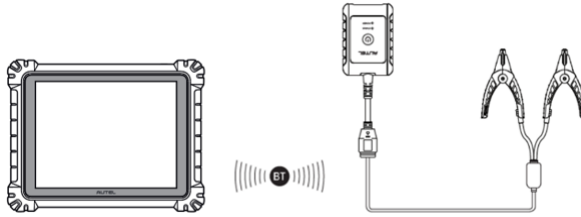

Figure 9-3 Battery Tester Connection Example 1

➤ **To connect to a battery**

1. Connect the red clamp to the positive (+) terminal of the battery.
2. Connect the black clamp to the negative (-) terminal of the battery.

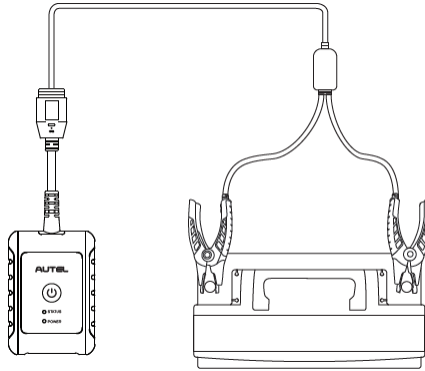

Figure 9-4 Battery Tester Connection Example 2

9.3 In-vehicle Test

The In-vehicle Test is used for testing batteries that are installed in a vehicle. An in-vehicle test includes the Battery Test, Starter Test, and Generator Test. These tests help determine the health of the battery, the starter, and the generator.

! IMPORTANT

A disclaimer will appear when first accessing any function on the Home screen. Please read the end-user agreement and tap **Accept** to continue. If you tap **Decline**, you will not be able to use the features properly.

Prior to testing any battery, ensure that the battery tester is paired with the tablet via Bluetooth and connected properly to a battery.

➤ **To start the in-vehicle test**

1. Tap **Battery Test** on the MaxiSys Job Menu. Select **In-vehicle Test**.
2. Confirm the vehicle information on the left side of the screen. Make sure the VIN is entered.
3. Confirm your battery information, including voltage, type, standard, and capacity. Tap **Next** to continue in-vehicle test functions.

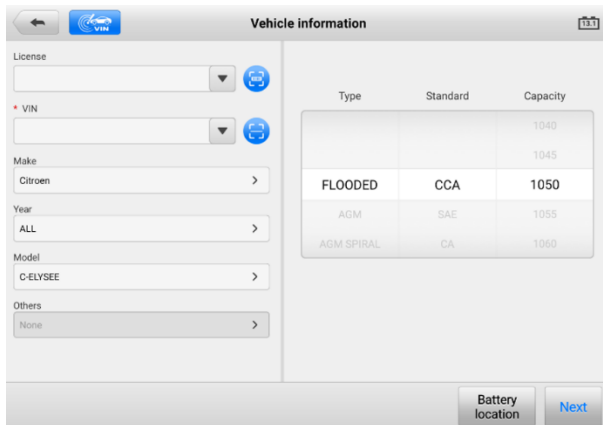



Figure 9-5 Battery information Screen



NOTE

In the Settings application, the Battery Test option allows you to change the requirement for entering the VIN information. If the setting is enabled, supplying the VIN is no longer mandatory.

Refer to the table below for a list of buttons that may appear when accessing the functions:

Table 9-3 Top Toolbar Buttons

Button	Name	Description
	Battery Connection	The value on the icon indicates the real-time voltage of the tested battery. In the battery test, the button will turn green if the battery is good; otherwise, it will turn red.
	Next	Tap to proceed.

Button	Name	Description
	Home	Returns to the battery test main screen.
	Back	Returns to the previous screen.
	Exit	Returns to the Job Menu.

9.3.1 Battery Test

1. Follow the on-screen instructions. Check the boxes once all required tasks are completed, and tap **Start Testing**.

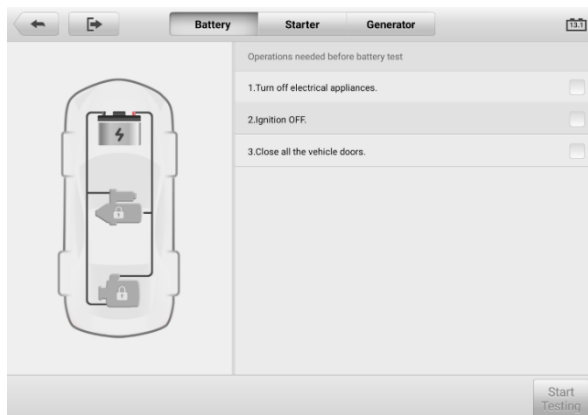

Figure 9-6 Battery Screen

2. Wait until the test is completed. The test results will be displayed on the tool.

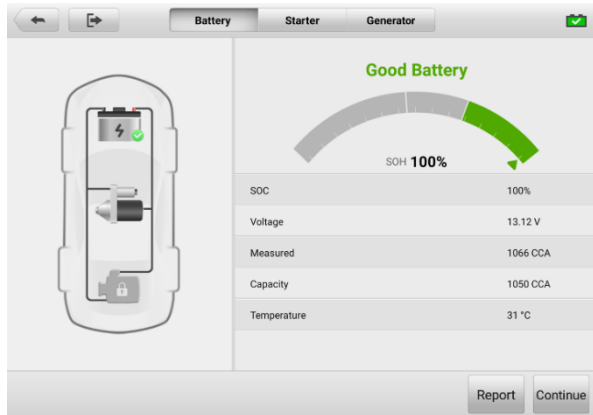

Figure 9-7 Battery Test Results Screen

Table 9-4 Test Results

Result	Description
Good Battery	Battery is good.
Good & Recharge	Battery is good but insufficiently charged. Recharge the battery.
Charge & Retest	Battery requires charge to determine its condition.
Bad Cell	Replace the battery.
Replace Battery	Replace the battery.

NOTE
Please always complete the battery test before you proceed to the starter and generator tests.

9.3.2 Starter Test

Follow the on-screen instructions to complete the test. Start the engine and let it idle. The test results will appear as follows:

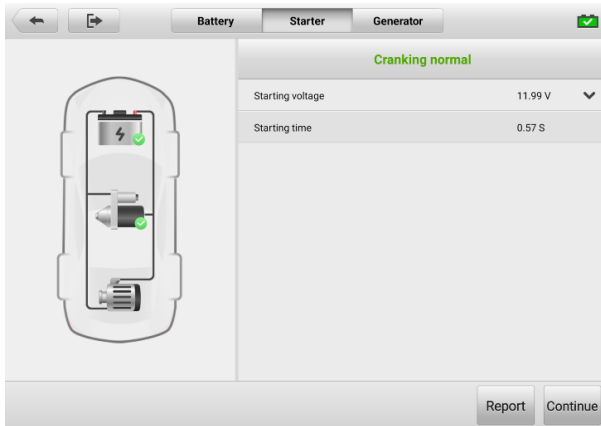

Figure 9-8 Starter Test Result Screen

Table 9-5 Starter Test Results

Result	Description
Cranking Normal	The starter is good.
Current Too Low	Low momentary discharge capacity.
Voltage Too Low	Low battery storage capacity.
Not Started	The starter is not detected for starting.

9.3.3 Generator Test

Follow the on-screen instructions to complete the test. The test results will appear as follows:

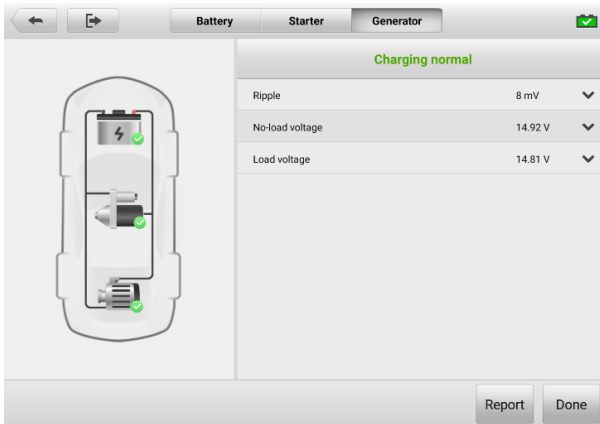

Figure 9-9 Generator Test Results Screen

Table 9-6 Generator Test Results

Result	Description
Charging Normal	The generator is functioning normally.
Output Too Low	<ul style="list-style-type: none"> The belt linking the starter and the generator is loose; The cable linking the starter and battery is loose or corroded.
Output Too High	<ul style="list-style-type: none"> The generator is not properly connected to the ground; The voltage adjuster is broken and needs replacement.
Ripple Too Large	The commutation diode is broken.
No Output	<ul style="list-style-type: none"> The cable is loose; Some vehicles with power management systems do not provide path for charging due to the sufficient load capacity of the battery; The generator or the voltage adjuster is broken and needs replacement.

9.4 Out-vehicle Test

Out-vehicle Test is used to test the condition of batteries that are not connected to a vehicle. This function aims to check the health status of the battery only.

9.4.1 Test Procedure

➤ **To start the out-vehicle test**

1. Connect the tester clamps to the battery terminals.
2. Tap **Battery Test** on the MaxiSys Job Menu. Select **Out-vehicle Test**.
3. Select the appropriate battery type, rating standard, and CCA value. Tap **Start Testing** to start the test.

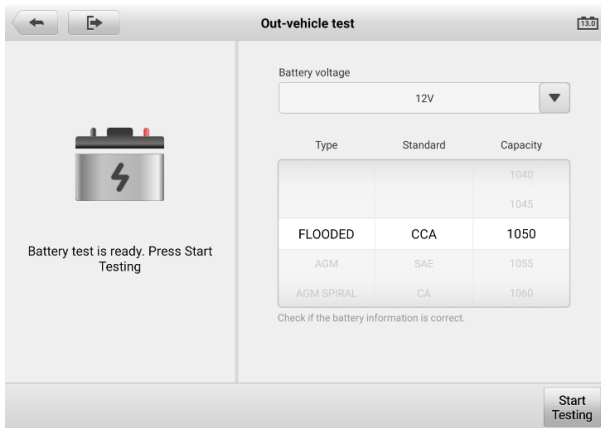

Figure 9-10 Out-vehicle Test Screen

4. The test results will display in a few seconds.

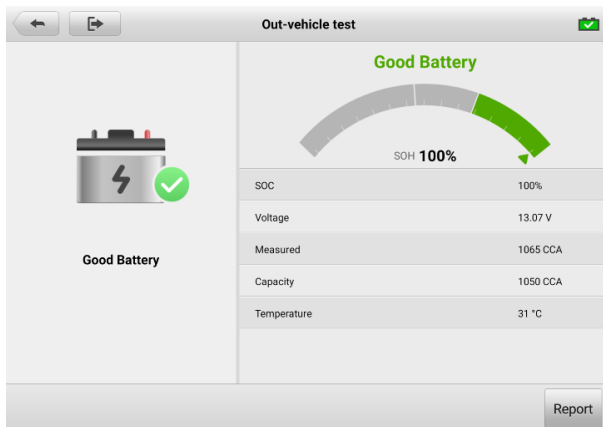

Figure 9-11 Out-vehicle Test Results Screen

9.4.2 Test Results

Table 9-7 Out-Vehicle Test Results

Result	Description
Good Battery	Battery meets required standards.
Good & Recharge	Battery is good, but low on charge. Fully charge the battery. Check for causes of low charge.
Charge & Retest	Battery requires charge to determine its condition.
Replace Battery	Battery fails to meet industry-accepted standards.
Bad Cell	Battery fails to meet industry-accepted standards.

10 Settings

Access the Settings menu to adjust default setting and view information about the MaxiSys system. The following options are available for the MaxiSys system settings:

- Unit
- Language
- Printing Settings
- Report Settings
- Push Notification
- Auto Update
- ADAS & Aligner Settings
- Vehicle List
- AutoVID Setup
- Country/Region Code
- System Settings
- About

10.1 Unit

This option allows you to change the measurement unit for the diagnostic system.

- **To adjust the unit setting**
 1. Tap the **Settings** application on the MaxiSys Job Menu.
 2. Tap the **Unit** option on the left column.
 3. Select the appropriate measurement unit. A check mark will display to the right of the selected unit.
 4. Tap the **Home** button on the top-left corner to return to the MaxiSys Job Menu, or select another settings option for system setup.

10.2 Language

This option allows you to adjust the display language for the MaxiSys system.

➤ **To adjust the language setting**

1. Tap the **Settings** application on the MaxiSys Job Menu.
2. Tap the **Language** option on the left column.
3. Select the appropriate language. A check mark will display to the right of the selected language.
4. Tap the **Home** button on the top-left corner to return to the MaxiSys Job Menu, or select another settings option for system setup.

10.3 Print Settings

This option allows you to print from the tablet to a network printer via a computer.

➤ **To setup the printer connection**

1. Tap **Settings** on the MaxiSys Job Menu.
2. Tap **Printing Settings** on the left column.
3. Tap **Print via PC-link** or **Print via Wi-Fi** to activate the printing function, which enables the device to send files to the printer through the PC via Wi-Fi or Ethernet connection.
4. Tap the **Home** button on the top-left corner to return to the MaxiSys Job Menu, or select another settings option for system setup.

10.3.1 Printing Operations

➤ **To install the MaxiSys Printer driver**

1. Download **Maxi PC Suite** from www.autel.com > Support > Downloads > Autel Update Tools, and install it to a Windows-based PC.
2. Double click on **Setup.exe**.
3. Select the installation language and the wizard will load.
4. Follow the instructions on the screen and Click on **Next** to continue.
5. Click **Install** and the printer driver program will be installed onto the computer.
6. Click **Finish** to complete the installation.

 **NOTE**

The MaxiSys printer runs automatically after the installation. The PC, printer and the tablet must be connected to the same network.

This section describes how to receive file from the MaxiSys tablet and perform printing through the PC.

 **NOTE**

1. Make sure the tablet is connected to the same network with your computer, either via Wi-Fi or LAN, before printing.
 2. Make sure the computer installed with the Printing Services program is connected to a printer.
-

➤ **To perform printing through the computer**

1. Ensure the tablet is connected to the computer network, either via Wi-Fi or LAN, before printing.
 2. Run the **PC Link** program on the computer.
 3. Select the **MaxiSys Printer** tab.
 4. Tap the **Print** button in the tablet top toolbar. A document will be sent to the computer.
 - If the **Auto Print** option in the MaxiSys Printer is selected, the MaxiSys Printer will print the received document automatically.
 - If the **Auto Print** option is not selected, click **Open PDF File** button to view files. Select the file(s) to print and click **Print**.
-

 **NOTE**

To confirm that the printer is functioning normally, you can click **Test Print** in the PC Link program to test.

10.4 Report Settings

Toggle the **ON/OFF** button to enable/disable Report Upload to Cloud function. If the button displays blue, it indicates the Report Upload to Cloud function is enabled. If the button displays gray, it indicates the Report Upload to Cloud function is disabled.

10.5 Push Notification

This option allows you to manage notifications. The Notification Preference is turned on by default and cannot be turned off by users so that certain system notifications such as system security warnings won't be blocked. Internet access is required for receiving on-line messages.

➤ **To manage other notifications**

1. Tap **Settings** on the MaxiSys Job Menu.
2. Tap **Push Notifications** on the left column.
3. Tap the ▼ button on the right to open a drop-down list.
4. There are four options: Enable all notifications, Limit to 3 notifications or less per week, Limit to 1 notification per week, and Disable all notifications. Select whichever you want.
5. Tap **Home** on the top-left corner to return to the MaxiSys Job Menu. Or select another settings option for the system setup.

🔗 **NOTE**

3. Notifications will display on the screen. Slide the screen from top to check the received messages. If the message list covers more than one screen, slide the list up or down to view them.
 4. Tapping a specific message launches the corresponding application. For example, if you tap on an Update notification, the Update application will be launched.
-

10.6 Auto Update

The Auto Update allows the tool to automatically update the OS, the MaxiSys system, and the vehicle coverage software. Each can be configured to update automatically at a specified time. Tap the **ON/OFF** button to enable/disable the desired automatic update time.

➤ **To set auto system or vehicle update**

1. Tap the **Settings** application on the MaxiSys Job Menu.
2. Tap the **Auto Update** option on the left column. The three auto update items will display on the right of the screen.
3. Select the update type to schedule. Toggle the button to **ON**.
4. Tap on the time to set the time of the day for updating. If the update time is set and the device is connected to the Internet, the selected software will be automatically updated at the configured time.

10.7 ADAS & Aligner Settings

This section allows you to check if your tablet is connected to the calibration frame. Depending on the paired calibration frame, an array of configurations can be performed. These include common settings, calibration frame connection, network configuration, updates, maintenance & service, as well as wheel alignment software settings.

10.7.1 Common Settings

Within the common settings, you are allowed to modify the unit of measurement and select the appropriate tools required for wheel alignment & ADAS calibration procedures.

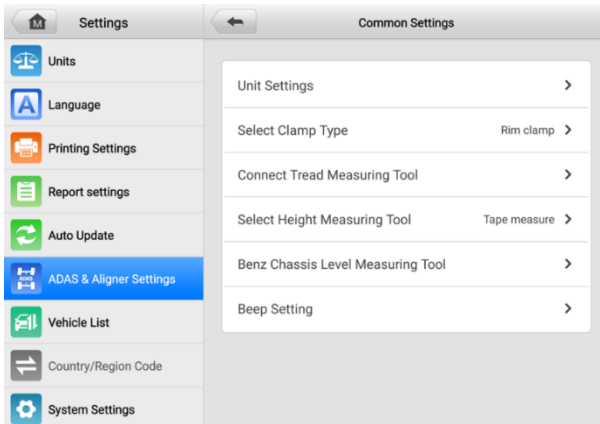

Figure 10-1 Common Settings Screen

10.7.1.1 Unit Settings

This option allows you to change the measurement unit during wheel alignment & ADAS calibration procedures.

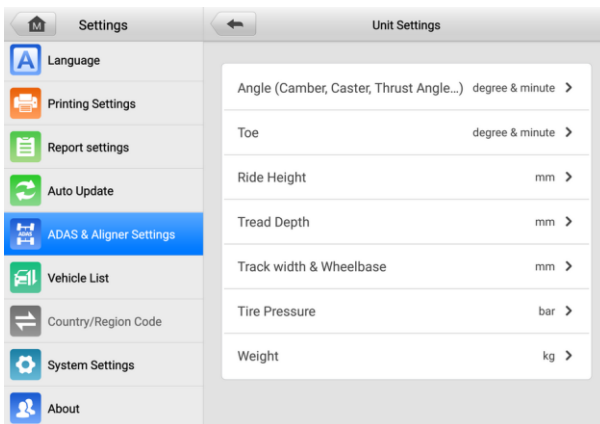

Figure 10-2 Unit Settings Screen

10.7.1.2 Select Clamp Type

Select the clamp type (rim clamp or tire clamp) to perform compensation:

- a) Upon selecting the **Rim Clamp** option, the tablet will guide you through the process of performing the wheel alignment or ADAS calibration function using rim clamps.
- b) Upon selecting the **Tire Clamp** option, the tablet will guide you through the process of performing the wheel alignment or ADAS calibration function using rim clamps.

 **NOTE**

Rim clamp is selected by default.

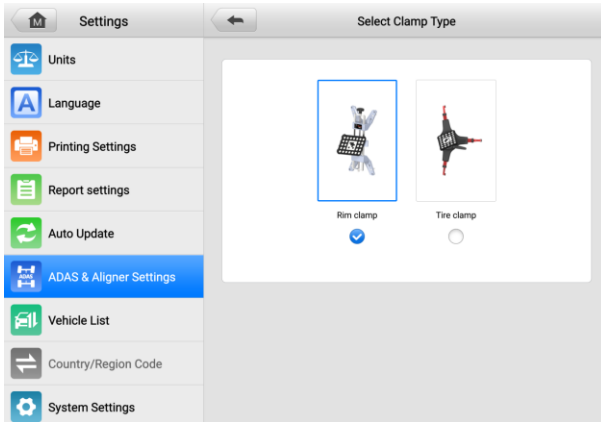

Figure 10-3 Select Clamp Type

10.7.1.3 Connect Tread Measuring Tool

This setting enables you to connect a TBE device for tread depth & pressure measurement. The specific operations on how to connect a TBE device can be found in the previous section. For details, refer to [Tread Depth & Pressure Inspection](#).

10.7.1.4 Select Height Measuring Tool

This section enables you to select the tool for ride height measurement. Two options are available: Tape measure and Ride height target.

- a) When you select **Tape Measure**, you need to measure the ride height as shown in the screen guides, and enter the values into the corresponding box after measurement. For more details, refer to [Ride Height Measurement](#).
- b) When you select **Ride Height Target**, the crossbar height will automatically adjust and search for the target in the Ride Height Measurement screen. Subsequently, the

ride height will be calculated and automatically displayed in the corresponding input box. For more details, refer to [Ride Height Measurement](#).

NOTE

Tape measure is selected by default.

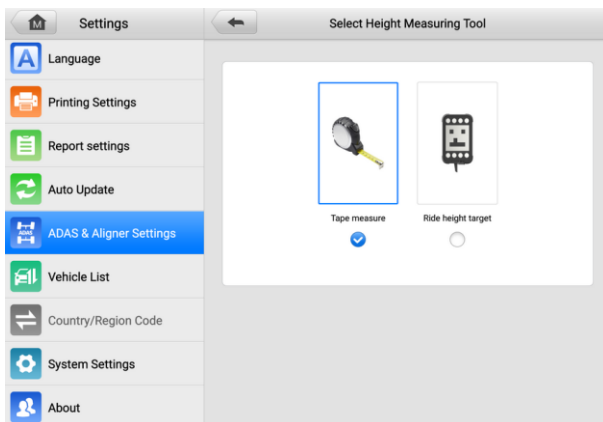

Figure 10-4 Select Height Measuring Tool

10.7.1.5 Benz Chassis Level Measuring Tool

Currently, users are required to purchase a specific measuring tool to gauge the chassis level of Mercedes-Benz vehicles.

10.7.1.6 Beep Setting

This setting allows you to enable or disable beeps when performing roll compensation, lifting compensation, or caster/SAI measurements.

- a) When the ON/OFF button is switched to the **ON** position, the beep is enabled. There will be a beep sound during the rolling compensation, the lifting compensation, or the Caster/SAI measurement procedures.
- b) When the ON/OFF button is switched to the **OFF** position, the beep is disabled. There will be no beep sound during the rolling compensation, the lifting compensation, or the Caster/SAI measurement procedures.

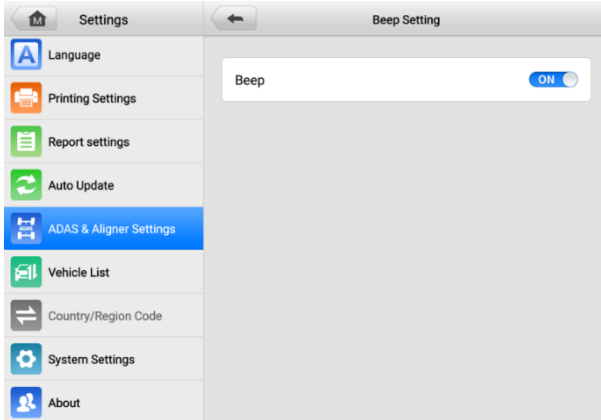

Figure 10-5 *Beep Setting Screen*

10.7.2 Calibration Frame Connection

Once the wheel alignment & ADAS calibration software have been successfully activated on your MaxiSys tablet, the tablet is now primed for connection to a calibration frame.

The communication between the MaxiSys tablet and the IA900WA is established via Wi-Fi. Follow the steps below to connect the IA900WA to the MaxiSys tablet.

➤ To connect IA900WA to MaxiSys tablet

1. Tap **Settings > ADAS & Aligner Settings**, then select the **Calibration Frame Connection** option to display the Calibration Frame Connection screen.

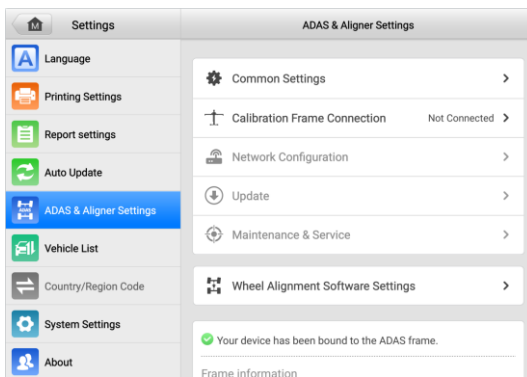

Figure 10-6 *Connecting IA900WA to MaxiSys Tablet 1*

2. Swipe the Wi-Fi toggle switch to enable calibration frame Wi-Fi. The tablet will search for available units. The Wi-Fi name of the IA900WA calibration frame will be “ADAS,” suffixed with a serial number. Tap the appropriate unit to connect. When a connection is established, the connection status reads “Connected.”

NOTE

It may take up to 30 seconds to connect the calibration frame to a MaxiSys tablet. Please wait patiently.

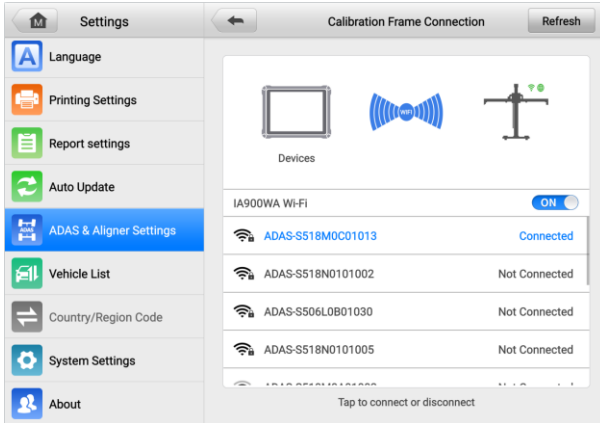

Figure 10-7 Connecting IA900WA to MaxiSys Tablet 2

3. Tap the **Back** button on the top of the screen to return to the Settings Menu.

10.7.3 Network Configuration

After connecting the IA900WA to the MaxiSys tablet via Wi-Fi, you will need to configure the ADAS & Aligner network by doing the following steps.

➤ **To configure ADAS & Aligner network**

1. Tap **Settings > ADAS & Aligner Settings**, then select the **Network Configuration** option to display the Network Configuration screen.

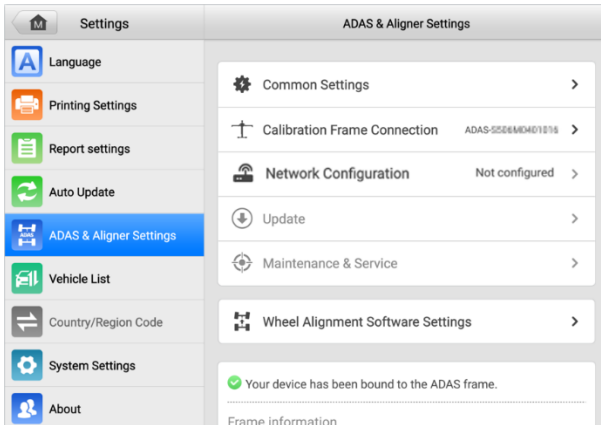

Figure 10-8 ADAS & Aligner Network Configuration 1

2. Tap the drop-down button to select your Wi-Fi network, then enter the password. If you are unable to find your Wi-Fi network in the list, check the Wi-Fi settings and ensure that your network is active and within range, then tap the **Refresh** button to search for available Wi-Fi networks again. Tap **Connect** once you have confirmed.

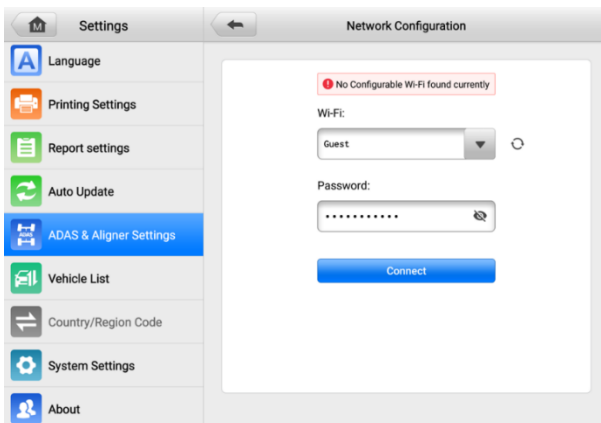

Figure 10-9 ADAS & Aligner Network Configuration 2

3. Tap the **Back** button on the top of the screen to return to the Settings Menu.

10.7.4 Update

The section enables you to download the latest version of the wheel alignment & ADAS software.

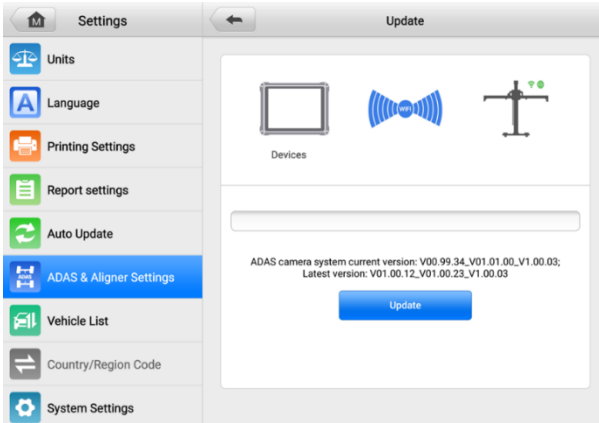

Figure 10-10 Update Screen

10.7.5 Maintenance & Service

If you notice an inaccuracy during the wheel alignment and ADAS calibration process, select the relevant item from this section for recalibration.

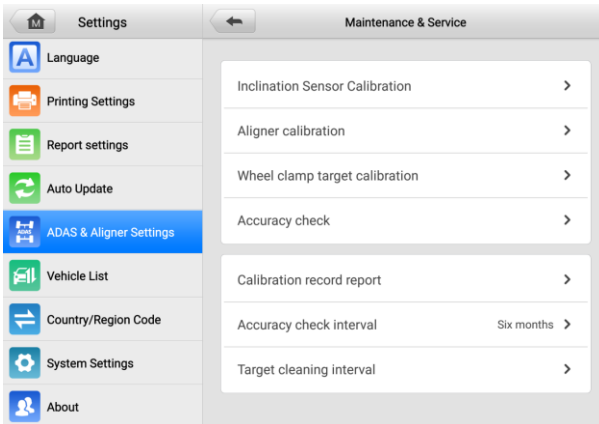

Figure 10-11 Maintenance & Service Screen

10.7.5.1 Inclination Sensor Calibration

The inclination sensor needs to be calibrated when:

1. Using the IA900WA for the first time.
2. The camera has been disassembled.

➤ **To calibrate inclination sensor**

1. Select **Settings** from the MaxiSys Job Menu.
2. Tap **ADAS & Aligner Settings** on the left of the screen.
3. Tap **Maintenance & Service**. Select **Inclination Sensor Calibration**.

 **NOTE**

Ensure the calibration frame Wi-Fi is connected, or the maintenance & service function cannot be activated.

4. As shown in the screen guide, place the calibration frame on a level ground and depress the pedal to fix the calibration frame. Rotate the buttons A and B to center the pitch and roll level bubbles.

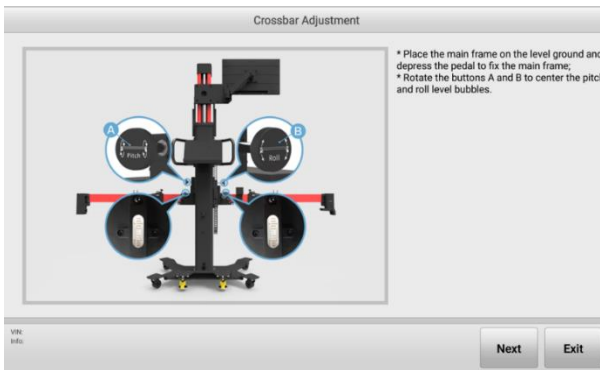

Figure 10-12 Crossbar Adjustment 1

5. Tap **Next**. The inclination sensor will collect data and automatically enter the next screen after the collection is completed. Rotate the button B clockwise to roll the crossbar to the left limit.

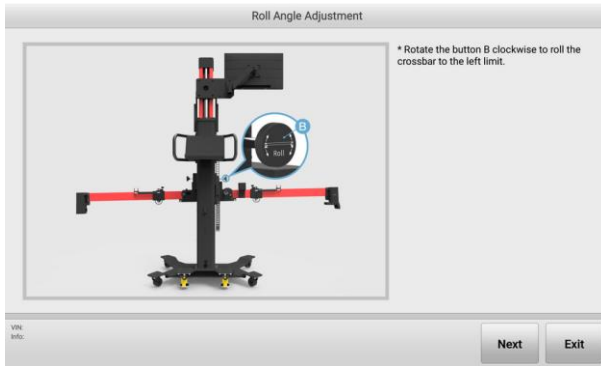

Figure 10-13 Roll Angle Adjustment 1

6. Tap **Next**. The inclination sensor will collect data and automatically enter the next screen after the collection is completed. Follow the on-screen guides. Rotate the button B counterclockwise to roll the crossbar to the right.

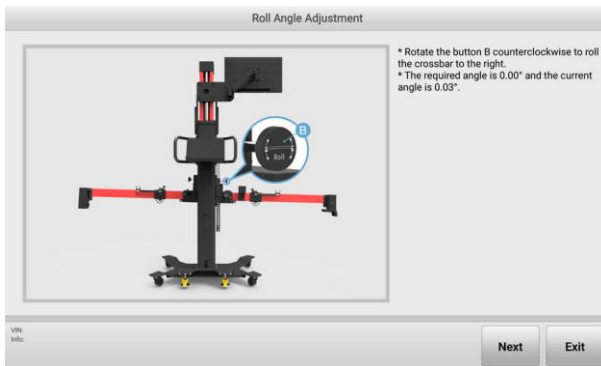

Figure 10-14 Roll Angle Adjustment 2

7. When the current angle is adjusted to the required angle, tap **Next**. The inclination sensor will collect data, and will automatically enter the following screen after the collection is completed. And follow the on-screen guide. Rotate the button B to center the roll level bubble.

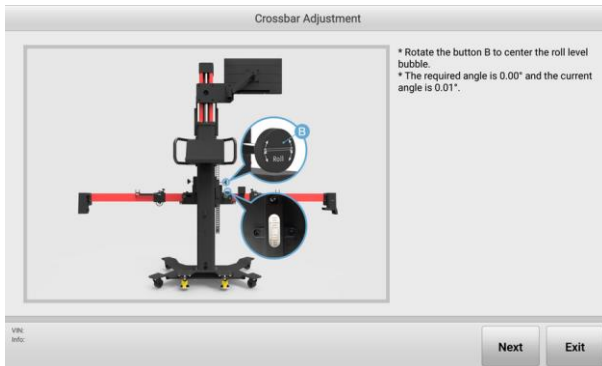



Figure 10-15 Crossbar Adjustment 2

8. After the operation is completed by following the prompts on the screen, the calibration results will appear. If the screen displays , it indicates that the calibration is successful; if the screen displays , it indicates the calibration has failed and needs to be recalibrated.

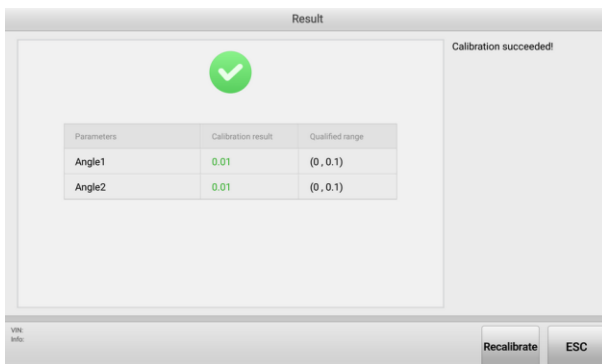

Figure 10-16 Calibration Result Screen

10.7.5.2 Aligner Calibration

The aligner needs to be calibrated when:

1. The camera has been disassembled.
2. Accuracy check has failed.

NOTE

To perform Aligner calibration, a professional calibration tool (AUTEL-CSC0500/10) is required. You can contact your local dealer or manufacturer for calibration.

➤ **To calibrate aligner**

1. Select **Settings** from the MaxiSys Job Menu.
2. Tap **ADAS & Aligner Settings** on the left of the screen.
3. Tap **Maintenance & Service**. Select **Aligner calibration**.

 **NOTE**

Ensure the calibration frame Wi-Fi is connected, or the maintenance & service function cannot be activated.

4. Place the calibration bar about 2.2 m in front of the calibration frame. Install the front wheel targets on the calibration bar, and align the location pin with the locating hole. Then tighten the nut.

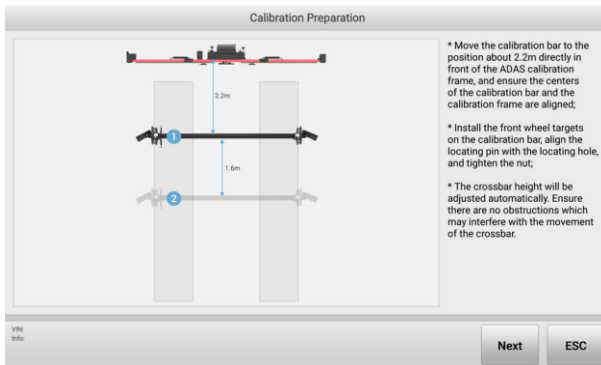

Figure 10-17 Aligner Calibration Preparation

5. Tap **Next**. The crossbar height will be adjusted automatically and search the target, and will enter the following screen. Follow the on-screen guide. Move the calibration bar so that the values of 'Offset', 'L-Distance', and 'Distance Diff' are displayed in green.



Figure 10-18 Aligner Calibration 1



Figure 10-19 Aligner Calibration 2

6. Then tap **Next** to enter the following screen. Rotate the calibration bar according to the screen prompts to collect data. When the arrows and the indicated block images turn green, stop rotating the crossbar.

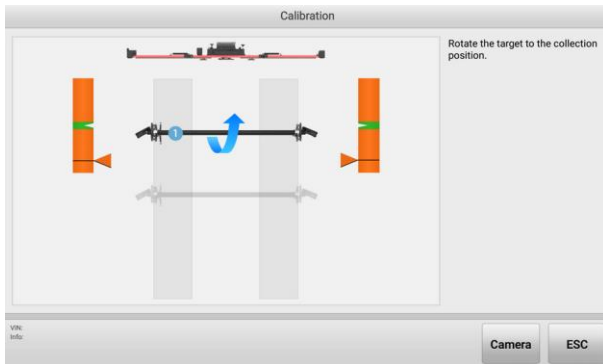

Figure 10-20 Calibration Screen 1

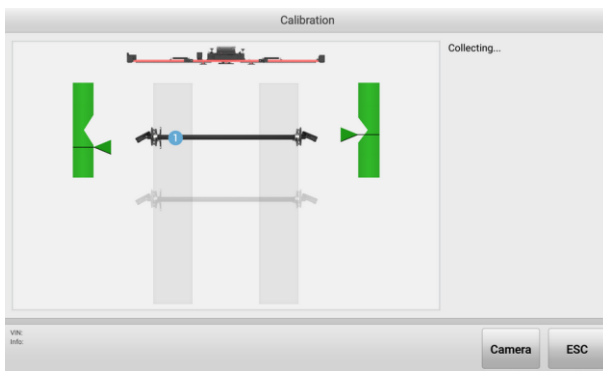



Figure 10-21 Calibration Screen 2

7. After collecting data, the calibration result screen will display, as shown in the figure below. If the screen displays , it indicates that the calibration is successful. If the screen displays , it indicates the calibration has failed, and you need to tap **Recalibrate** again.

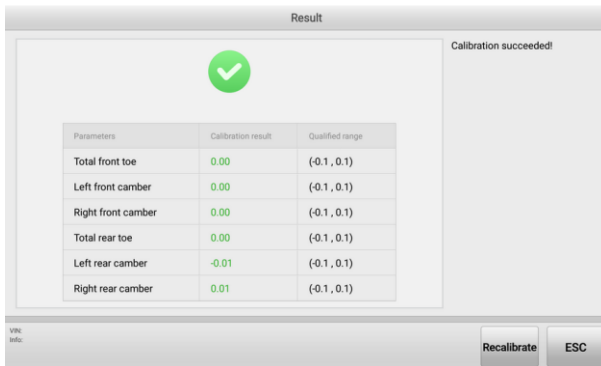

Figure 10-22 Calibration Result

8. Then remove the front wheel targets from the calibration bar and install the rear wheel targets on the calibration bar. And place the calibration bar about 5.4 m in front of the calibration frame. Complete the calibration steps as shown in the screen guides. Since the calibration steps are roughly the same and clearly illustrated on the tablet, it will not be repeated here.

10.7.5.3 Wheel Clamp Target Calibration

When the matching wheel clamp (rim clamp/tire clamp) or the target has been replaced, the newly assembled wheel clamp (rim clamp/tire clamp) and target need to be recalibrated.

NOTE

As mentioned before, the illustrations involving clamps in this manual are based on the use of rim clamps. Here we select rim clamp and target for calibration illustration. The procedures for tire clamp and target calibration are roughly the same, so it will not be repeated here.

A. Using a Calibration Bar

➤ To calibrate wheel clamp (rim clamp) and target by using calibration bar

1. Prepare a professional calibration tool — calibration bar AUTEK-CSC0500/10.
2. Select **Settings** from the MaxiSys Job Menu.
3. Tap **ADAS & Aligner Settings** on the left of the screen.
4. Tap **Maintenance & Service**, then select **Wheel clamp target calibration**.
5. Select **Wheel clamp target calibration — with calibration bar**. Read the notes and tap **OK**.

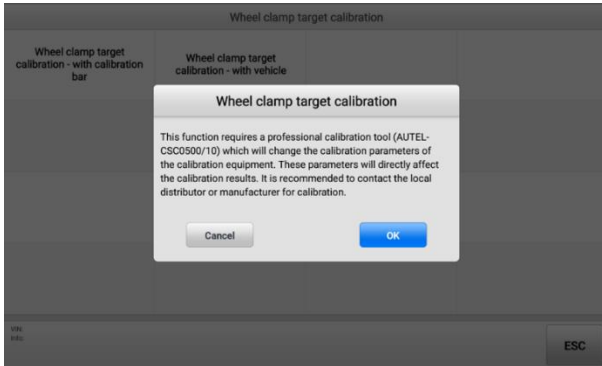

Figure 10-23 Select Calibration Method

6. Select the left front wheel clamp (rim clamp) installed with the target as an example.

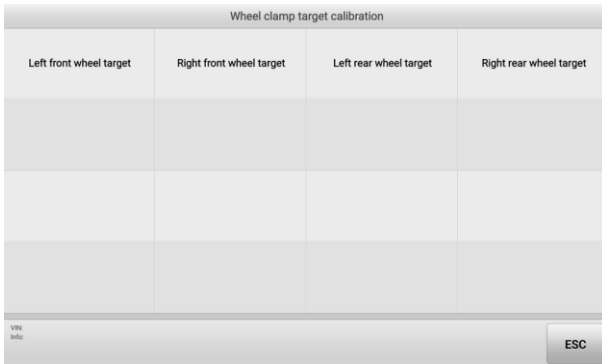

Figure 10-24 Select Target for Calibration

7. The tablet will automatically display the calibration preparations after you select the rim clamp and the target needed for calibration. Follow the on-screen guides. Move the calibration bar to the position about 2.2 m directly in front of the IA900WA calibration frame, and ensure the centers of the calibration bar and the calibration frame are aligned. Then install the left front wheel clamp (rim clamp) and the left front target on the calibration bar, and align the locating pin with the locating hole. Tighten the nut.

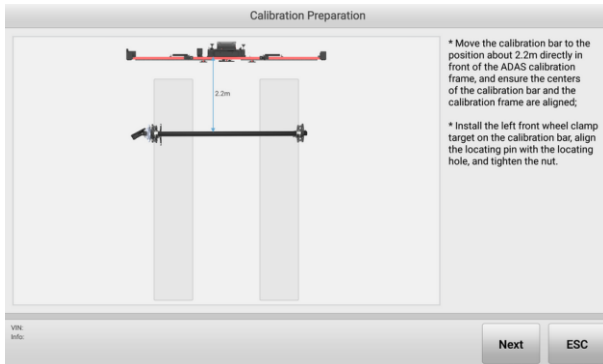

Figure 10-25 Calibration Preparation (Using a Calibration Bar)

8. When the steps above are completed, tap **Next** to continue. If the distance is not within the required range (2000 to 2400 mm), the tablet will prompt you to adjust it to the required range. In this case, you need to move the calibration bar to adjust the distance until the required range is reached.

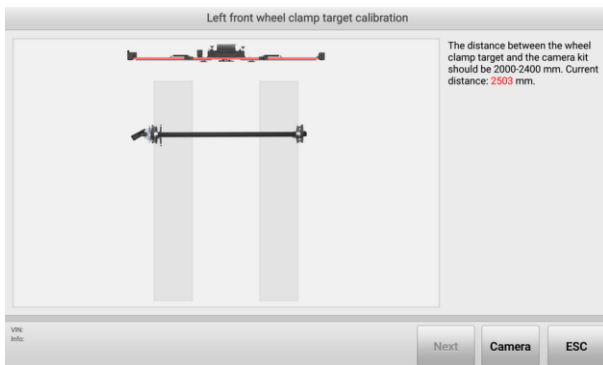

Figure 10-26 Start Calibration (Using a Calibration Bar) 1

9. Tap **Next** when the distance is adjusted to the required range. The tablet will prompt you that everything is ready for the next steps.

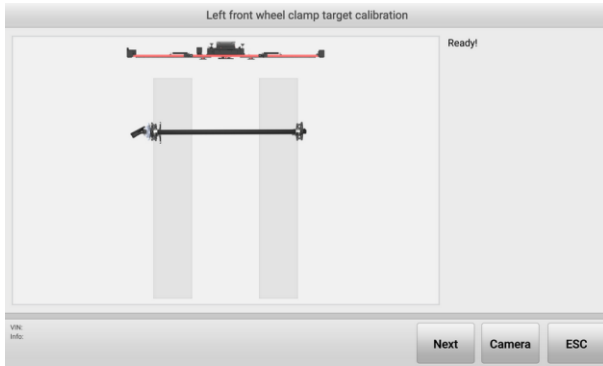

Figure 10-27 Start Calibration (Using a Calibration Bar) 2

10. Follow the on-screen guides to rotate the calibration bar so that the target is in the collection position.

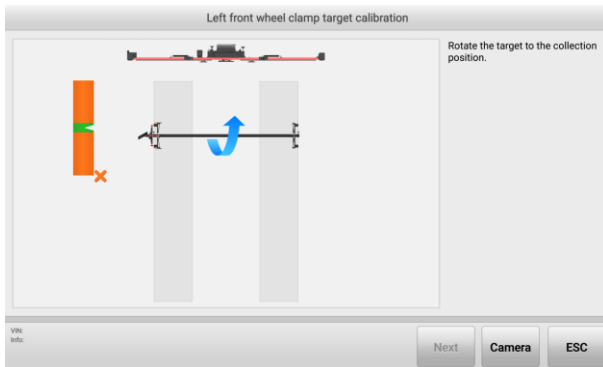

Figure 10-28 Start Calibration (Using a Calibration Bar) 3

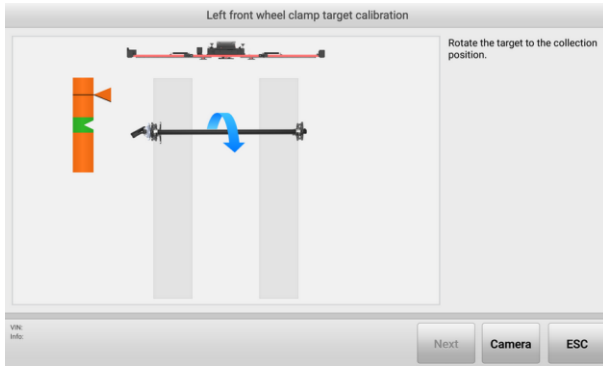

Figure 10-29 Start Calibration (Using a Calibration Bar) 4

11. When the arrows and the indicated block images turn green, stop rotating the calibration bar. The tablet will start collecting data automatically.

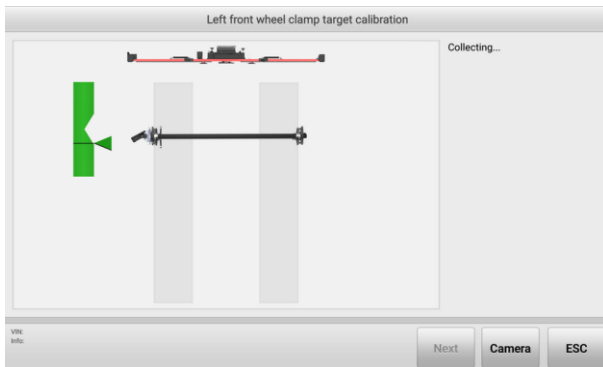

Figure 10-30 Start Calibration (Using a Calibration Bar) 5



12. After collecting data, the tablet will display the calibration result automatically. If the screen displays , it indicates that the calibration is successful. You can tap **ESC** to exit the function. If the screen displays , it indicates the calibration has failed, you need to tap **Recalibrate** to calibrate again.



Figure 10-31 Calibration Result Screen

B. Using a Vehicle

➤ **To calibrate wheel clamp (rim clamp) and target by using vehicle**

1. Select **Settings** from the MaxiSys Job Menu.
2. Tap **ADAS & Aligner Settings** on the left of the screen.
3. Tap **Maintenance & Service**, then select **Wheel clamp target calibration**.
4. Select **Wheel clamp target calibration — with vehicle** from the right of the screen. See [Figure 10-23 Select Calibration Method](#).
5. Select wheel clamp (rim clamp) needed for calibration. Here we select the left front wheel clamp (rim clamp) installed with the target as an example. See [Figure 10-24 Select Target for Calibration](#).
6. As shown in the on-screen guides, drive the vehicle onto the lift; steer ahead; lock steering wheel holder stand tool; place transmission in neutral; and release parking brake. Then install the left front wheel clamp (rim clamp) with the left front target on the left front wheel and raise the front axle.

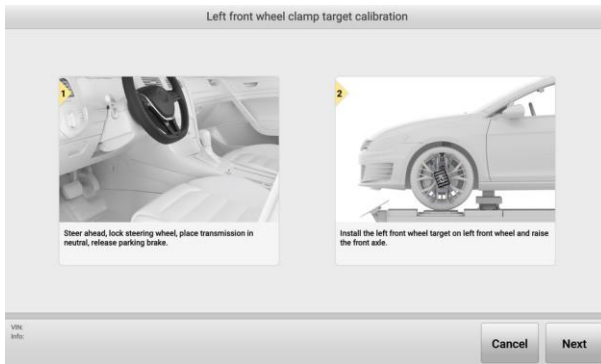

Figure 10-32 Calibration Preparation (Using a Vehicle) 1

7. Tap **Next** to continue. Follow the on-screen guides to place the calibration frame about 2.2 m from the center of the front wheel, and ensure that the centers of the calibration frame and the vehicle are aligned. Then press **UP** and **DOWN** buttons on the back of the calibration frame to adjust the crossbar height so that the crossbar is roughly at the same height as the center of the front wheel.

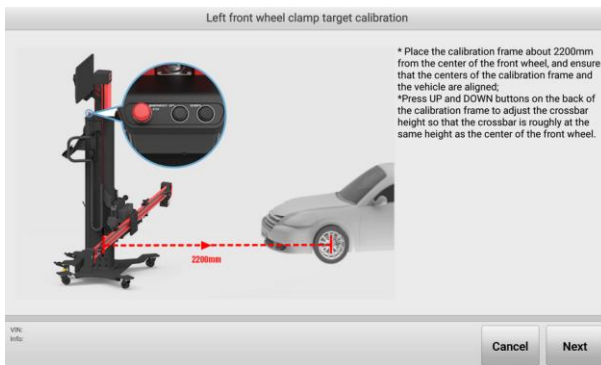

Figure 10-33 Calibration Preparation (Using a Vehicle) 2

8. If the steps above are completed, tap **Next** to continue. If the distance is not within the required range, the tablet will prompt you to adjust it to the required range. In this case, you need to move the calibration frame to adjust the distance until the required range is reached.

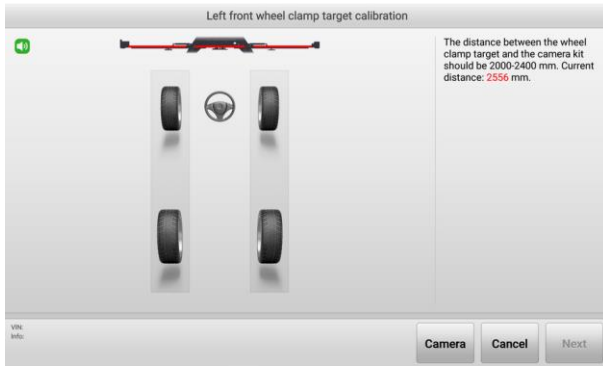

Figure 10-34 Start Calibration (Using a Vehicle) 1

9. Tap **Next** when the centers of the calibration frame and the vehicle are aligned, the crossbar is adjusted to the required height, and the distance between the calibration frame and the front vehicle is in the required range. Then the tablet will prompt you that everything is ready for the next steps.

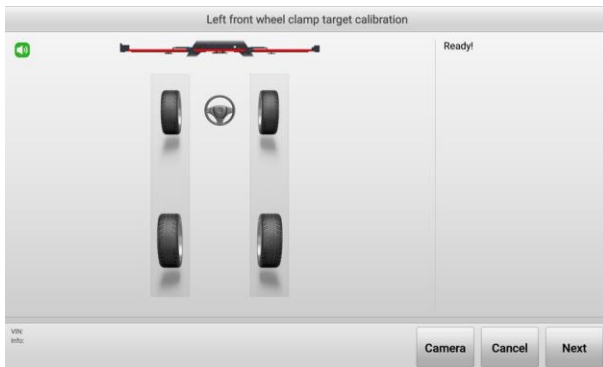

Figure 10-35 Start Calibration (Using a Vehicle) 2

10. Follow the on-screen guides to turn the steering wheel so that the target is in the collection position.

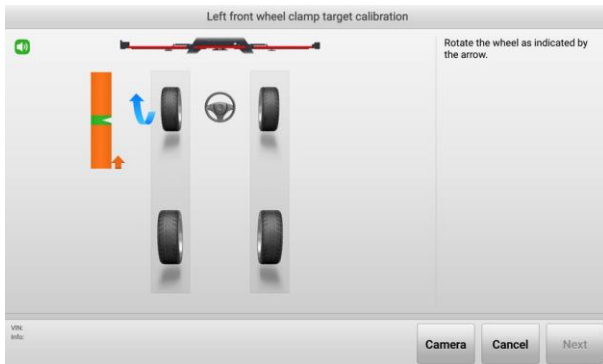

Figure 10-36 Start Calibration (Using a Vehicle) 3

11. When the arrows and the indicated block images turn green, stop turning the steering wheel. The tablet will start collecting data automatically.

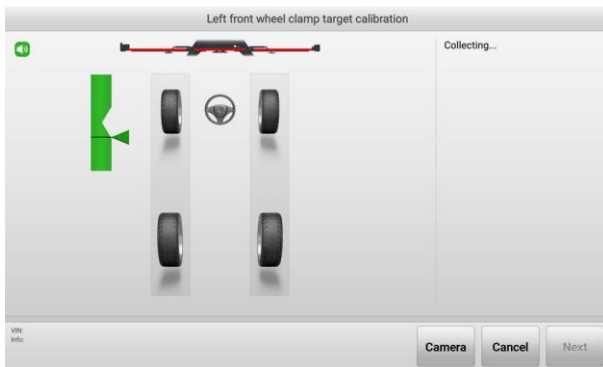



Figure 10-37 Start Calibration (Use a Vehicle) 4

12. After collecting data, the tablet will display the calibration result automatically. If the screen displays , it indicates that the calibration is successful. You can tap **ESC** to exit the function. If the screen displays , it indicates the calibration has failed. You need to tap **Recalibrate** to calibrate again.

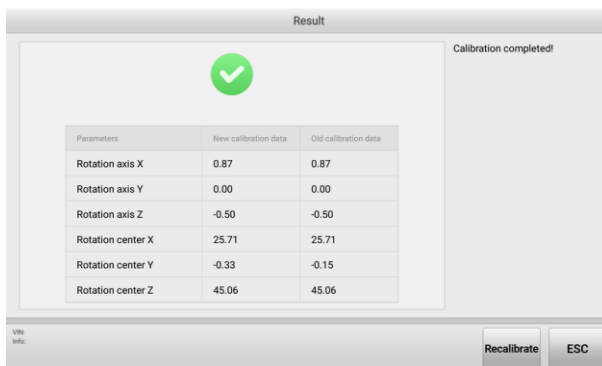

Figure 10-38 Calibration Result Screen (Using a Vehicle)

10.7.5.4 Accuracy Check

Aligner accuracy check is recommended when:

1. The aligner suffered a high-intensity collision.
2. The accuracy check has not been performed for more than six months.

The software provides three kinds of accuracy check methods: Accuracy Check (Use Calibration Bar); Accuracy Check (Use Vehicle); Quick Accuracy Check.

A. Using a Calibration Bar

Performing accuracy check with calibration bar, the overall accuracy of the measurement system composed of cameras and wheel clamp and target can be accurately and reliably detected.

➤ To perform accuracy check with a calibration bar

1. Select **Settings** from the MaxiSys Job Menu.
2. Tap **ADAS & Aligner Settings** on the left of the screen.
3. Tap **Maintenance & Service**, then select **Accuracy Check**.

🔗 NOTE

Ensure the calibration frame Wi-Fi is connected, or the maintenance & service function cannot be activated.

4. Select **Accuracy Check – with calibration bar** in the right of the screen.
5. Follow the on-screen guides. Move the calibration bar to the position about 2.2 m directly in front of the calibration frame. Install the front wheel clamps (rim clamps) and targets on the calibration bar, and align the locating pin with the locating hole. Then tighten the nut.

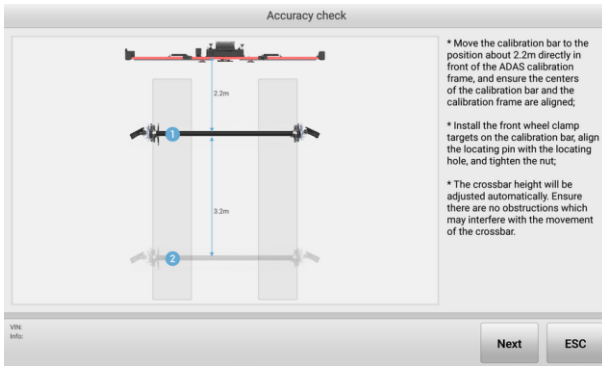

Figure 10-39 Accuracy Check Screen (Using a Calibration Bar) 1

6. Tap **Next**. The crossbar height will be adjusted automatically, and will enter the following screen. As shown in the screen guide, move the calibration bar so that the values of 'Offset', 'L-Distance', and 'Distance Diff' are displayed in green.



Figure 10-40 Accuracy Check Screen (Using a Calibration Bar) 2

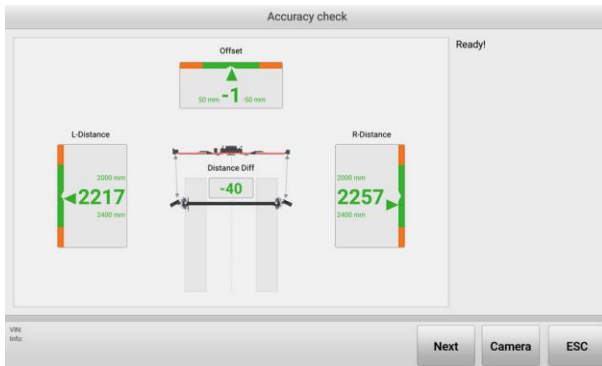

Figure 10-41 Accuracy Check Screen (Using a Calibration Bar) 3

7. Then tap **Next** to enter the following screen. Rotate the calibration bar according to the screen prompts to collect data. When the arrows and the indicated block images turn green, then stop rotating the calibration bar.

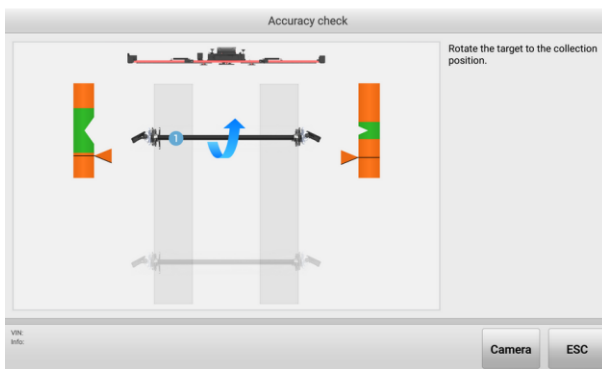

Figure 10-42 Accuracy Check Screen (Using a Calibration Bar) 4

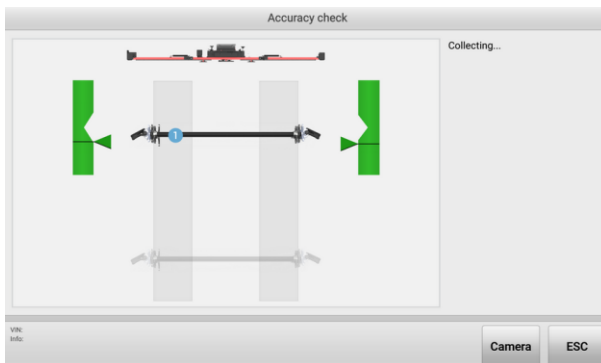



Figure 10-43 Accuracy Check Screen (Using a Calibration Bar) 5

8. The system will automatically enter the next screen. After the data is successfully collected, the calibration result will display automatically. If the screen displays , it indicates that the calibration is successful; if the screen displays , it indicates the calibration has failed, and needs to be recalibrated.

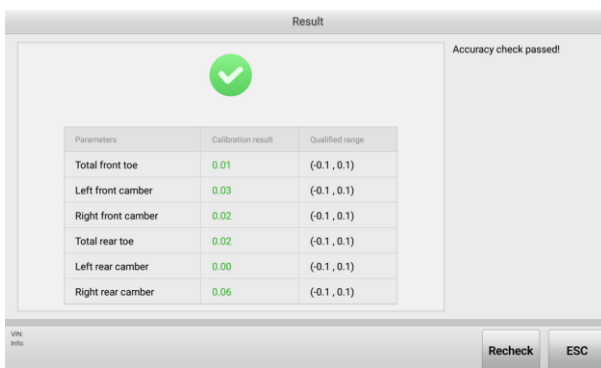

Figure 10-44 Accuracy Check Result Screen

B. Using a Vehicle

Performing accuracy check with vehicle, the overall accuracy of the measurement system consisting of cameras and rim clamp and target can be detected by vehicles without a calibration bar. However, the accuracy of the inspection is affected by the condition of the vehicle, so it is recommended to select a sports vehicle having a good condition for inspection.

- **To perform accuracy check with a vehicle**
 1. Select **Settings** from the MaxiSys Job Menu.
 2. Tap **ADAS & Aligner Settings** on the left of the screen.
 3. Tap **Maintenance & Service**, then select **Accuracy Check**.

NOTE

Ensure the calibration frame Wi-Fi is connected, or the maintenance & service function cannot be activated.

4. Select **Accuracy Check — with vehicle** in the right of the screen.
5. Follow the screen guide to set the vehicle into required status.

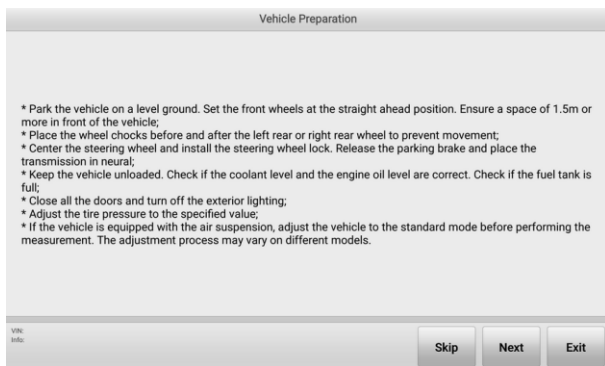

Figure 10-45 Vehicle Preparation

6. Tap **Next** if the vehicle is set to the required status. Follow the guides shown on the screen to position the auxiliary tool step by step.

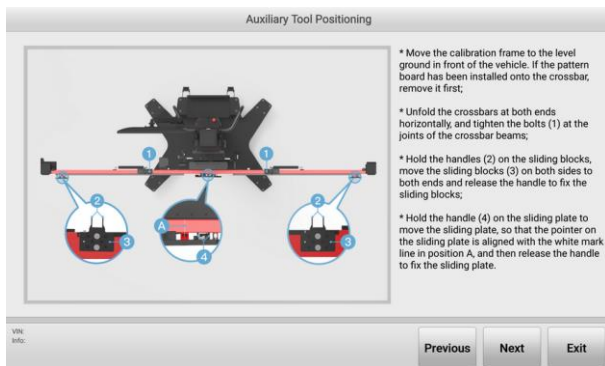

Figure 10-46 Auxiliary Tool Positioning 1

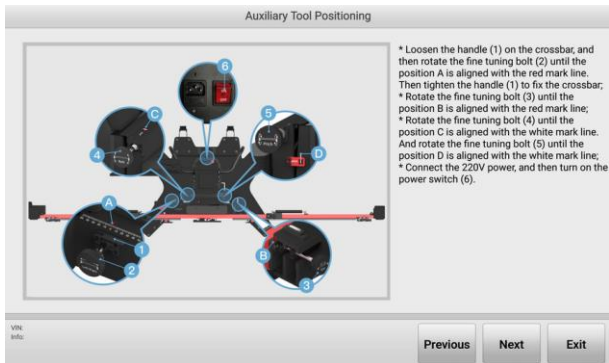

Figure 10-47 Auxiliary Tool Positioning 2

7. Place the calibration frame directly in the front of the vehicle, and follow the screen guides to operate the calibration frame and auxiliary tools.

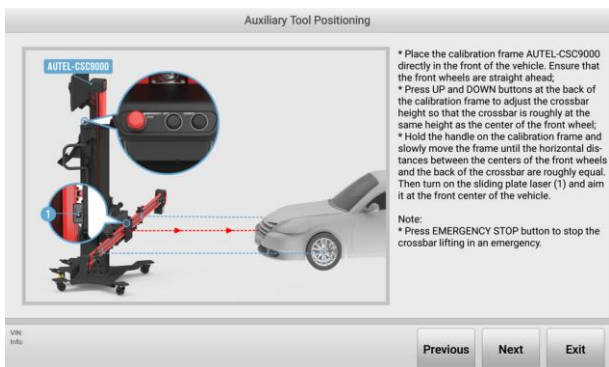

Figure 10-48 Auxiliary Tool Positioning 3

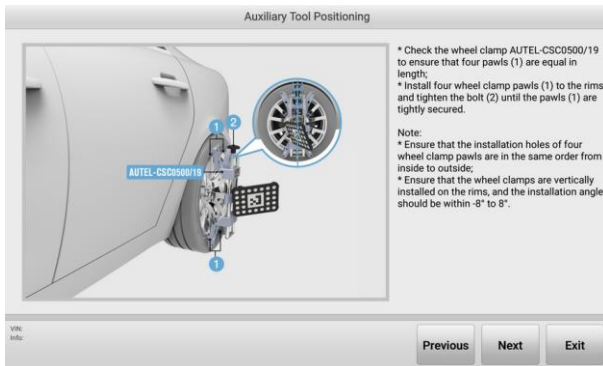

Figure 10-49 Auxiliary Tool Positioning 4

8. After the auxiliary tools are well positioned, tap the **Next** button, the crossbar will be adjusted automatically and search the target, and the tablet will enter the following screen. Follow the screen guide to move the rear wheel chock backward for about 30 cm, and push the vehicle backward, so that the values are displayed green. When the arrows and indicated block images are displayed green, stop pushing the vehicle and wait the tablet to enter the next screen.

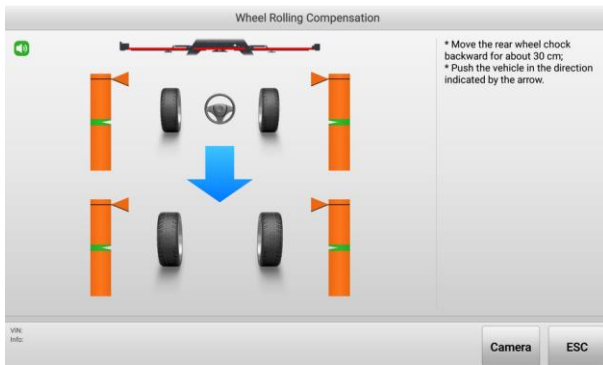

Figure 10-50 Wheel Rolling Compensation 1

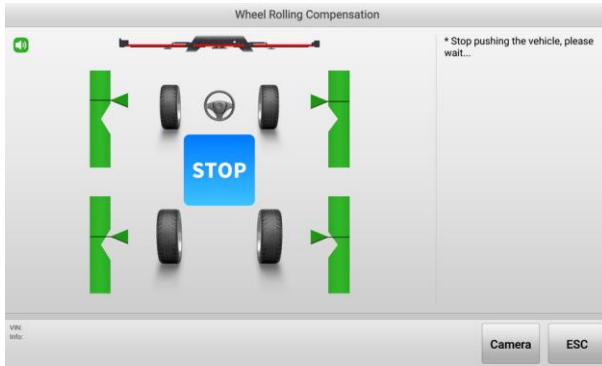

Figure 10-51 Wheel Rolling Compensation 2

9. Then push the vehicle forward. When the arrows and indicated block images are displayed green, stop pushing the vehicle and wait the tablet to enter the next screen.

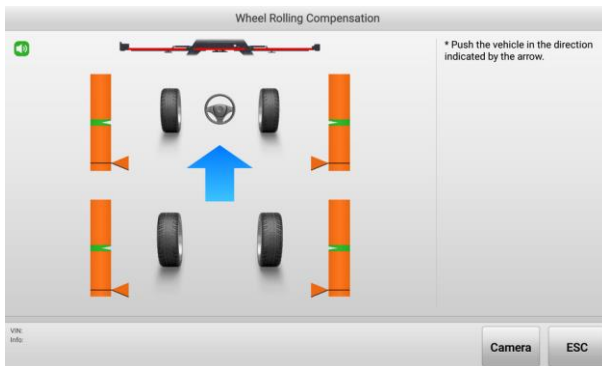

Figure 10-52 Wheel Rolling Compensation 3

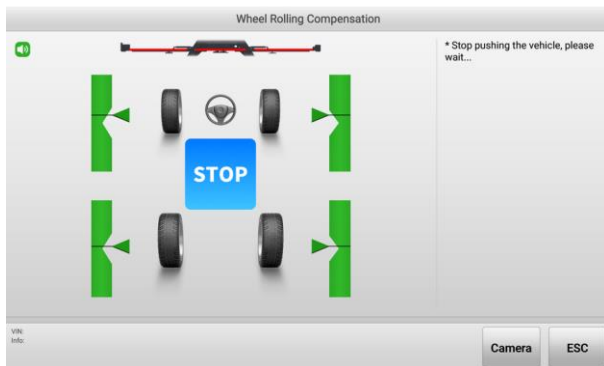



Figure 10-53 Wheel Rolling Compensation 4

10. Place the calibration frame directly behind the rear of the vehicle, then follow the screen guides to complete the procedures, which are similar to the previous operation.
11. After the operation is completed, the calibration result will display automatically. If the screen displays , it indicates that the calibration is successful; if the screen displays , it indicates the calibration has failed, and needs to be recalibrated.

C. Quick Accuracy Check

Quick accuracy check is automatically performed every six months by default. The Accuracy Check Interval can be changed through Wheel Alignment Software Settings. Quick accuracy check can detect problems in the measurement system formed by the camera and target, but not including the wheel clamp or tire clamp.

➤ To perform quick accuracy check

1. Select **Settings** from the MaxiSys Job Menu.
2. Tap **ADAS & Aligner Settings** on the left of the screen.
3. Tap **Maintenance & Service**, then select **Accuracy Check**.

NOTE

Ensure the calibration frame Wi-Fi is connected, or the maintenance & service function cannot be activated.

4. Select **Quick accuracy check** in the right of the screen.
5. Follow the screen guide to set the vehicle into required status.

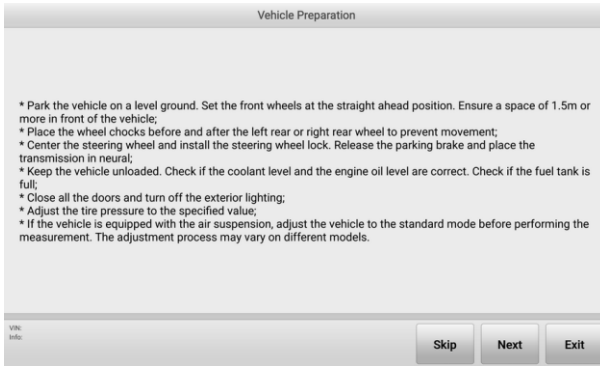

Figure 10-54 Vehicle Preparation Guide

6. Tap **Next** if the vehicle is set to the required status well. Then follow the screen guide to position the auxiliary tool step by step.

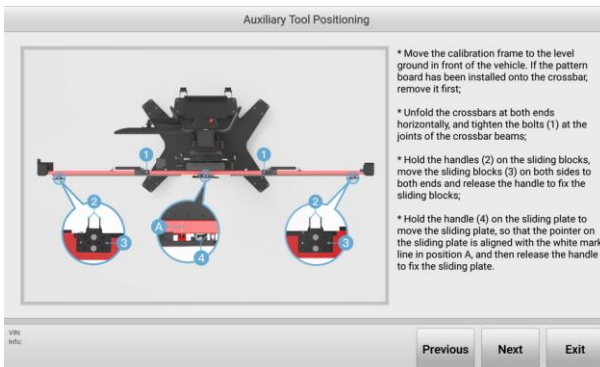

Figure 10-55 Auxiliary Tool Positioning 1

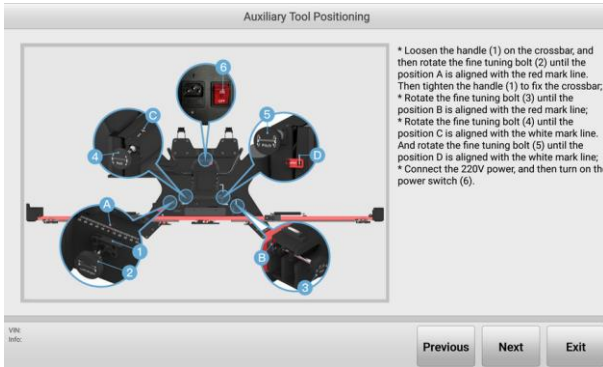

Figure 10-56 Auxiliary Tool Positioning 2

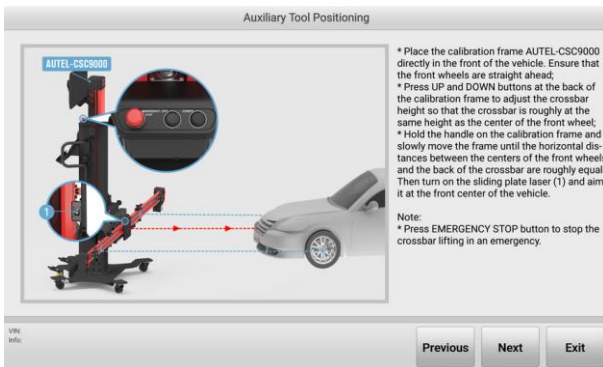

Figure 10-57 Auxiliary Tool Positioning 3

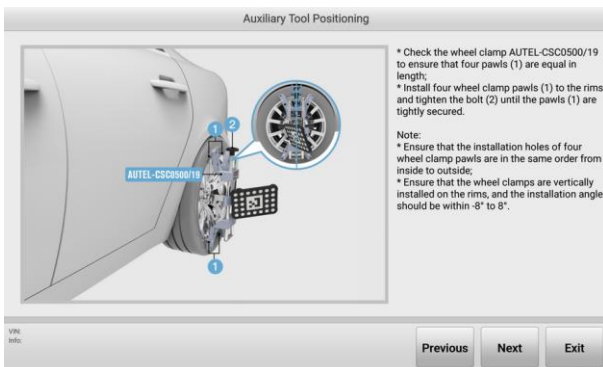

Figure 10-58 Auxiliary Tool Positioning 4

- After positioning the auxiliary tool. Tap the **Next** button, the crossbar height will be adjusted automatically and search the target, and will enter the following screen.

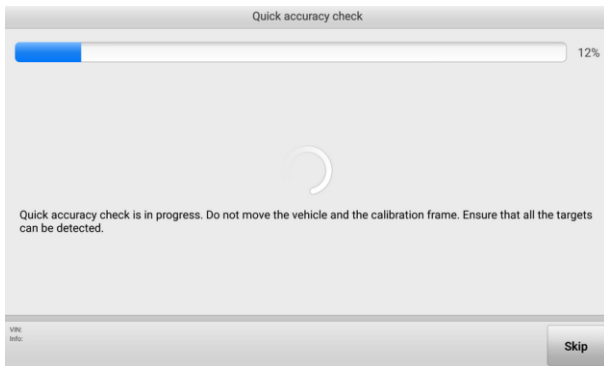



Figure 10-59 Quick Accuracy Check

- The quick accuracy check result will display on the screen after the check progress is completed. If the screen displays , it indicates that the calibration is successful; if the screen displays , it indicates the calibration has failed, and needs to be recalibrated.

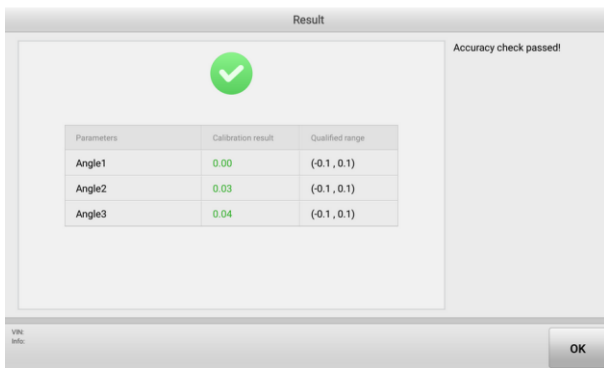

Figure 10-60 Quick Accuracy Check Result

10.7.5.5 Calibration Record Report

All the calibration records are saved here, you can see when and what type of calibration the device was performed.

10.7.5.6 Accuracy Check Interval

This function enables you to set the accuracy check intervals, four options are available: three months, six months, one year, never. The default accuracy check interval is six months.

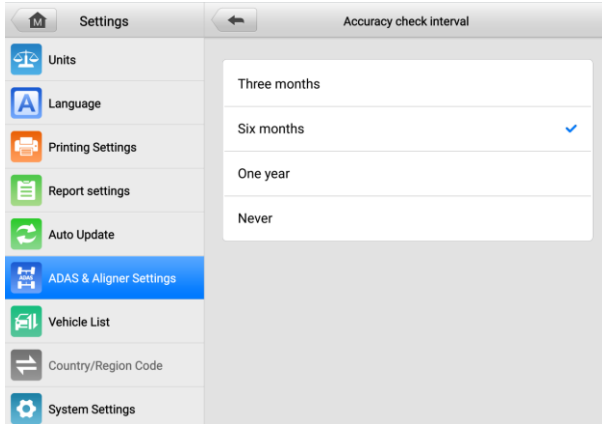

Figure 10-61 Accuracy Check Interval Setting Screen

10.7.5.7 Target Cleaning Interval

This function helps in reminding the operator about the target cleaning frequency, which can be selected in terms of alignment numbers or intervals.

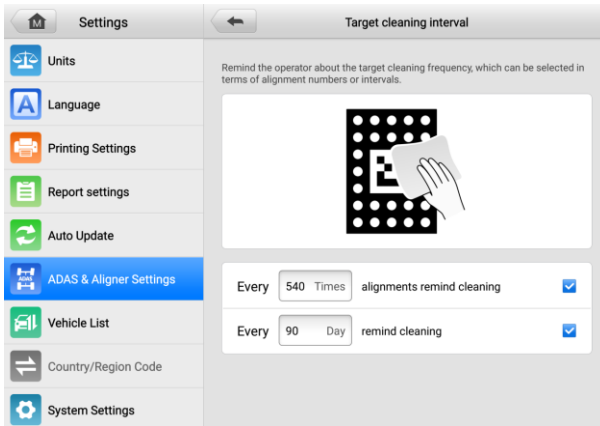

Figure 10-62 Target Cleaning Interval Setting Screen

10.7.6 Wheel Alignment Software Settings

Vehicle Inspection, Measurement Preparation, Measurement Results, Customized Specifications Management, and Restore Default Settings are included in this section.

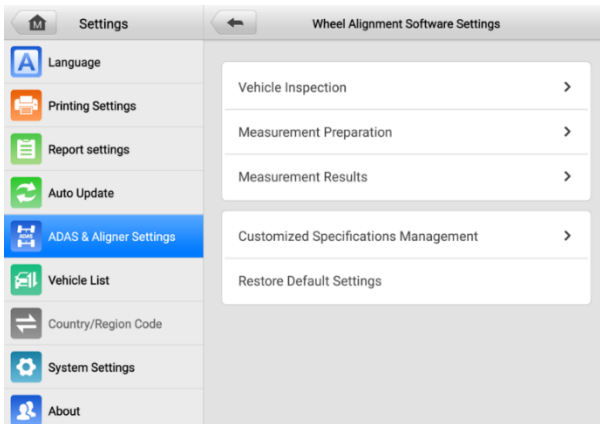

Figure 10-63 Wheel Alignment Software Settings

10.7.6.1 Vehicle Inspection

This function enables you to:

1. Set whether to enable tire inspection or not. This setting will affect whether the tablet will guide you to perform Tread Depth & Pressure Inspection in the Vehicle Check procedure. If the Vehicle Inspection is enabled, the tablet will guide you to perform Tread Depth & Pressure Inspection; if disabled, the tablet will not guide you to perform Tread Depth & Pressure Inspection. For how to perform Tread Depth & Pressure Inspection, refer to [Tread Depth & Pressure Inspection](#).
 - If the tire inspection is activated, you are able to set:
 - 1) Tread depth measuring method: Single Check or All Tread Check.
 - 2) Minimum Tread Depth: when the tread depth is less that the minimum tread depth value you set, the tablet will prompt you to replace the tire immediately.
 - 3) Warning Tread Depth: when the tread depth is less than the value you set, the tablet will issue a warning.
2. Set whether to enable chassis inspection or not. This setting will affect whether the tablet will guide you to perform Chassis Inspection in the Vehicle Check procedure. If the Chassis Inspection is enabled, the tablet will guide you to perform Chassis Inspection; if disabled, the tablet will not guide you to perform Chassis Inspection. For how to perform Chassis Inspection, refer to [Chassis Inspection](#).

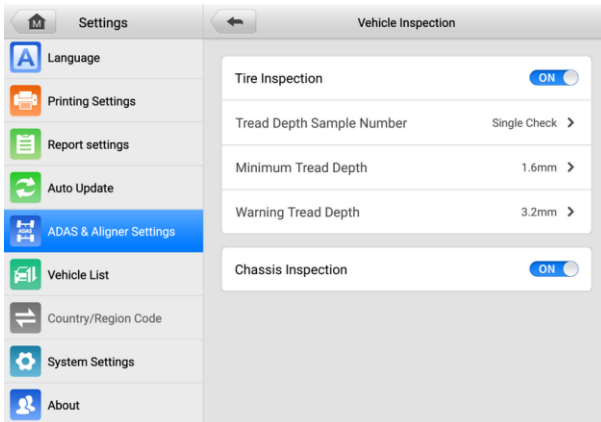

Figure 10-64 Vehicle Inspection Settings Screen

10.7.6.2 Measurement Preparation

This function enables/disables measurement preparation, and will affect whether the tablet will guide you to measure ride height. If the Measurement Preparation is turned on, the tablet will guide you to measure ride height; if turned off, the tablet will not guide you to measure ride height. About how to measure ride height, refer to [Ride Height Measurement](#).

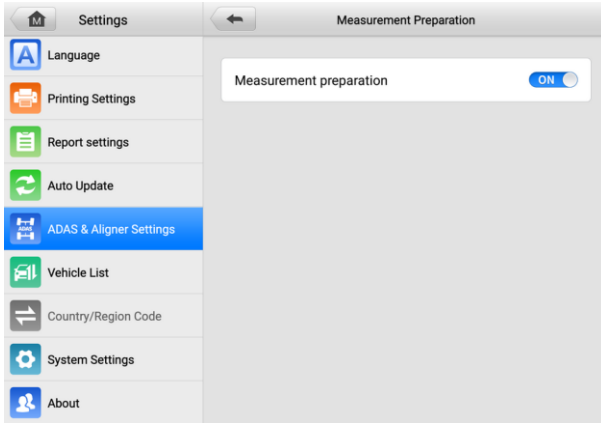

Figure 10-65 Measurement Preparation Setting Screen

10.7.6.3 Measurement Results

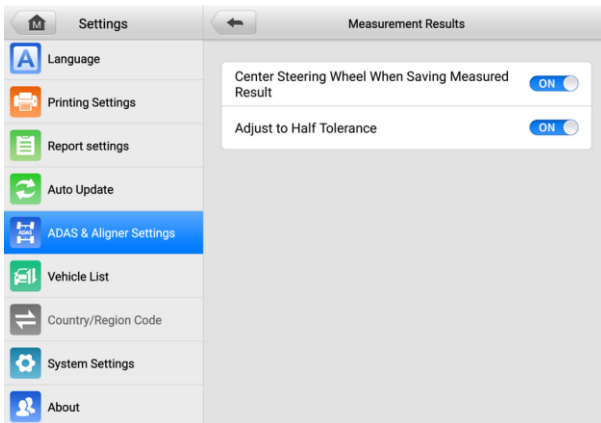

Figure 10-66 Measurement Results Setting Screen

This function enables you to:

1. Whether to center steering wheel when saving measured result.
 - Turn on the function
 - 1) If the wheels are not in straight-ahead position, tap **Save Before Repair** in Measured Result screen, the guide for setting the wheels straight-ahead will be displayed on the screen.



Figure 10-67 Save Before Repair Screen 1

- 2) When the wheels are in straight-ahead position, the tablet will save the data automatically and display the following screen.

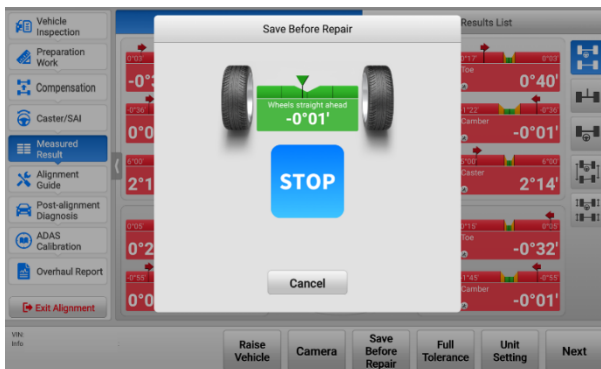

Figure 10-68 Save Before Repair Screen 2

- Turn off the function: the data will be saved directly after tapping **Save Before Repair** in Measured Result screen.

2. Whether to change to Half Tolerance mode.

- 1) If the Half Tolerance mode is enabled, the Measured Result will display in Half Tolerance mode, and the screen looks like the image below.



Figure 10-69 Measured Result (Half Tolerance) Screen

- 2) If the Half Tolerance mode is disabled, the Measured Result will display in Full Tolerance mode, and the screen looks like the image below.



Figure 10-70 Measured Result (Full Tolerance) Screen

10.7.6.4 Customized Specifications Management

The customized specifications are not available currently.

10.7.6.5 Restore Default Settings

This function enables you to restore the default settings of wheel alignment software.

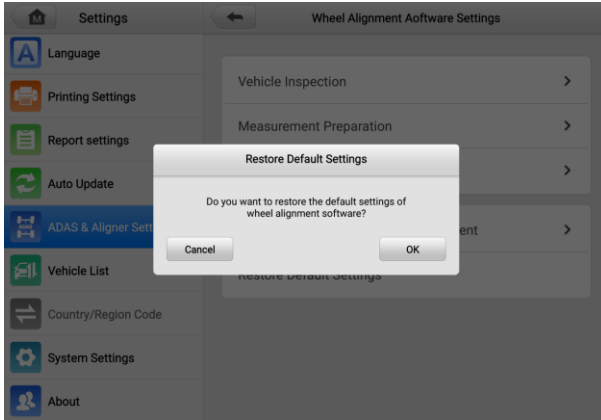

Figure 10-71 Restore Default Settings Screen

The default settings are as follows:

Table 10-1 Default Settings

Item	Default Setting
Angle Display Format	Degree & Minute
Toe Display Format	Degree & Minute
Ride Height Unit	mm
Tread Depth Unit	mm
Track Width & Wheelbase Unit	mm
Tire Pressure Unit	bar

Item	Default Setting
Weight Unit	kg
Clamp Type	Rim Clamp
Connect Tread Measuring Tool	Enable TBE Device Searching
Select Height Measuring Tool	Tape Measure
Benz Chassis Level Measuring Tool	No Tool
Beep Setting	Turn On
Accuracy Check Interval	Six Months
Target Cleaning Interval	Times: 540 Times Days: 90 Days
Vehicle Inspection	Turn On
Tread Depth Sample Number	Single Check
Minimum Tread Depth	1.6 mm
Warning Tread Depth	3.2 mm
Chassis Inspection	Turn On
Measurement Preparation	Turn On
Center Steering Wheel When Saving Measured Result	Turn On
Adjust to Half Tolerance	Turn On

10.8 Vehicle List

This option allows you to sort the vehicles either by alphabetic order or by frequency of use.

➤ **To adjust the vehicle list setting**

1. Tap the **Settings** application on the MaxiSys Job Menu.
2. Tap **Vehicle List** on the left column.
3. Select the required sort type. A check mark will display to the right of the selected item.
4. Tap the **Home** button in the top-left corner to return to the MaxiSys Job Menu, or select another settings option for system setup.

10.9 AutoVID Setup

This option allows you to enable/disable the automatic vehicle VIN reading function. When this function is active, the tablet will read the vehicle VIN via the communication methods you enabled after the VCI is connected to the vehicle.

10.10 Country/Region Code

This function provides Wi-Fi channel options for different country regions to ensure reliable and stable Wi-Fi communication. Please connect the tablet with VCI device before making adjustment.

➤ **To adjust the country code setting**

1. Tap the **Settings** application on the MaxiSys Job Menu.
2. Tap the **Country/Region Code** option on the left column.
3. Select the appropriate country/region. A confirmation message will display.
4. Tap the **Home** button on the top-left corner to return to the MaxiSys Job Menu, or select another settings option for the system setup.

 **NOTE**

If the tablet cannot find the VCI device via Wi-Fi connection after setting the country code, please connect the VCI with tablet via USB cable or Bluetooth connection to retry.

10.11 System Settings

This function provides you with direct access to the Android system setting interface, where you can adjust various system settings for the Android system platform. Regarding wireless and networks settings, various device settings such as sound and display, as well as system security settings, and check related information about the Android system. Refer to Android documentation for additional information.

10.12 About

The About function provides information of the MaxiSys diagnostic device including the product name, version, hardware, and serial number.

➤ **To check the MaxiSys product information in About**

1. Tap the **Settings** application on the MaxiSys Job Menu.
2. Tap the **About** option on the left column. The product information screen displays on the right.
3. Tap the **Home** button on the top-left corner to return to the MaxiSys Job Menu, or select another settings option for system setup.

11 VCI Manager

The VCI Manager is an application for connecting the MaxiSys tablet with VCI device. This application allows you to pair the tablet with the VCI and to check the communication status. You can either build the connection via the Bluetooth or Wi-Fi, of which the latter is more stable and faster in speed for module operation.

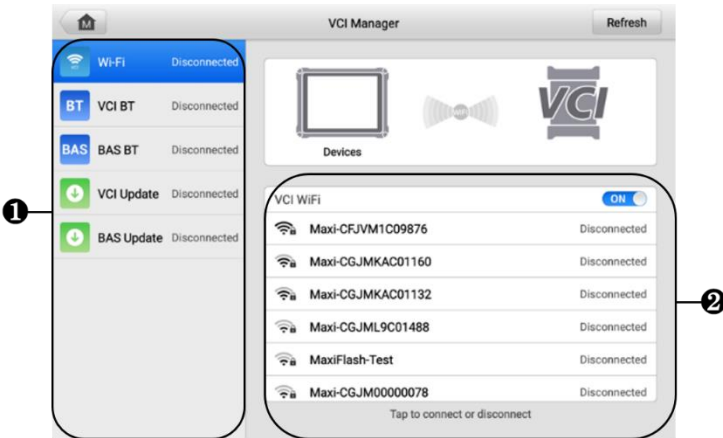

Figure 11-1 VCI Manager Screen

1. **Connection Mode:** five connection modes are available. The connection status displays adjacent to each mode.
 - Wi-Fi Connection — when connected to a wireless device, the connection state displays as “Connected.” Otherwise, it displays as “Disconnected.”
 - VCI Bluetooth Pairing — when the VCI is paired to the tablet via Bluetooth, the connection status displays as “Connected.” Otherwise, it displays as “Disconnected.”
 - BAS Bluetooth Pairing— when paired to a battery tester via Bluetooth, the connection status displays as “Connected.” Otherwise, it displays as “Disconnected.”
 - VCI Update — connects the VCI to the MaxiSys tablet, then updates the VCI firmware through the tablet.
 - BAS Update — connects the battery tester to the MaxiSys tablet, then updates the battery tester’s firmware through the tablet.

2. **Settings:** this section allows you to manage wireless pairing or set up network connection. Toggle the **ON/OFF** button to **ON**. The available devices for pairing will display. Tap the needed one to start pairing.

11.1 Wi-Fi Connection

Wi-Fi Connection is an advanced function for quick linkage with VCI. Since Wi-Fi connection supports 5G, the MaxiSys tablet and VCI device share a faster and more stable connection when using this communication method. The tablet can be operated up to 50 meters away from the VCI device when connected to the vehicle.

➤ **To connect the VCI to the tablet via Wi-Fi**

1. Power on the tablet.
2. Connect the 26-pin end of the main cable to the VCI's vehicle data connector.
3. Connect the 16-pin end of the main cable to the vehicle data link connector (DLC).
4. Tap **VCI Manager** on the MaxiSys Job Menu of the tablet.
5. Select **Wi-Fi** from the connection mode list.
6. Swipe the Wi-Fi toggle button to **ON**. Tap **Refresh** at the top-right corner. The device will start to search for available units.
7. Depending on the VCI type you use, the device name may display as "Maxi" suffixed with a serial number. Select the appropriate device for connection.
8. When the connection is established, the connection status displays as "Connected".
9. The VCI button on the system navigation bar at the bottom of the screen displays a green Wi-Fi icon, indicating the tablet is connected to the VCI device.
10. Tap the connected device again to disconnect the device.
11. Tap **Back** on the top-left corner to return to the MaxiSys Job Menu.

 **NOTE**

To ensure a quick connection, please connect in a steady network environment.

11.2 VCI Bluetooth Pairing

Bluetooth Pairing is the basic way for wireless connection. The VCI device needs to be either connected to a vehicle or to an available power source, so that it is powered up during the synchronization procedure. Make sure the tablet has a charged battery or is connected to an AC/DC power supply.

➤ **To pair the VCI device with the tablet**

1. Power on the tablet.
2. Connect the 26-pin end of the main cable to the VCI's vehicle data connector.
3. Connect the 16-pin end of the main cable to the vehicle data link connector (DLC).
4. Tap **VCI Manager** on the MaxiSys Job Menu of the tablet.
5. Select **VCI BT** from the connection mode list.
6. Swipe the Bluetooth toggle button to **ON**. Tap **Scan** at the top-right corner. The device will start to search for available pairing units.
7. Depending on the VCI type you use, the device name may display as "Maxi" suffixed with a serial number. Select the appropriate device for pairing.
8. When paired successfully, the connection status displays as "Connected."
9. Wait a few seconds, and the VCI button on the system navigation bar at the bottom of the screen will display a green BT icon, indicating the tablet is connected to the VCI device.
10. Tap the connected device again to disconnect the device.
11. Tap **Back** on the top left to return to the MaxiSys Job Menu.

 **NOTE**

A VCI device can be paired to only one tablet at a time, and once it's been paired, the device will not be discoverable for any other unit.

11.3 BAS Bluetooth Pairing

The BT506 battery tester device can be connected with the tablet via Bluetooth. Ensure that the BT506 battery tester is sufficiently charged or is connected to the external power supply before use.

➤ **To pair the Battery Tester with the tablet**

1. Power on the tablet and the battery tester.
2. Tap **VCI Manager** on the MaxiSys Job Menu of the tablet.
3. Select **BAS BT** from the connection mode list.
4. Swipe the Bluetooth toggle button to **ON**. Tap **Scan** at the top-right corner of the screen. The device will start to search for available units to pair with.
5. Depending on the type of battery tester, the device name may appear as "Maxi" suffixed with the battery test's serial number. Select the appropriate device for pairing.
6. When paired successfully, the connection status reads "Connected."

11.4 VCI Update

VCI Update provides the latest update for the connected VCI device. Before updating the VCI firmware, make sure the tablet network is stable, and do not leave the VCI Update page during upgrade.

➤ **To update the VCI firmware**

1. Power on the tablet.
2. Connect the VCI device to the tablet via USB cable.
3. Tap **VCI Manager** on the MaxiSys Job Menu of the tablet.
4. Select **VCI Update** from the connection mode list.
5. If the installed version is not the latest one, the current version and the latest version will display on the screen after a few seconds. Tap **Update Now** to update the VCI firmware if available.

11.5 BAS Update

Before updating the battery tester firmware, please make sure the network connection is stable.

➤ **To update the battery tester firmware**

1. Power on the tablet and the battery tester.
2. Connect the battery tester to the tablet via Bluetooth or USB cable.
3. Tap the **VCI Manager** application on the MaxiSys Job Menu of the tablet.
4. Select **BAS Update** from the connection mode list.
5. If the installed version is not the latest one, the current version and the latest version will display on the screen after a few seconds. Tap **Update Now** to update the BAS firmware if available.

 **NOTE**

Do not leave the BAS Update page during upgrade.

12 Update



The Update application on the tablet downloads the latest version of the software. The updates improve the MaxiSys applications' capabilities, typically by adding new tests, new model coverage or by adding new or enhanced applications.

The tablet automatically searches for available updates for all of the MaxiSys software when it is connected to the Internet. Any updates that are found can be downloaded and installed on the device. This section describes update procedures in the MaxiSys system.

NOTE

Ensure the tablet is registered before utilizing the Update application. See [Autel User Center](#) for a comprehensive registration guide.

➤ To update the software

1. Power up the tablet, and ensure that it is connected to a power source and has a steady Internet connection.
2. Tap the **Update** application button from the MaxiSys Job Menu. The Update application screen displays.
3. On the Update screen, tap the **Get** button to update the specific item(s) or tap the **Update All** button to update all available items.
4. Tap **More** to view the details of all the available updates. You can also tap the **Get** or **Update All** button for update.
5. During the update, tap the  icon to suspend the updating process. Tap the  icon to resume the update and the process will continue from the pause point.
6. When the updating process is completed, the software will be installed automatically. The new version will replace the older version.

NOTE

For the account management, proceed to the Member Center tab.

13 Support

This application launches the Support platform which synchronizes Autel's online service base station with the MaxiSys tablet. Connected to Autel's service channel and online communities, the Support application provides the quickest way for problem solutions, allowing you to send help requests to obtain direct service and support.

13.1 Support Screen Layout

The Support application interface is navigated by the Home button on the top toolbar. And the main section of the Support screen is divided into two sections. The narrow column on the left is the main menu; select one subject from the main menu to display the corresponding function screen on the right.

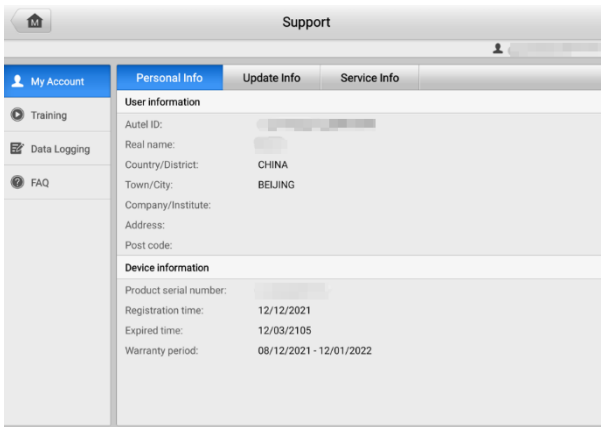

Figure 13-1 Support Application Screen

13.2 My Account

The My Account screen displays the comprehensive information of the user and the product, which is synchronized with the online registered account, including Personal Information, Update Information, and Service Information.

13.2.1 Personal Information

The User Information and Device Information are both included under the Personal Information section.

- User Information — displays detailed information of your registered online Autel account, such as your Autel ID, name, address, and other contact information.
- Device Information — displays the registered product information, including the product serial number, registration time, expired time, and warranty period.

13.2.2 Update Information

The Update Information section displays a detailed list of the product's software update history, including the product serial number, software version or name, and the update time.

13.2.3 Service Information

The Service Information section displays a detailed record list of the device's service history information. Every time the device has been sent back to Autel for repair, the device's serial number and other information, such as the fault type, changed components, or system reinstallation will be recorded and updated to the associated online product account that will be synchronized to the Service Information section.

13.3 Training

The Training section provides quick links to Autel's online video accounts. Select a video channel by language to see all available Autel online tutorial videos on such topics as product usage techniques and vehicle diagnostics practices.

13.4 Data Logging

The Data Logging section keeps records of all **Feedback** (submitted), **No feedback** (not submitted but saved) or **History** (up to the latest 20 test records) data loggings on the diagnostic system. The support personnel will receive and process the submitted reports through the Support platform. The solution will be sent back as soon as possible. You may continue to correspond with the Support platform until the issue is resolved.

➤ **To make a reply in a Data Logging session**

1. Tap on the **Feedback** tag to view the list of submitted data loggings.
2. Select a specific item to view the latest update of the processing progress.
3. Tap on the input field on the bottom of the screen and enter your reply, or tap the **Audio** button to record a voice message, or tap the **Camera** button to take a screenshot.
4. Tap **Send** to deliver your message to Autel Support.

13.5 FAQ

The FAQ section provides comprehensive references for all questions frequently asked and answered about the use of Autel's online member account and shopping and payment procedures.

- Account — displays questions and answers about the use of Autel's online user account.
- Shopping — displays questions and answers about online product purchase methods or procedures.
- Payment — displays questions and answers about online product payment methods or procedures.

14 MaxiViewer

The MaxiViewer application allows you to search the functions supported by our tools and the version information. There are two ways for searching, either by searching the tool and the vehicle or searching the functions.

➤ **To search by the vehicle**

1. Tap the **MaxiViewer** application on the MaxiSys Job Menu. The MaxiViewer application screen displays.
2. Tap the tool name on the top-left corner to drop down the tool list. Tap the one you want to search.
3. Tap the vehicle brand, model, and year you want to search.

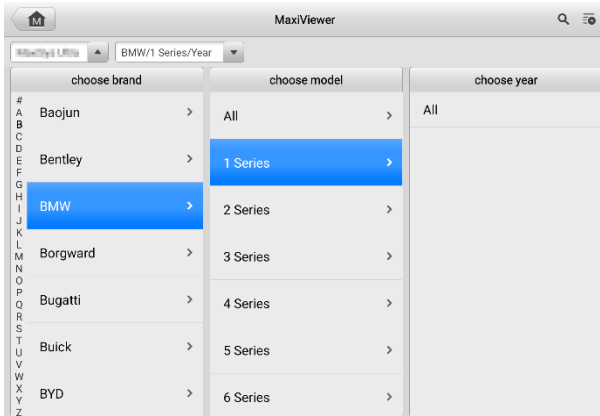

Figure 14-1 MaxiViewer Screen 1

4. All the functions supported by the selected tool for the selected vehicle display as several columns.

Year	System	Engine	Chassis	Function	Sub function	Version
/	Body	B37	F20	Service	- Newly address the air distribution flap	Above BM W_V12.00
/	Body	B37	F21	Service	- Newly address the air distribution flap	Above BM W_V12.00
/	Body	B38	F52	Service	- Newly address the air distribution flap	Above BM W_V12.00
/	Body	B47	F20	Service	- Newly address the air distribution flap	Above BM W_V12.00
/	Body	B47	F21	Service	- Newly address the air distribution flap	Above BM W_V12.00
/	Body	B58	F20	Service	- Newly address the air distribution flap	Above BM W_V12.00
/	Body	B58	F21	Service	- Newly address the air distribution flap	Above BM W_V12.00

Figure 14-2 MaxiViewer Screen 2

➤ **To search by the functions**

1. Tap the **MaxiViewer** application on the MaxiSys Job Menu. The MaxiViewer application screen displays.
2. Tap the tool name on the top-left corner to drop down the tool list. Tap the one you want to search.
3. Enter the function you want to search in the top-right search box. The screen will display all vehicles that support this function, along with information such as the vehicles' year, system, function, sub-function, and version.

Model	Year	System	Engine	Chassis	Function	Sub function	Version
1 Series	/	EPS (Electric Power Steering)	/	E81	ECU information	/	Above BMW_V1 2.00
1 Series	/	EPS (Electric Power Steering)	/	E82	ECU information	/	Above BMW_V1 2.00
1 Series	/	EPS (Electric Power Steering)	/	E87	ECU information	/	Above BMW_V1 2.00
1 Series	/	EPS (Electric Power Steering)	/	E88	ECU information	/	Above BMW_V1 2.00
1 Series	/	EPS (Electric Power Steering)	/	F20	ECU information	/	Above BMW_V1 2.00
1 Series	/	EPS (Electric Power Steering)	/	F21	ECU information	/	Above BMW_V1 2.00
1 Series	/	EPS (Electric Power Steering)	/	F52	ECU information	/	Above BMW_V1 2.00

Figure 14-3 MaxiViewer Screen 3

 **NOTE**

Fuzzy search is supported. Type in some part of the function-related keywords to find all the available information.

15 ADAS & Wheel Alignment Filter

The ADAS & Wheel Alignment Filter application enables you to implement a specified ADAS calibration, or to quickly check if the wheel alignment, SAS function, and ADAS calibration after a wheel alignment are supported or required.

15.1 ADAS Filter

When you need to calibrate some of the vehicle systems, filter via the ADAS & Wheel Alignment Filter application, no need to perform the whole ADAS calibration procedures any more.

➤ **To perform ADAS Filter function**

1. Tap the **ADAS & Wheel Alignment Filter** application from the MaxiSys Job Menu. The ADAS & Wheel Alignment Filter application screen displays, and the ADAS tab is selected by default.
2. Tap the product type on the top-left corner to open the drop-down list. Select the ADAS calibration tool. Here we select IA900 for illustration.

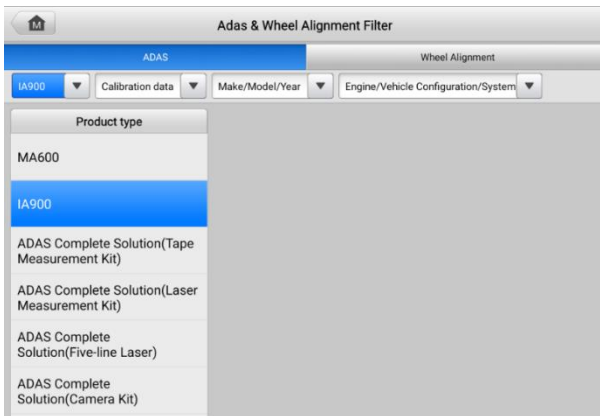

Figure 15-1 ADAS Filter Screen 1

3. Select the calibration mode you need from the drop-down list.

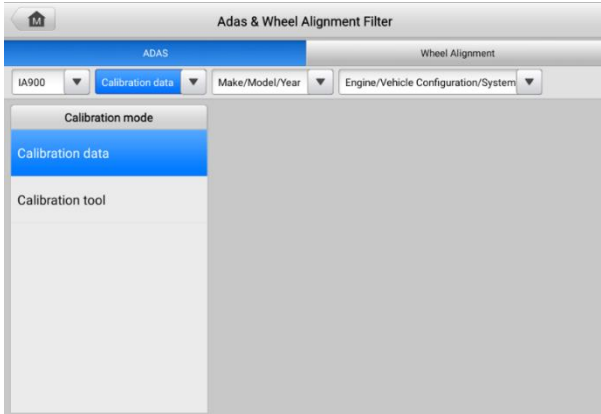

Figure 15-2 ADAS Filter Screen 2

4. Select the vehicle's brand, model, and year from the drop-down list.

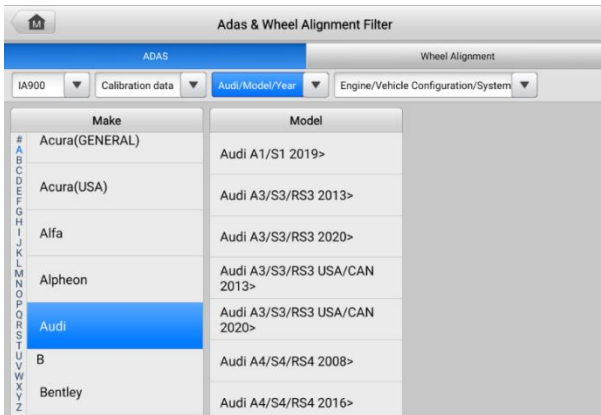

Figure 15-3 ADAS Filter Screen 3

- Select the vehicle system that needs to perform ADAS calibration.

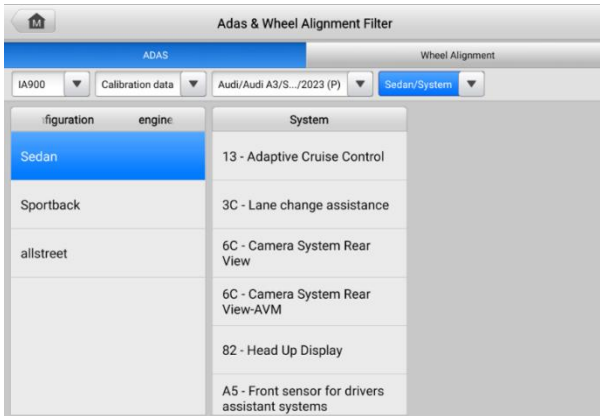

Figure 15-4 ADAS Filter Screen 4

- The calibration procedures will display on the screen. Follow the on-screen instructions to complete the calibration.

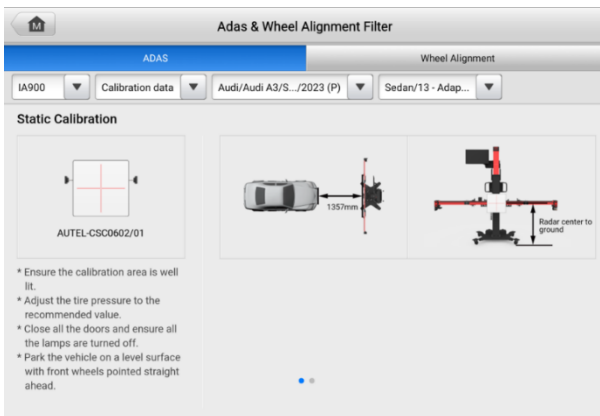

Figure 15-5 ADAS Filter Screen 5

15.2 Wheel Alignment Filter

The Wheel Alignment Filter function is an efficient way to quickly check if the wheel alignment, SAS function, and ADAS calibration after a wheel alignment are supported or required.

➤ **To perform Wheel Alignment Filter function**

1. Tap the **ADAS & Wheel Alignment Filter** application from the MaxiSys Job Menu. The ADAS & Wheel Alignment Filter application screen displays. Select the **Wheel Alignment** tab.
2. Select the wheel alignment tool from the drop-down list.

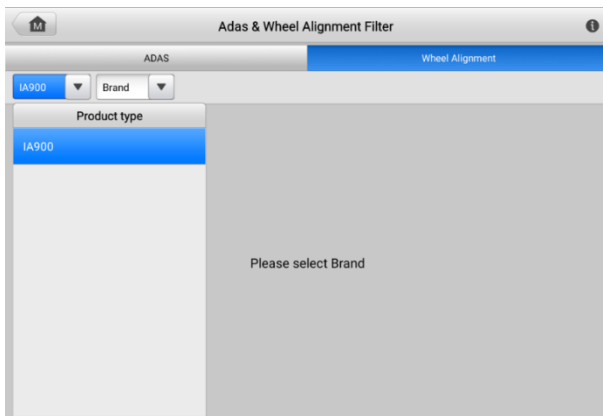

Figure 15-6 Wheel Alignment Filter Screen 1

3. Select the vehicle's brand from the drop-down list. Whether wheel alignment, SAS function, and ADAS calibration after a wheel alignment are supported or required will be displayed on the screen. To find your vehicle more precisely, you can further filter by selecting the model and year of your vehicle.

ProductType	Brand	Model	Year	Wheel Alignment	SAS Function	ADAS Required After Alignment
IA900	Audi	100 1976-(C2)	1976-1977	●	—	—
IA900	Audi	100 Quattro 1987>(C3)	1987-1991	●	—	—
IA900	Audi	100 Quattro 1991>(C4)	1991-1996	●	—	—
IA900	Audi	100 Quattro USA/Canada 1989>(C4)	1989-1994	●	—	—
IA900	Audi	100 USA/Canada 1975>(C2)	1975-1977	●	—	—
IA900	Audi	100 USA/Canada 1989>(C4)	1989-1994	●	—	—
IA900	Audi	200 Quattro USA/Canada 1989>	1989-1994	●	—	—
IA900	Audi	200 USA/Canada 1989>	1989-1994	●	—	—

Figure 15-7 Wheel Alignment Filter Screen 2

16 MaxiVideo

The MaxiVideo application configures the MaxiSys tablet to operate as a digital video scope by simply connecting the tablet to a MaxiVideo Digital Inspection Camera. This function allows you to examine difficult-to-reach areas normally hidden from sight, with the ability to record digital still images and videos, which offers you an economical solution to inspect machinery, facilities, and infrastructure in a safe and quick way.

 **NOTE**

1. The MaxiVideo Digital Inspection Camera and its fittings are additional accessories, and need to be purchased separately. Both sizes (8.5 mm and 5.5 mm) of the imager head are optional and available for purchase.
 2. This function is compatible with the MaxiVideo Digital Inspection Camera in models MV105S, MV108S, MV105, and MV108.
 3. Connect the tablet with MaxiVideo Digital Inspection Camera using the USB cable. For detailed operation instructions, please refer to the Quick Reference Guide for the MaxiVideo Digital Inspection Camera.
-

17 Quick Link

The Quick Link application provides you with convenient access to Autel's official website and many other well-known sites in automotive service industry to provide technical help, knowledge bases, forums, and training and expertise consultations.

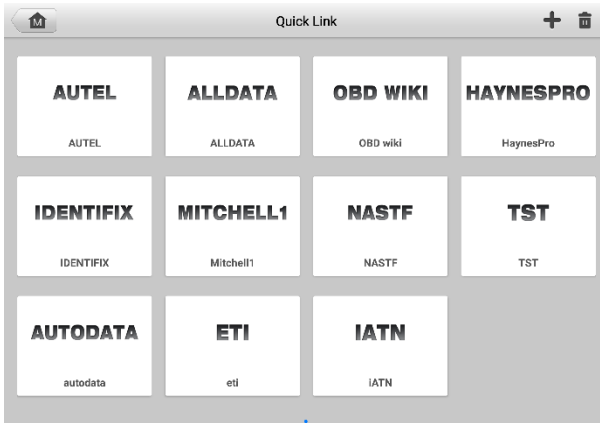

Figure 17-1 Quick Link Screen

➤ **To open a quick link**

1. Tap **Quick Link** on the MaxiSys Job Menu. The Quick Link application screen displays.
2. Select a website thumbnail from the main section. The Chrome browser is launched and the selected website is opened.

➤ **To manage the quick links**

1. Tap **Quick Link** on the MaxiSys Job Menu. The Quick Link application screen displays.
2. Tap the **+** icon on the upper-right corner to add websites. Tap the **🗑️** icon to delete websites.

18 Remote Desktop

The Remote Desktop application launches the TeamViewer Quick Support program, which is a simple, fast and secure remote-control interface. You can use the application to receive ad-hoc remote support from Autel's support center, colleagues, or friends, by allowing them to control your MaxiSys tablet on their PC via the TeamViewer software.

18.1 Operations

If you think of a TeamViewer connection as a phone call, the TeamViewer ID would be the phone number under which all TeamViewer Clients can be reached separately. Computers and mobile devices that run TeamViewer are identified by a globally unique ID. The first time the Remote Desktop application is started, this ID is generated automatically based on the hardware characteristics and will not change.

Make sure the tablet is connected to the Internet before launching the Remote Desktop application, so that the tablet is able to receive remote support from the third party.

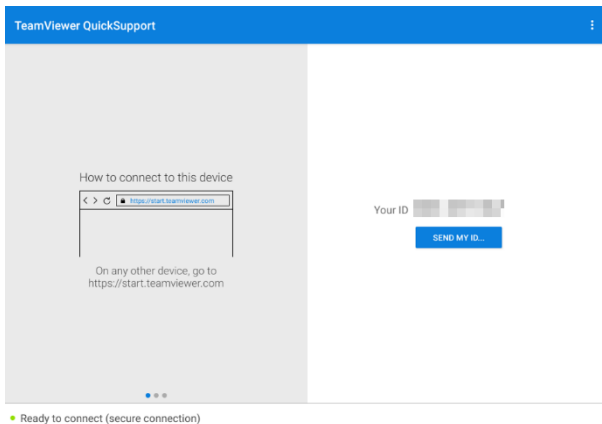

Figure 18-1 Remote Desktop Screen

➤ **To receive remote support from a partner**

1. Power on the tablet.
2. Tap the **Remote Desktop** application on the MaxiSys Job Menu. The TeamViewer interface displays and the device ID is generated and shown.
3. Your partner must install the Remote Control software to his/her computer by downloading the TeamViewer full version program online (<http://www.teamviewer.com>), and then launch the software.
4. Provide your ID to the partner, and wait for him/her to send you a remote-control request.
5. A message will appear asking for your confirmation to allow remote-control on your device.
6. Tap **Allow** to accept, or tap **Deny** to reject.

Refer to the associated TeamViewer documents for additional information.

19 User Feedback

The User Feedback application allows you to submit questions related to this product.

➤ **To send user feedback**

1. Tap **User Feedback** on the MaxiSys Job Menu. The device information is automatically synchronized.

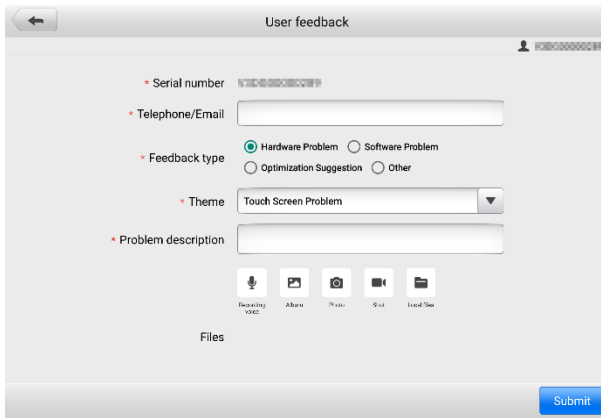

Figure 19-1 User Feedback Screen

2. Set **Telephone/Email**, **Feedback type**, **Theme**, and **Problem description**. You can also attach voice recordings, photos, screenshots, images or PDF files. To resolve your issue more efficiently, we recommend you to complete the information as many details as possible.
3. Tap **Submit** to send the completed information to Autel's online service center. The submitted feedback will be carefully read and handled by our service personnel.

20 Autel User Center

Software updates are available for free for the first year from the date of purchase. The Autel User Center application allows you to register your tool to download the latest released software, thereby enhancing the functionality of the MaxiSys application by adding new vehicle models or enhanced applications to the database.

There are two ways for product registration:

A. Via the MaxiSys tablet

➤ To log in with your account and register your Autel tool

1. Tap **Autel User Center** from the MaxiSys Job Menu. The following screen displays.

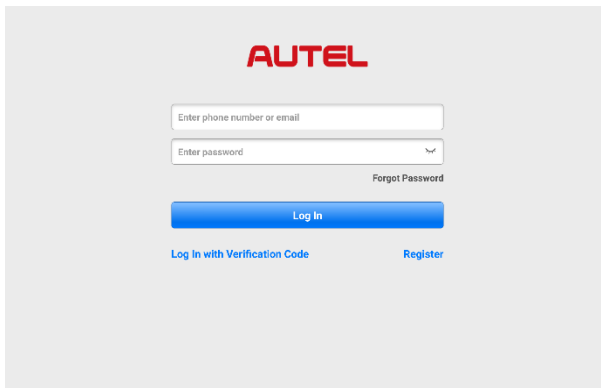

Figure 20-1 Autel User Center Screen

2. If you already have an Autel ID, you can log in with your phone number and verification code, or tap **Log In with Password** to log in with your Autel ID and password. If you don't have an Autel ID yet, tap **Register** to create an Autel ID.
3. Once your account is successfully registered, you will enter the main menu of the Autel User Center.
4. Select **Device Management** on the main menu.
5. Tap the **Link Device** button on the upper-right corner of the Device Management screen. The serial number and password of the device will automatically appear on the Link Device screen.

6. Tap the **Link** button to complete the product registration.

B. Via the Autel website

➤ **To register your Autel tool**

1. Visit the website: pro.autel.com.
2. If you have an Autel account, sign in with your account ID and password and skip to step 7.
3. If you are a new member to Autel, click the **Register** button to create your Autel ID.
4. Enter the required personal information in the input fields.
5. Enter your email address, then click **Request**. You will receive an email from Autel with your verification code. Open the email and copy the code into the proper input box.
6. Set a password for your account, and enter the password again to confirm. Read the **Autel User Service Agreement** and **Autel Privacy Policy**, then check the box to accept the terms. After all the information is entered, click **Register**. A Product Registration screen will appear.
7. Your product serial number and password are required to complete your registration. To find your serial number and password on the tool: go to **Settings > About**.
8. Enter your tool's serial number and password on the Product Registration screen. Enter the CAPTCHA code and click **Submit** to complete your registration procedure.

21 Maintenance and Service

To ensure that the tablet and the combined VCI unit perform at their optimum level, we advise that the product maintenance instructions covered in this section are strictly followed.

21.1 Maintenance Instructions

The following includes how to maintain your devices, together with precautions to take.

- Use a soft cloth and alcohol or a mild window cleaner to clean the touchscreen of the tablet.
- Do not use any abrasive cleansers, detergent, or automotive chemicals to the tablet.
- Keep the devices in dry conditions and within specified operating temperatures.
- Dry your hands before using the tablet. The touch screen of the tablet may not work if the touch screen is moist, or if you tap the touch screen with wet hands.
- Do not store the devices in humid, dusty or dirty areas.
- Check the housing, wiring, and connectors for dirt and damage before and after each use.
- Check the housing, wiring, and connectors for dirt and damage before and after each use.
- Do not attempt to disassemble your tablet or the VCI unit.
- Do not drop or cause severe impact to the devices.
- Use only authorized battery chargers and accessories. Any malfunction or damage caused by the use of unauthorized battery charger and accessories will void the limited product warranty.
- Ensure that the battery charger does not come in contact with conductive objects.
- Do not use the tablet beside microwave ovens, cordless phones and some medical or scientific instruments to prevent signal interference.

21.2 Troubleshooting Checklist

A. When the tablet does not work properly:

- Make sure the tablet has been registered online.
- Make sure the system software and diagnostic application software are properly updated.
- Make sure the tablet is connected to the Internet.
- Check all cables, connections, and indicators to see if the signal is being received.

B. When battery life is shorter than usual:

- This may happen when you are in an area with low signal strength. Turn off your device if it is not in use.

C. When you cannot turn on the tablet:

- Make sure the tablet is connected to a power source or the battery is charged.

D. When you are unable to charge the tablet:

- Your charger maybe out of order. Contact your nearest dealer.
- You may be attempting to use the device in an overly hot/cold temperature. Charge the device in a cooler or warmer area.
- Your device may have not been connected to the charger properly. Check the connector.

NOTE

If the problems persist, please contact Autel's technical support personnel or your local selling agent.

21.3 About Battery Usage

Your tablet is powered by a built-in lithium-ion polymer battery, which enables you to recharge your battery when there is electricity left.

DANGER

The built-in Lithium-ion Polymer battery is factory replaceable only; incorrect replacement or tampering with the battery pack may cause an explosion.

- Do not use a damaged battery charger.
- Do not disassemble, open, crush, bend, deform, puncture, or shred the battery.
- Do not modify, remanufacture or attempt to insert foreign objects into the battery, or expose the battery to fire, explosion, or other hazards.
- Only use the specified charger and USB cables. Use of non-Autel-authorized charger or USB cables may lead to device malfunction or failure.
- Use of an unqualified battery or charger may present a risk of fire, explosion, leakage, or other hazards.
- Avoid dropping the tablet. If the tablet is dropped, especially on a hard surface, and you suspect damage, take the tablet to a service center for inspection.
- Try to keep closer to your wireless router to reduce battery usage.
- The time needed to recharge the battery varies depending on the remaining battery capacity.
- Battery life inevitably shortens over time.
- Unplug the charger once the tablet is fully charged since overcharging may shorten battery life.
- Keep the battery in temperate environments. Do not place it inside a car when it is too hot or too cold, which may reduce the capacity and life of the battery.

21.4 Service Procedures

This section provides information on technical support, repair service, and application for replacement or optional parts.

21.4.1 Technical Support

If you have any question or problem on the operation of the product, please contact us.

Autel China Headquarters

- **Phone:** +86 (0755) 8614-7779 (Monday-Friday, 9AM-6PM Beijing Time)
- **Email:** support@autel.com
- **Address:** Floor 2, Caihong Keji Building, 36 Hi-tech North Six Road, Songpingshan Community, Xili Sub-district, Nanshan District, Shenzhen City, China
- **Web:** www.autel.com

Autel North America

- **Phone:** 1-855-288-3587 (Monday-Friday, 9AM-6PM Eastern Time)
- **Email:** ussupport@autel.com
- **Address:** 36 Harbor Park Drive, Port Washington, New York, USA 11050
- **Web:** www.autel.com/us

Autel Europe

- **Phone:** +49(0)89 540299608 (Monday-Friday, 9AM-6PM Berlin Time)
- **Email:** support.eu@autel.com
- **Address:** Landsberger Str. 408, 81241 München, Germany
- **Web:** www.autel.eu

Autel APAC

Japan:

- **Phone:** +81-045-548-6282
- **Email:** support.jp@autel.com
- **Address:** 6th Floor, Ari-nadoribiru 3-7-7, Shinyokohama, Kohoku-ku, Yokohama-shi, Kanagawa-ken, 222-0033 Japan
- **Web:** www.autel.com/jp

Australia:

- **Email:** ausupport@autel.com
- **Address:** Unit 5, 25 Veronica Street, Capalaba

Autel IMEA

- **Phone:** +971 585 002709 (in UAE)
- **Email:** imea-support@autel.com
- **Address:** 906-17, Preatoni Tower (Cluster L), Jumeirah Lakes Tower, DMCC, Dubai, UAE
- **Web:** www.autel.com

Autel Latin America

Mexico:

- **Phone:** +52 33 1001 7880 (Spanish in Mexico)
- **Email:** latsupport@autel.com

- **Address:** Avenida Americas 1905, 6B, Colonia Aldrete, Guadalajara, Jalisco, Mexico

Brazil:

- **Email:** brsupport@autel.com
- **Address:** Avenida José de Souza Campos n° 900, sala 32 Nova Campinas Campinas – SP, Brazil
- **Web:** www.autel.com/br

21.4.2 Repair Service

If it becomes necessary to return your device for repair, please download the repair service form from www.autel.com, and fill in the form. The following information must be included:

- Contact name
- Return address
- Telephone number
- Product name
- Complete description of the problem
- Proof-of-purchase for warranty repairs
- Preferred method of payment for non-warranty repairs

 **NOTE**

For non-warranty repairs, payment can be made with Visa, Master Card, or with approved credit terms.

Send the device to your local agent, or to the address below:

Floor 2, Caihong Keji Building, 36 Hi-tech North Six Road, Songpingshan Community, Xili Sub-district, Nanshan District, Shenzhen City, China

21.4.3 Other Services

You can purchase the optional accessories directly from Autel's authorized tool suppliers, and/or your local distributor or agent.

Your purchase order should include the following information:

- Contact information
- Product or part name
- Item description
- Purchase quantity

22 Compliance Information

FCC Compliance

FCC ID: WQ8-DV2141

This device complies with Part 15 of the FCC Rules. Operation is subject to the following two conditions:

1. This device may not cause harmful interference.
2. This device must accept any interference received, including interference that may cause undesired operation.

WARNING

Changes or modifications not expressly approved by the party responsible for compliance would void the user's authority to operate the equipment.

This equipment has been tested and found to comply with the limits for a Class B digital device, pursuant to Part 15 of the FCC Rules. These limits are designed to provide reasonable protection against harmful interference in a residential installation.

This equipment generates uses and can radiate radio frequency energy and, if not installed and used in accordance with the instructions, may cause harmful interference to radio communications. However, there is no guarantee that interference will not occur in a particular installation. If this equipment does cause harmful interference to radio or television reception, which can be determined by turning the equipment off and on, the user is encouraged to try to correct the interference by one or more of the following measures:

- Reorient or relocate the receiving antenna.
- Increase the separation between the equipment and receiver.
- Connect the equipment into an outlet on a circuit different from that to which the receiver is connected.
- Consult the dealer or an experienced radio/TV technician for help.

RF Warning Statement

The device has been evaluated to meet general RF exposure requirement. The device can be used in portable exposure condition without restriction.

IC Warning

This device complies with Industry Canada's licence-exempt RSS standard(s). Operation is subject to the following two conditions:

- (1) This device may not cause interference, and
- (2) This device must accept any interference, including interference that may cause undesired operation of the device.

Le présent appareil est conforme aux CNR d'Industrie Canada applicables aux appareils radio exempts de licence. L'exploitation est autorisée aux deux conditions suivantes:

- (1) l'appareil n' doit pas produire de brouillage, et
- (2) l'utilisateur de l'appareil doit accepter tout brouillage radioélectrique subi, même si le brouillage est susceptible d'en compromettre le fonctionnement.

SAR

The radiated output power of this device is below the FCC radio frequency exposure limits. Nevertheless, the device should be used in such a manner that the potential for human contact is minimized during normal operation.

The exposure standard for wireless devices employs a unit of measurement known as the Specific Absorption Rate, or SAR. The SAR limit set by the FCC is 1.6 W/Kg. Tests for SAR are conducted using standard operating positions accepted by the FCC with the device transmitting at its highest certified power level in all tested frequency bands. Although the SAR is determined at the highest certified power level, the actual SAR level of the device while operating can be well below the maximum value. This is because the device is designed to operate at multiple power levels so as to use only the power required to reach the network. To avoid the possibility of exceeding the FCC radio frequency exposure limits, human proximity to antenna should be minimized.

CE Compliance

RED Directive 2014/53/EU.

RoHS Compliance

This device is declared to be in compliance with the European RoHS Directive 2011/65/EU.

23 Warranty

12-Month Limited Warranty

Autel Intelligent Technology Corp., Ltd. (the Company) warrants to the original retail purchaser of this MaxiSys Diagnostic tablet that should this product or any part thereof during normal usage and under normal conditions be proven defective in material or workmanship that results in product failure within twelve (12) months period from the date of purchase, such defect(s) will be repaired, or replaced (with new or rebuilt parts) with Proof of Purchase, at the Company's option, without charge for parts or labor directly related to the defect(s).

NOTE

If the warranty period is inconsistent with local laws and regulations, please comply with the relevant local laws and regulations.

The Company shall not be liable for any incidental or consequential damages arising from the use, misuse, or mounting of the device. Some states do not allow limitation on how long an implied warranty lasts, so the above limitations may not apply to you.

This warranty does not apply to:

- a) Products subjected to abnormal use or conditions, accident, mishandling, neglect, unauthorized alteration, misuse, improper installation or repair or improper storage;
- b) Products whose mechanical serial number or electronic serial number has been removed, altered or defaced;
- c) Damage from exposure to excessive temperatures or extreme environmental conditions;
- d) Damage resulting from connection to, or use of any accessory or other product not approved or authorized by the Company;
- e) Defects in appearance, cosmetic, decorative or structural items such as framing and non-operative parts.
- f) Products damaged from external causes such as fire, dirt, sand, battery leakage, blown fuse, theft or improper usage of any electrical source.

! **IMPORTANT**

All contents of the product may be deleted during the process of repair. You should create a back-up copy of any contents of your product before delivering the product for warranty service.

AUTEL[®]