

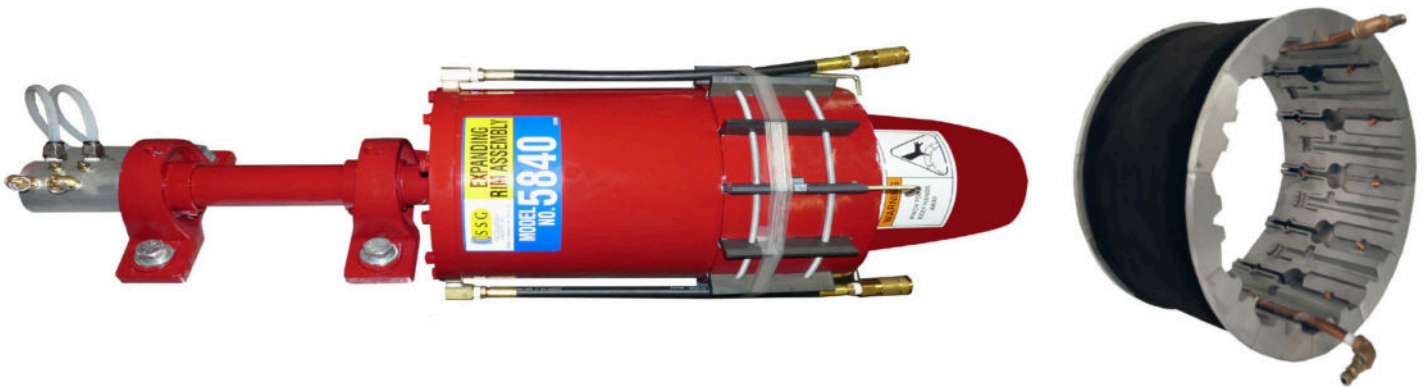

TIRE SERVICE INTERNATIONAL

TROUBLESHOOTING & MAINTENANCE GUIDE



EXPANDING HUB & RIM ASSEMBLIES

08.05.2015

HOW THE EXPANDING HUB WORKS

Compressed air is introduced to the expanding hub assembly via an “air swivel”. Air pressure is directed either to the expanding hub cylinder or to the expanding rim. Air flow and pressure is controlled by air valves and regulators located on the control panel of the machine.

THE OUTER HOUSING

The outer housing is a steel casting with twelve (12) slotted openings. The slotted openings allow for placement of stems which are used to expand the various expanding rims that work in conjunction with the expandable hub. The outer housing serves as the slide chamber (cylinder) for the internal piston.

THE STEM COMPONENTS

The STEMS (paddles) are made of composite plastic. They are placed in the slotted openings of the outer housing with their bottom end resting on the internal piston. Two springs are threaded through the STEMS to hold them in place. The top side of each STEM slides snugly into the molded casting on the underside of each expanding rim. Four (4) of the STEMS are equipped with locking mechanisms. They are termed “locking paddles”. There are eight (8) other stems and they are termed “plain paddles”.

THE PISTON

The piston consists of a machined casting cone configuration. When moved forward by channeled air pressure the piston fills the outer housing cavity and pushes the stems outward. The stems in turn push the expanding rim to the desired rim size for tire bead seating. When the air pressure is released the piston returns to the closed position. The expanding rim collapses to its smallest rim diameter size allowing the operator to remove the tire.

HIGH PRESSURE SIDE

When activated, the “high side” of the air swivel channels air through a port and into a small diameter hollow tube known as the “guide” or transfer tube. The transfer tube is centered inside a larger diameter, hollow main shaft. The piston slides on the guide tube. The large end of the piston is sealed against the wall of the rear housing cylinder via a U-cup, and the net result is a pressurized system. When under “high side” pressure the piston moves forward towards the front of the assembly allowing air to pressurize the expanding hub.

LOW PRESSURE SIDE

When activated the “low side” of the air swivel directs air to the expanding rim. The low side pressure is used to fill a tire with air allowing the operator to check for leaks and other visible problems. **The low side pressure must always be released prior to releasing the high side air pressure to the expanding hub.**

TROUBLESHOOTING TIPS

PROBLEM: RIM AND OR HUB NOT EXPANDING PROPERLY

Possible Causes:

1. **INTERNAL HUB COMPONENTS LACKING LUBRICATION: Action Required:** Follow instructions for Expanding Hub Preventive Maintenance. Lubricate internal piston and shafts. Use Marine Grease TSI Part #10787.
2. **WORN EXPANDING RIM SEGMENTS: Action Required:** Check for excessive (more than .020) play in the locking slot with a locking stem. (Note: stem will fit properly only one way.) Return rim to TSISSG for Rim Reconditioning Services.
3. **U-CUP SEALS WORN: Action Required:** Follow instructions for Expanding Hub Preventive Maintenance to remove the expanding hub outer housing. Inspect u-cup on rear of piston for wear or damage. Replace if worn. Lubrication- lubricate rear housing cylinder surface, piston and guide tube with Marine Grease TSI Part #10787. (see attached Expanding Hub Preventive Maintenance Bulletin)
4. **BENT OR DAMAGED GUIDE TUBE: Action Required:** Follow instructions for Expanding Hub Preventive Maintenance to remove the expanding hub outer housing. Inspect guide tube for gouges, nicks or bends. Replace guide tube with appropriate part number for your assembly.
5. **INSUFFICIENT AIR PRESSURE: Action Required:** Verify air pressure coming into machine meets manufacture suggested minimum operation pressure and correct as necessary.
6. **WATER EXTRACTOR MALFUNCTIONING: Action Required:** Inspect internal water extractor for proper operation: Water extractor should be allowing air flow while removing excess moisture to vent from bottom of unit. Replace if extractor plugged.
7. **REGULATORS MALFUNCTIONING: Action Required:** Inspect regulator for proper operation. Adjust regulators to different pressures and verify pressure gauge changes. If regulator not adjusting replace regulator.
8. **AIR VALVE MALFUNCTIONING: Action Required:** Check to see if valve when opened is makes a "hissing" noise. Replace valve if leaking.
9. **KINKS IN AIR LINES: Action Required:** Inspect internal air lines for kinks. Correct as necessary.
10. **DAMAGED OR WORN PISTON: Action Required:** Follow instructions for Expanding Hub Preventive Maintenance to remove the expanding hub outer housing. Inspect piston for grooves, gouging and or excessive wear. Replace piston.
11. **AIR INLET HUB MISALIGNED: Action Required:** Inspect air inlet hub #4903 (opposite end of front housing). Air inlet hub (#4903) should slide on to main shaft (#5780). Air inlet when in correct position will slide forward towards the bearing housings with approximately 1/16" space between front of air inlet hub and shoulder on the main shaft (#5780). Once in the correct position the air inlet hub is held in place by an adjustable "L" bracket (#462.111)

PROBLEM: TIRE NOT SEATING AND/OR LEAKING AIR

Possible Causes:

1. **HUB NOT FULLY EXPANDING: Action Required:** Check incoming air pressure to machine (125lbs psi. minimum). Check regulated pressure to the "Hub" on front of machine. Adjust as needed but do NOT exceed 90lbs psi.
2. **BELT LACKING LUBRICATION: Action Required:** Lubricate belt with an approved oil soap. Caution: DO NOT USE SUBSTITUES AS BELT DETERIORATION WILL RESULT.
3. **INTERNAL HUB COMPONENTS LACKING LUBRICATION: Action Required:** Follow instructions for Expanding Hub Preventive Maintenance. Lubricate internal piston and shafts. Use Marine Grease TSI Part #10787.
4. **TIRE AIR PRESSUE INADEQUATE: Action Required:** Increase air pressure to "tire side" of machine to 30 to 32lbs psi. WARNING: DO NOT EXCEED 32lbs psi. When the tire seats regulate the pressure back to manufacture suggested pressure.
5. **WORN STEMS: Action required:** Check all stems for excessive wear and or bending. Replace all stems if worn.
6. **WORN PISTON: Action required:** Check for excessive wear, grooves, pitting, and or scuffing. Replace cone as needed.

NOTE: Some rims will leak air when the tire is mounted. Because of the nature of the rim design leakage cannot be prevented. Please accept some leakage as a normal situation.

PROBLEM: HUB AND OR RIM WILL NOT COLLAPSE

Possible Causes:

1. **BELT IS WORN: Action Required:** Inspect belt on expanding rim for excessive wear. Replace as needed.
2. **BELT LACKS LUBRICATION: Action Required:** Inspect belt for dryness. Lubricate as needed. Use oil soap.
3. **AIR REGULATOR MALFUNCTION: Action Required:** Inspect regulator for proper operation. Adjust regulators to different pressures and verify pressure gauge changes. If regulator not adjusting replace regulator.
4. **HUB IS DIRTY OR LACKS LUBRICATION: Action Required:** Follow instructions for Expanding Hub Preventive Maintenance. Lubricate internal piston and shafts. Use Marine Grease TSI Part #10787.

5. **WORN PISTON: Action required:** Check for excessive wear and or grooving. If pitted or scuffed, sand piston with 360 grit emery cloth, grease and reassemble. Replace cone as needed.

6. **BENT OR DAMAGED GUIDE TUBE: Action Required:** Follow instructions for Expanding Hub Preventive Maintenance to remove the expanding hub outer housing. Inspect guide tube for gouges, nicks or bends. Replace guide tube with appropriate part number for your assembly. See parts drawing.

7. **SLIDE PLATES DAMAGED: Action Required:** Inspect expanding rim for slide plate misalignment and or damage. Return to TSISSG for rim reconditioning.

NOTE: RIMS AND HUBS SHOULD BE KEPT AWAY FROM WATER

NOTE: The shop air supply to these machines should be equipped with an automatic water extractor to prevent water from entering the TSISSG #5840 Hub assembly. Water in the hub will prevent the machine from operating properly.

EXPANDING HUB PREVENTATIVE MAINTENANCE SERVICE BULLETIN

The TSISSG Hub assembly is designed and manufactured for long-term trouble-free operation. It is a time and labor saving unit that will deliver many years of service if a reasonable cleaning and maintenance schedule is practiced.

The purpose of this service bulletin is to show personnel how to perform simple procedures for maintaining the expanding hub assembly. Caution: Before performing any disassembly disconnect air supply to machine. Disconnect air hoses connected to the air swivel assembly.

EXPANDING RIMS

The expanding rim assembly is a flexible unit comprised of more than two dozen individual pieces, held together by a natural rubber belt. Due to the movable parts on these expanding rims caution must be taken in handling all rims. Rough handling can cause rims to come apart and or be damaged. (DO NOT DROP THE EXPANDING RIMS, THEY WILL COME APART. WARRANTY DOES NOT COVER REASSEMBLY OF THE RIMS)

Each segment or "shoe" is hand-fitted and then machined to precise tolerances. They are aluminum cast shoes and as such require much care when changing and transporting.

NOTE: Whenever a rim assembly appears to be sloppy or wobbles when placed on the floor, it is time to replace the belt. These, as well as all other parts, are available by calling TSISSG at 1-800-223-4540 or FAX at 1-602-437-5025.

General maintenance on these rims consists of blowing the dust or dirt off of the rubber belt periodically using about 50lbs to 75lbs air pressure. Keep the belt lightly lubricated with oil soap to prolong belt life. DO NOT USE GREASE OR ANY OTHER PETROLIUM BASED LUBRICANTS.

GENERAL MAINTENANCE

Please see the remaining pages of this guide or the DVD for detailed, step by step instructions.

The frequency in which these procedures are needed may depend on humidity and or moisture levels in your compressed air supply.

DO NOT use regular types of grease, Lubriplate, WD-40 on the Hub. Use only water resistant Marine Grease; TSI Part # 10787 or equivalent.

With a rim installed on hub assembly, cycle the hub and rim assemblies 12-20 times. This will allow the Marine Grease to work into all areas. The unit should cycle smoothly.

DAILY:

- Lube belt with oil soap tire lube as needed
- Check the four expandable rim locks to ensure they are in the locked position
- Look inside the hub to see the locking tab is engaged

WEEKLY:

In addition to the daily maintenance the following maintenance is recommended weekly.

- Detach 2 Air Supply Hoses and remove expandable rim
- Remove paddles
- Clean out the paddle slots using air pressure
- Use marine grease to lubricate the paddle slots
- Clean each paddle
- Lubricate the bottom of each paddle
- Reassemble
- Reinstall the rim, reconnect air hoses and locking tabs.
- Grease the main shaft- see detailed instructions

1-6 MONTH:

After completing the daily and weekly recommended maintenance the following procedures are recommended every 1-6 months.

- Remove the hub outer housing
- Remove internal cone
- Clean the inside of the housing cylinder- Use brake cleaner to remove grease residue. Follow with scotch bright pad
- Clean the cone- Use brake cleaner to remove grease residue. Follow with scotch bright pad.
- Lubricate the inside of the cylinder- Use marine grease
- Lubricate the outside of the cone-Use marine grease
- Lubricate the shaft
- Reassemble the Unit

EXPANDABLE HUB MAINTENANCE

The frequency in which these procedures are needed may depend on humidity and or moisture levels in your compressed air supply.

RIM LOCK MAINTENANCE

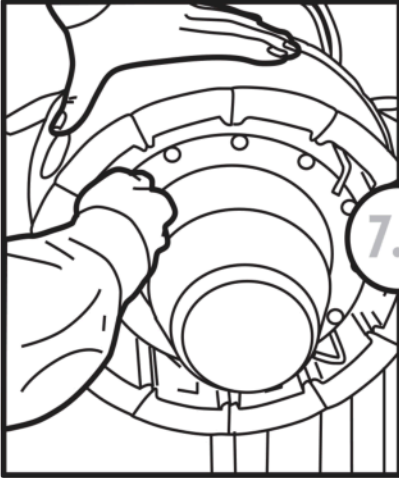

7.1

Check the four expandable rim locks to make sure they are locked into position. This involves physically feeling the locks to make sure they are turned counter clockwise

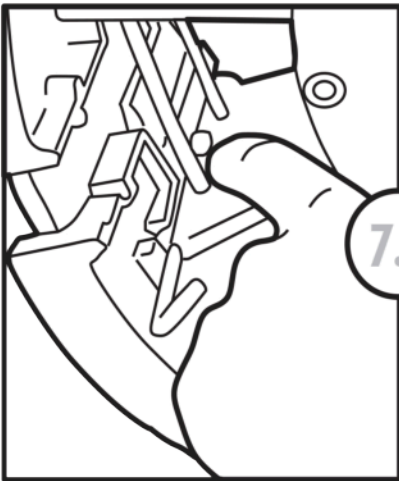

7.2

Place tire on rim. Expand your rim. Look in your hub to see the tab locking into the rim. Make sure that all four are locked into position.

WEEKLY PREVENTATIVE MAINTENANCE



7.3

Remove the expandable rim [1 of 2]

Remove your expandable rim by first detaching the 2 air supply hoses.

Continue by unlocking the tabs and pulling on the rim to remove. Carefully set expanding rim aside.

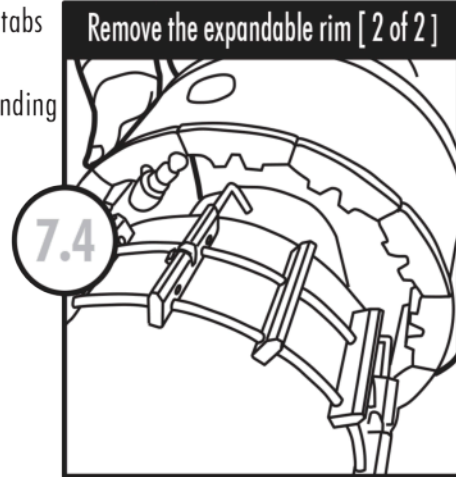

7.4

Remove the expandable rim [2 of 2]

Disconnect one of the two springs (rear one recommended) and gently remove the spring by pulling it out of the paddles. Set the spring aside.

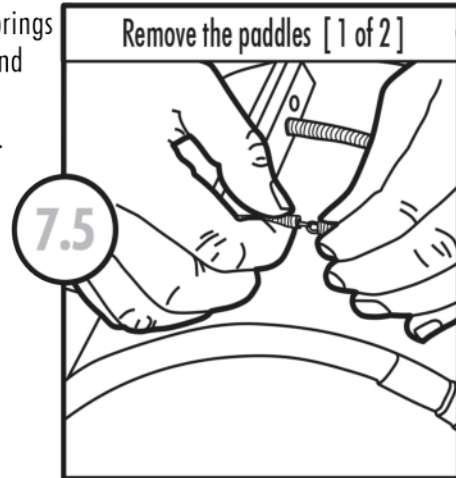

7.5

Remove the paddles [1 of 2]

Remove your paddles one at a time by pulling straight up until they're completely out of the paddle slot.

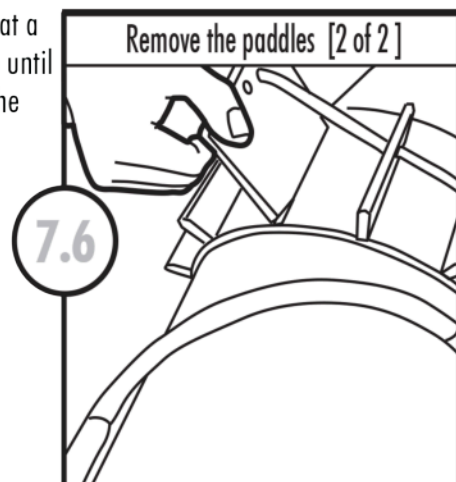

7.6

Remove the paddles [2 of 2]

EXPANDABLE HUB MAINTENANCE

Remove the paddles [3 of 4]

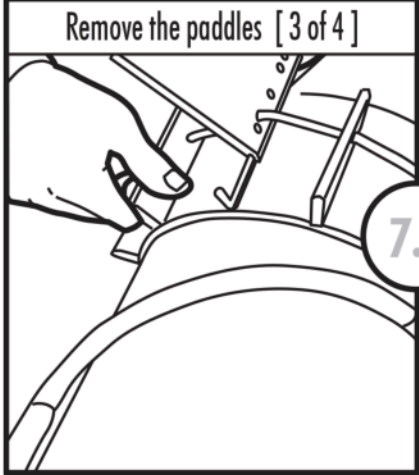

Turn the paddle 180 degrees allowing the spring side to rest on the hub before continuing on to remove the next paddle. This will make removing the ring of paddles from the hub easier.

Remove the paddles [4 of 4]

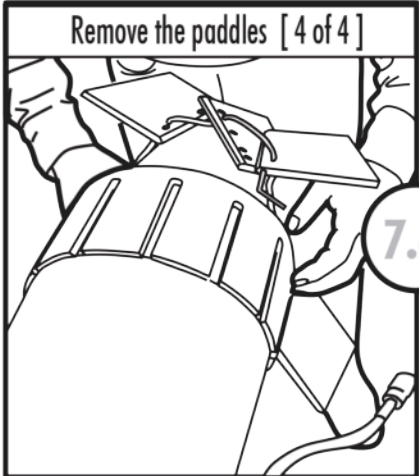

Once all the paddles are removed pull the collection gently away from the hub making sure to free any of the paddles that may get bound up by the locking pins

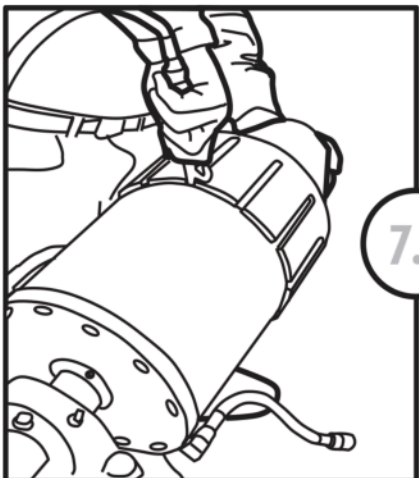

Using an air hose blow compressed air directly into the open paddle slots giving an approximate 2 - 3 second blast deep inside the slot working the hose side to side. This will help dislodge and expel any dirt or debris that may have collected in the hub. Insert your air hose into every other slot for sufficient air distribution.



Only use a Marine base wheel grease such as TSI PN 10787.

Using a marine base wheel grease apply a film of grease to each slot of the hub.

NEVER USE AN OIL BASED LUBRICANT

Turn the hub to advance to the next open slot and repeat until all slots have been lubricated.



A pair of rubber gloves can come in handy when installing the paddles.

Carefully clean each paddle and the two springs before installing them. The paddles must be free of dirt and debris.

If rough areas are present remove them using a 3M Scotch Brite pad.

Install the paddles [1 of 7]

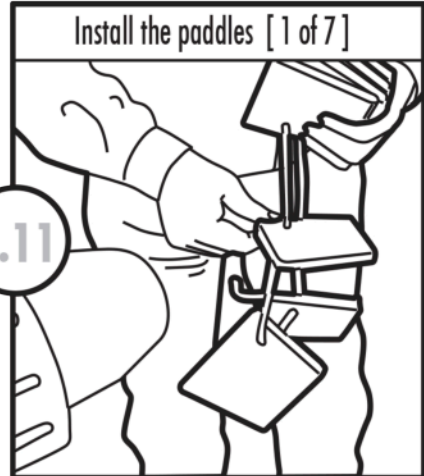

The slanted surface on each paddle inserts into the slots and ride against the cone within the hub.

Apply an even film of marine base wheel bearing grease on the slanted surface of each paddle.

Install the paddles [2 of 7]

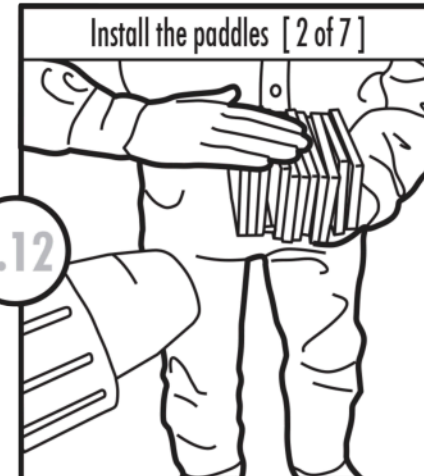

EXPANDABLE HUB MAINTENANCE

Install the paddles [3 of 7]

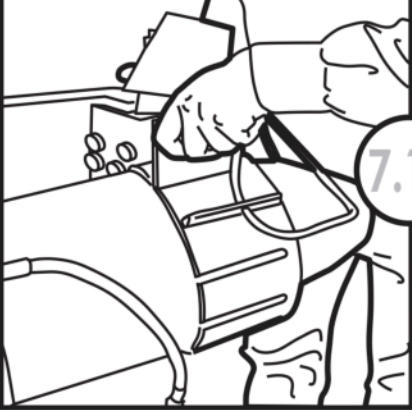

7.13

Two at a time, begin inserting the paddles into the hub. Align the paddles so that the slanted (greased) side rests inside the hub. The narrower portion of the paddle slides in nearest the rear of the hub. The longer portion nearer to you.

Install the paddles [4 of 7]

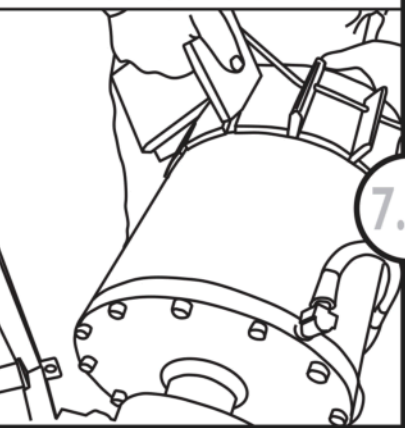

7.14

Install the paddles [5 of 7]



7.15

Now insert the rear spring into the outer holes and thread the spring through each paddle.

Eventually reattaching the spring ends when they meet.

Install the paddles [6 of 7]

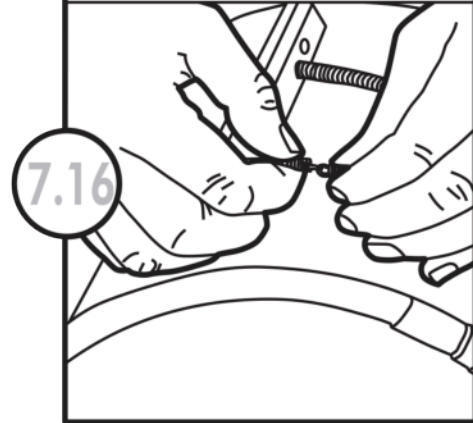

7.16

Once the spring is reattached check to make sure the locking tabs are UNLOCKED.

Install the paddles [7 of 7]

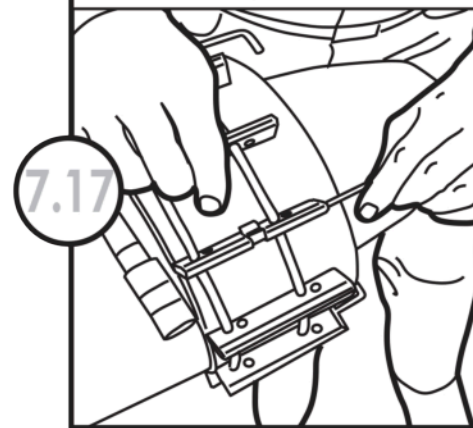

7.17

After putting in the springs and paddles the photo below shows what the completed assembly will look like.



EXPANDABLE HUB MAINTENANCE



Physically and visibly check to ensure the locking pins are **LOCKED** and secure before deflating the rim.

Install the expandable rim [1 of 2]

Reinstall the rim onto the hub making sure that the airline couplers on the rim are facing the airlines on the hub.

7.20

STE-M

Also check the tightness of axle set screws located on the expandable hub. Deliver 1 shot of chassis lube to the sealed bearing on the expandable hub axle.

7.23

TI-95

Grease the machine through the hole in the back of unit with standard chassis grease every 30 days or as needed.

Install the expandable rim [2 of 2]

The rim must be positioned so that when the hub air hoses are connected, they have as much slack as possible to accommodate the distance require for expanding.

7.21

1 - 6 MONTH PREVENTATIVE MAINTENANCE

Remove the expandable rim (Refer to Figures 7.3 - 7.4)

Remove the paddles (Refer to Figures 7.5 - 7.9)

Remove the expandable rim & paddles before performing the following procedures.

Take the front cover of the hub off by loosening the cover screws but leaving them seated in the holes.

7.24

LOCK the locking tabs on the rim. Place tire on rim and expand your rim.

7.22

Once all the screws are completely loosened pull the hubs cover away from the hub about 6 - 8 inches. Then remove the loosened hub cover screws completely and set them aside.

7.25

EXPANDABLE HUB MAINTENANCE

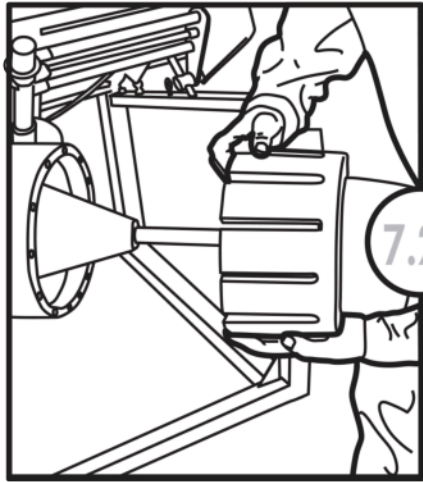

7.26 Pull the outer housing away, taking care not to bend the inner shaft. The inner shaft can be removed with the housing. Once the housing and shaft is pulled out completely gently set it aside and remove the cone.

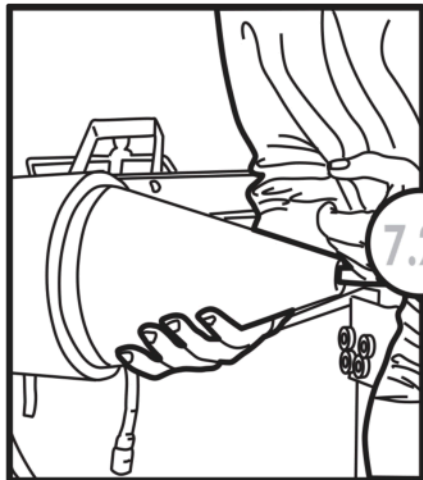

7.27 To remove the cone insert a finger into the shaft opening of the cone (being careful not to injure yourself) and with the other hand grasp the cone and gently work the cone out of the hub chamber. You may need to gently work the cone up and down as you pull the cone out. Be careful not to drop the cone it may come out unexpectedly.

Set the cone on the base with cone pointing upward.

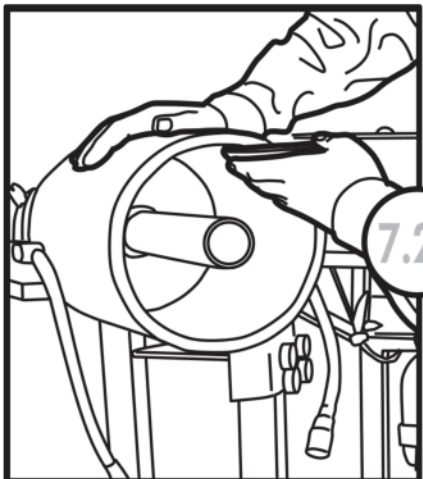

Using a brake cleaner wash and wipe out any grease, oil or buildup that may be on the inside of the cylinder.

7.28 Using a 3M Scotch Brite pad or emery paper gently rub the inner walls of the hub chamber removing any loose dirt or debris. Polishing the inside will help remove any possible corrosion. The finished walls should feel ultra smooth

The cone will also need to be smoothed out by the same method. With the cone placed on the ground (cone pointing upward) use the same type of pad to smooth the outer surface of the cone. The paddles have made contact with this surface. Apply special attention to these areas to ensure they are very smooth to the touch.

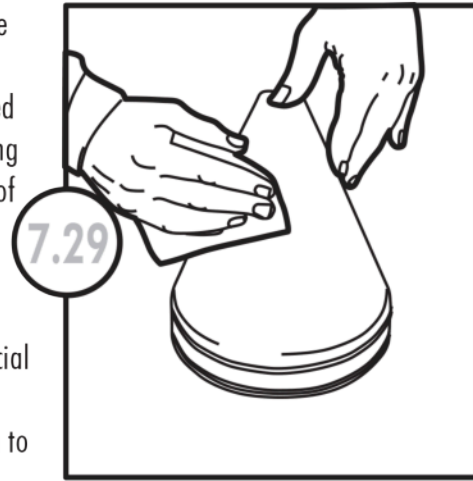

Once the cone surface is clean and smoothed, pick up the cone turning it on its side and resting it on a towel or soft surface like your lap or knee. Then smooth the flat outer surface where the rubber seal is.

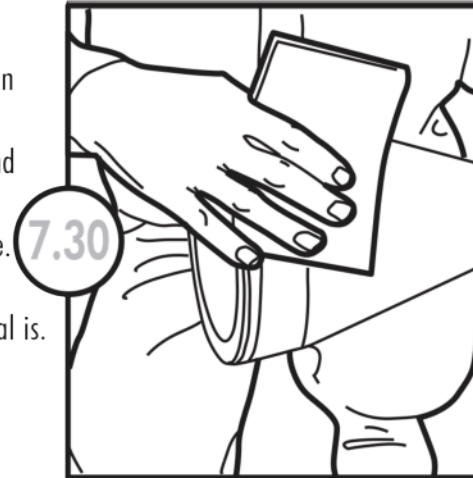

Inspect the rubber seal itself feeling for cracks and defects. If defects do appear in the large outer rubber seal or in either one of the small inner seals (at the tapered end of the cone) then contact us to obtain a seal kit to replace the defective seal.

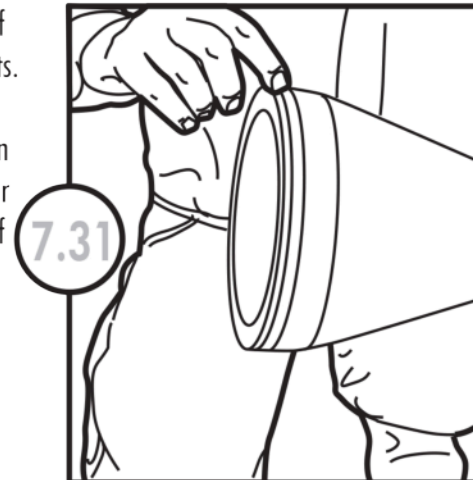

Lubricate the outer surface of the cone with a film of marine grease.



EXPANDABLE HUB MAINTENANCE



Only use a Marine base wheel bearing grease such as TSI PN 10787.

Lubricate the inside of the hub chamber as well. Apply an even film of marine base wheel bearing grease.

7.33

Insert the cone into the hub chamber (tapered end facing you). Picking the cone up by inserting a finger (being careful not to injure yourself) into the top of the hub and supporting the weight of the cone by the other hand at the base will help keep the lube coating remain.

7.34

Now reinstall the cone. To reinstall the cone carefully align the outer base with the hub chamber opening.

7.35

Holding the tapered end securely, begin to apply pressure to the larger outer rubber O-ring located at the base of the cone. This O-ring will form an air tight seal thus it will be a tight fit. The O-ring must be compressed allowing the cone to seat inside the hub chamber.

7.36

Once the cone is chambered. Replace the housing and inner shaft and tighten screws. Replace paddles by reversing procedure in Figure 7.5-7.9

7.37

Reinstall the rim onto the hub making sure that the airline couplers on the rim are facing the airlines on the hub.

7.38

The rim must be positioned so that when the hub air hoses are connected, they have as much slack as possible to accommodate the distance require for expanding.

7.39

Install the expandable rim [1 of 2]

Install the expandable rim [2 of 2]