

9APF / 12APF Two-Post Lift Series

Installation and Operation Manual

Manual P/N 5900388—Revision A — July 2025

Models:

- **9APF**
- **12APF**

*Original Instructions in
the English language.*



9APF shown with optional equipment.

12APF shown with optional equipment.

DANGER

IMPORTANT SAFETY INSTRUCTIONS, SAVE THESE INSTRUCTIONS! Read the entire contents of this manual **before** using this product. Failure to follow the instructions and safety precautions in this manual can result in serious injury or death. Make sure all other operators also read this manual. Keep the manual near the product for future reference. **By proceeding with setup and operation, you agree that you fully understand the contents of this manual and assume full responsibility for product use.**

Manual. 9APF / 12APF Two-Post Lifts, *Installation and Operation Manual*, Part Number 5900388, Revision A, released July 2025.

Copyright. Copyright © 2025 by BendPak Inc. All rights reserved. You may make copies of this document if you agree that: full attribution goes to BendPak Inc., you are not authorized to make changes to the content, you do not gain any rights to this content, and you will not use the copies for commercial purposes.

Trademarks. BendPak and the BendPak logo are registered trademarks of BendPak Inc. All other company, product, and service names are used for identification only. All trademarks and registered trademarks mentioned in this manual are the property of their respective owners.

Limitations. Every effort has been made to ensure complete and accurate instructions are included in this manual. However, product updates, revisions, and/or changes may have occurred since this manual was published. BendPak reserves the right to change any information in this manual without incurring any obligation for equipment previously or subsequently sold. All drawings are reference only – do not scale. BendPak is not responsible for typographical errors in this manual. You can always find the latest version of the **manual for your product on the BendPak website**.



Warranty. The BendPak warranty is more than a commitment to you: it is also a commitment to the value of your new product. Contact your nearest BendPak dealer or visit www.bendpak.com/support/warranty for full warranty details.

Safety. Your Lift was designed and manufactured with safety in mind. Your safety also depends on proper training and thoughtful operation. Do not set up, operate, maintain, or repair the Lift without reading and understanding this manual and the labels on the unit; **do not use your Lift unless you can do so safely!**

Owner Responsibility. In order to maintain your product properly and to ensure operator safety, it is the responsibility of the product owner to read and follow these instructions:

- Follow all installation, operation, and maintenance instructions.
- Make sure product installation conforms to all applicable local, state, and federal codes, rules, and regulations, such as state and federal OSHA regulations and electrical codes.
- Read and follow all safety instructions. Keep them readily available for operators.
- Make sure all operators are properly trained, know how to safely operate the unit, and are properly supervised.
- Do not operate the product until you are certain all parts are in place and operating correctly.
- Carefully inspect the product on a regular basis and perform all maintenance as required.
- Service and maintain the unit only with approved replacement parts.
- Keep the manual with the product and make sure all labels are clean and visible.
- **BendPak** makes no promises, guarantees or assurances that our products meet any state, county, federal or international mandated permit, license, code, standard, certification, or any other mandate other than what is listed or shown on BendPak website(s), or any BendPak online or published catalog. Not all BendPak lift models meet the standards as prescribed by ANSI/ALI ALCTV-(current edition) or ANSI/UL 201. Consult www.autolift.org for a complete list of lift models that meet ANSI/ALI ALCTV-(current edition) or ANSI/UL 201, or contact BendPak via www.bendpak.com/contact/ **Buyer assumes full responsibility for any state, county, federal or international mandated permit, license, code, standard, certification, or any other mandate required related to the installation and/or operation of any BendPak product.** BendPak will not be responsible for any charges, fines, liens, or other levies imposed on the Buyer related to any special or regional structural, seismic or any other building code and/or codes such as the Uniform Building Code (UBC), International Building Code (IBC), or any other state, county, federal or international mandated permit, license, code, standard, certification, or other mandate, law, rule, regulation or directive by any other agency, government, administrations, or corporations whether state, county, federal, or international mandated.
- **Only use the Lift if it can be used safely!**

Unit Information. Enter the Model Number, Serial Number, and the Date of Manufacture from the ID label on your unit. This information is required for part or warranty issues.

Model: _____

Serial: _____

Date of Manufacture: _____

Designed and engineered by BendPak Inc. in Southern California, USA. Made in China.



9APF shown with optional equipment.



12APF shown with optional equipment.

Table of Contents

Introduction	4	Operation	63
Shipping Information	5	Maintenance	72
Safety Considerations	5	Troubleshooting	78
FAQ	8	Wiring Diagrams	81
Components	9	Labels	82
Specifications	11	Parts Drawings	85
Installation Checklist	15	ALI Store	106
Installation	16	Maintenance Log	107

Introduction

This manual describes the following Two-Post Lift models:

- **9APF** Two-Post Surface Mount Service Lift with a 9,000 lb. (4,082 kg) capacity.
- **12APF** Two-Post Surface Mount Service Lift with a 12,000 lb. (5,443 kg) capacity.

These models are similar, and if no distinction is made, then the information applies to both models. If information applies to only one model, that distinction is *clearly denoted* in the text.

More information about the full line of BendPak products is available at bendpak.com.

⚠ DANGER Be very careful when installing, operating, maintaining, or repairing this equipment; failure to do so could result in property damage, product damage, injury, or (in very rare cases) death. Make sure only authorized personnel operate this equipment. An authorized technician must perform all repairs. Do not make modifications to the Lift; this voids the warranty and increases the chances of injury or property damage. Make sure to read and follow the instructions on the labels on the unit.

This manual is mandatory reading for all users of 9APF and 12APF Lifts, including anyone who installs, operates, maintains, or repairs them. Always keep this manual on or near the equipment.

Technical support and service is available from your dealer, on the Web at bendpak.com/support, by email at support@bendpak.com, or by phone at **(800) 253-2363** follow the prompts to reach support.

Online chat is also available at www.bendpak.com click the chat icon.



Scan this QR Code for up-to-date information and videos on BendPak Lifts.



Shipping Information

Your equipment was carefully checked before shipping. Nevertheless, you should thoroughly inspect the shipment **before** you sign to acknowledge that you received it.

When you sign the bill of lading, it tells the carrier that the items on the invoice were received in good condition. **Do not sign the bill of lading until after you have inspected the shipment.** If any of the items listed on the bill of lading are missing or damaged, do not accept the shipment until the carrier makes a notation on the bill of lading that lists the missing or damaged goods.

If you discover missing or damaged goods **after** you receive the shipment and have signed the bill of lading, notify the carrier at once and request the carrier to make an inspection. If the carrier will not make an inspection, prepare a signed statement to the effect that you have notified the carrier (on a specific date), and that the carrier has failed to comply with your request.

It is difficult to collect for loss or damage after you have given the carrier a signed bill of lading. If this happens to you, file a claim with the carrier promptly. Support your claim with copies of the bill of lading, freight bill, invoice, and photographs, if available. Our willingness to assist in helping you process your claim does not make us responsible for collection of claims or replacement of lost or damaged materials.

Safety Considerations

Read this entire manual carefully before using your new product. Do not install or operate the product until you are familiar with all operating instructions and warnings. Refer to ANSI/ALI ALIS Standard *Safety Requirements for Installation and Service of Automotive Lifts* for more information about safely installing your Lift.

 **WARNING** **California Proposition 65.** This product can expose you to chemicals including styrene and vinyl chloride which are on the list of over 900 chemicals identified by the State of California to cause cancer, birth defects or reproductive harm. **ALWAYS** use this product in accordance with BendPak's instructions. For more information go to www.P65Warnings.ca.gov.

 **WARNING** BendPak does not supply hydraulic fluid or lubricants with this lift. Always refer to the Material Safety Data Sheet (MSDS) for safe handling and disposal information. MSDS are available from the hydraulic fluid or lubricant's supplier or manufacturer.

IMPORTANT SAFETY INSTRUCTIONS!

Save these instructions!

1. Read all instructions.
2. Care must be taken as burns can occur from touching hot parts.
3. Do not operate equipment with a damaged cord or if the equipment has been dropped or damaged – until a qualified service person has examined it.
4. Do not let a cord hang over the edge of a table, bench, or counter or come into contact with hot manifolds or moving fan blades.

-
5. If an extension cord is necessary, a cord with a current rating equal to or more than that of the equipment should be used. Cords with a current rating less than the equipment may overheat. Care should be taken to arrange the cord so that it will not be tripped over or pulled.
 6. Always unplug the equipment from the electrical outlet when not in use. Never use the cord to pull the plug from the outlet. Grasp the plug and pull to disconnect.
 7. Let the equipment cool completely before putting away. Loop cord loosely around equipment when storing.
 8. To reduce the risk of fire, do not operate in the vicinity of open containers of flammable liquids (gasoline); this device is not intrinsically safe. Internal Arcing may ignite combustible gases.
 9. Adequate ventilation should be provided when working on operating internal combustion engines.
 10. Keep hair, loose clothing, fingers, and all parts of body away from moving parts.
 11. To reduce the risk of electric shock, do not use on wet surfaces or expose to rain.
 12. Use only as described in this manual. Use only BendPak recommended attachments.
 13. ALWAYS WEAR SAFETY GLASSES. Everyday eyeglasses only have impact resistant lenses, they are not safety glasses.
 14. To reduce the risk of injury, close supervision is necessary when this product will be used around children.
 15. To reduce the risk of injury, **never** attempt to lift more than the rated capacity. Refer to loading instructions.
 16. The Lift uses electrical energy; if your organization has Lockout/Tagout policies, make sure to implement them after connecting the Lift to a power source.
 17. Refer to markings for proper load on electrical receptacles.
 18. Only operate your Lift between temperatures of +41°F to +104°F (+5°C to +40°C).
 19. The Lift should **only** be operated by authorized personnel. Keep children and untrained personnel away from the Lift.
 20. Do not make any modifications to the Lift; this voids the warranty and increases the chances of injury or property damage.
 21. Do not use the Lift while tired or under the influence of drugs, alcohol, or medication.
 22. Consider the work environment. Keep the work area clean. Cluttered work areas invite injuries. Keep areas well lit.
 23. **Always** make sure the Lift is secured on Safety Locks before attempting to work on or near a vehicle.
 24. Make a thorough inspection of the product at least once a year. Replace any damaged or severely worn parts, decals, or warning labels. Replace worn or damaged parts with BendPak or BendPak approved parts and assemblies only.
 25. BendPak recommends referring to the ANSI/ALI ALIS Standard *Safety Requirements for Installation and Service* for more information about safely installing, using, and servicing your Lift.
 26. **9APF** and **12APF** Lifts are Two-Post Service Lifts. **Use them only for their intended purpose.**
 27. You **must** wear OSHA-approved (publication 3151) personal protective equipment at all times when installing, using, maintaining, or repairing the Lift. Leather gloves, steel-toed work boots, eye protection, back belts, and hearing protection are **mandatory**.

-
28. Keep loads balanced on the Lift Arms. Clear the area immediately if a Vehicle is in danger of falling off the Lift. Do not make any modifications to the Lift.
 29. Modifications void the warranty and increase the chances of injury or property damage. *Do not modify any safety-related features in any way.*
 30. Make sure all operators read and understand this Installation and Operation Manual. *Keep the manual near the Lift at all times.*
 31. While handling a Hydraulic Cylinder or a Hydraulic Hose, **always** wear gloves. In rare cases, a needle-like stream of hydraulic fluid (even at low pressure) can penetrate fingers, hands, or arms; such a puncture can feel like a bite, electric shock, or a prick. While it may *seem* like a minor issue, any amount of Hydraulic Fluid injected into the human body is a serious issue. Anyone suffering such a puncture wound should be **immediately** taken to a hospital emergency room to determine the extent of the injury. Explain the circumstances of the injury to the attending physician, including what kind of Hydraulic Fluid was involved. Do not assume a puncture wound that could have been caused by Hydraulic Fluid is a minor issue; it could be life threatening.
 32. Make an inspection of the Lift **before** using it. Check for damaged, worn, or missing parts. Do not use it if you find any of these issues. Instead, take it out of service, then contact an authorized repair facility, your dealer, or BendPak at **(800) 253-2363**, then follow the prompts. support@BendPak.com.

 **DANGER** Always refer to the lubricant and hydraulic fluid manufacturer's Material Safety Data Sheet (MSDS) for proper handling and disposal of chemicals.

Symbols

Following are the symbols used in this manual:

 **DANGER** Calls attention to an immediate hazard that **will** result in injury or death.

 **WARNING** Calls attention to a hazard or unsafe practice that **could** result in injury or death.

 **CAUTION** Calls attention to a hazard or unsafe practice that could result in minor personal injury, product, or property damage.

NOTICE Calls attention to a situation that, if not avoided, could result in product or property damage.



Calls attention to information that can help you use your product better.

Liability Information

BendPak Inc. assumes **no** liability for damages resulting from:

- Use of the product for purposes other than those described in this manual.
- Modifications to the equipment without prior, written permission from BendPak Inc.
- Injury or death caused by modifying, disabling, overriding, or removing safety features.
- Damage to the equipment from external influences.
- Incorrect operation of the equipment.

Frequently Asked Questions

Question: What kinds of Vehicles can I raise on my 9APF Lift?

Answer: Cars, trucks, SUVs, or similar; up to 9,000 lbs. (4,082 kg) each.

Q: What kinds of Vehicles can I raise on my 12APF Lift?

A: Cars, trucks, SUVs, or similar; up to 12,000 lbs. (5,443 kg) each.

Q: How long will it take to raise or lower my Vehicle?

A: Anywhere from 30 to 45 seconds, depending on how high you raise it.

Q: Does the Lift have to be anchored in place?

A: Yes. Two-Post Lifts **must** be anchored. Your Lift is delivered with high-quality Anchor Bolts; use **only** the Anchor Bolts delivered with your Lift.

Q: How thick does my concrete have to be?

A: For **9APF**: 4.25 in. thick, 3,000 PSI, cured for a minimum of 28 days. For **12APF**: 6.5 in. (165 mm) thick, 3,000 PSI, cured for a minimum of 28 days. Do not install the Lift on cracked or defective concrete. **Do not install on asphalt or any surface other than concrete.**

Q: Can I install my Lift outside?

A: No. All BendPak 2 Post Lifts are approved for indoor installation and use only. **Outdoor installation is prohibited.**

Q: How many Safety Lock positions does my Lift have?

A: The **9APF** has 14 Safety Lock Positions spaced roughly 3.625 in. (92 mm) apart. The **12APF** has 15 Safety Lock Positions spaced about 3.898 in. (99 mm) apart.

Q: Does the Lift have a Front and Rear?

A: Yes and no. It is possible to drive onto a Two-Post Lift from either opening, there is technically no Front or Rear. However, most garages or service bays have an Approach side and a Wall side, so in that case, the Wall side is the Front, and the Approach side is the Rear.

Q: How long can I leave a Vehicle raised up on my Lift?

A: Indefinitely, if you leave the Lift *engaged* on its Safety Locks. Once the Lift is engaged on its Safety Locks, gravity holds it in position. **Only leave your Lift either on the ground (fully lowered) or engaged on its Safety Locks.**

Q: How do I know where to put the Adapters when I want to raise a Vehicle?

A: The Vehicle needs to be balanced on the Lift, so you must position the Adapters (sometimes called Pads) so that they contact the manufacturer's recommended Lifting Points. **If you do not know where the manufacturer's recommended Lifting Points are on a Vehicle, you must find out before you raise it.** **ALI provides guides:** *Vehicle Lifting Points for Frame Engaging Lifts* provides the Lifting Points for hundreds of Vehicles. *Lifting It Right* includes information about how to raise Vehicles correctly and safely.

Components

9APF shown with optional equipment.

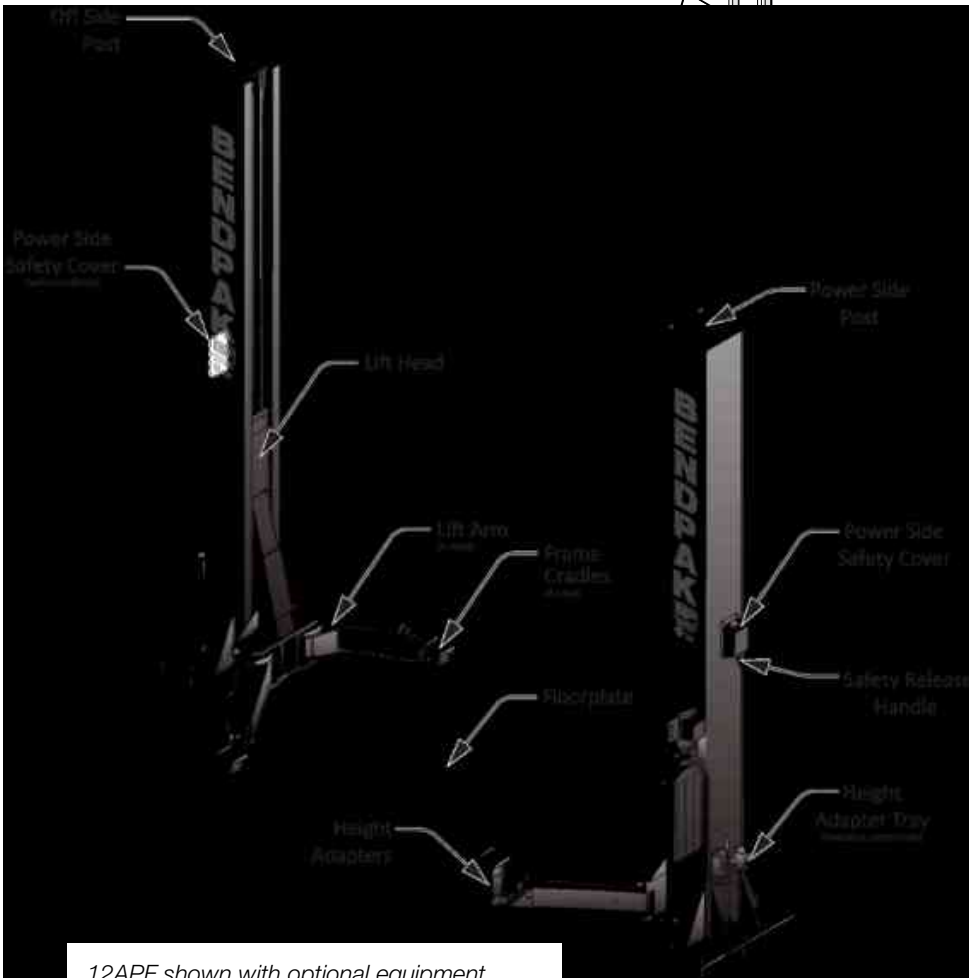
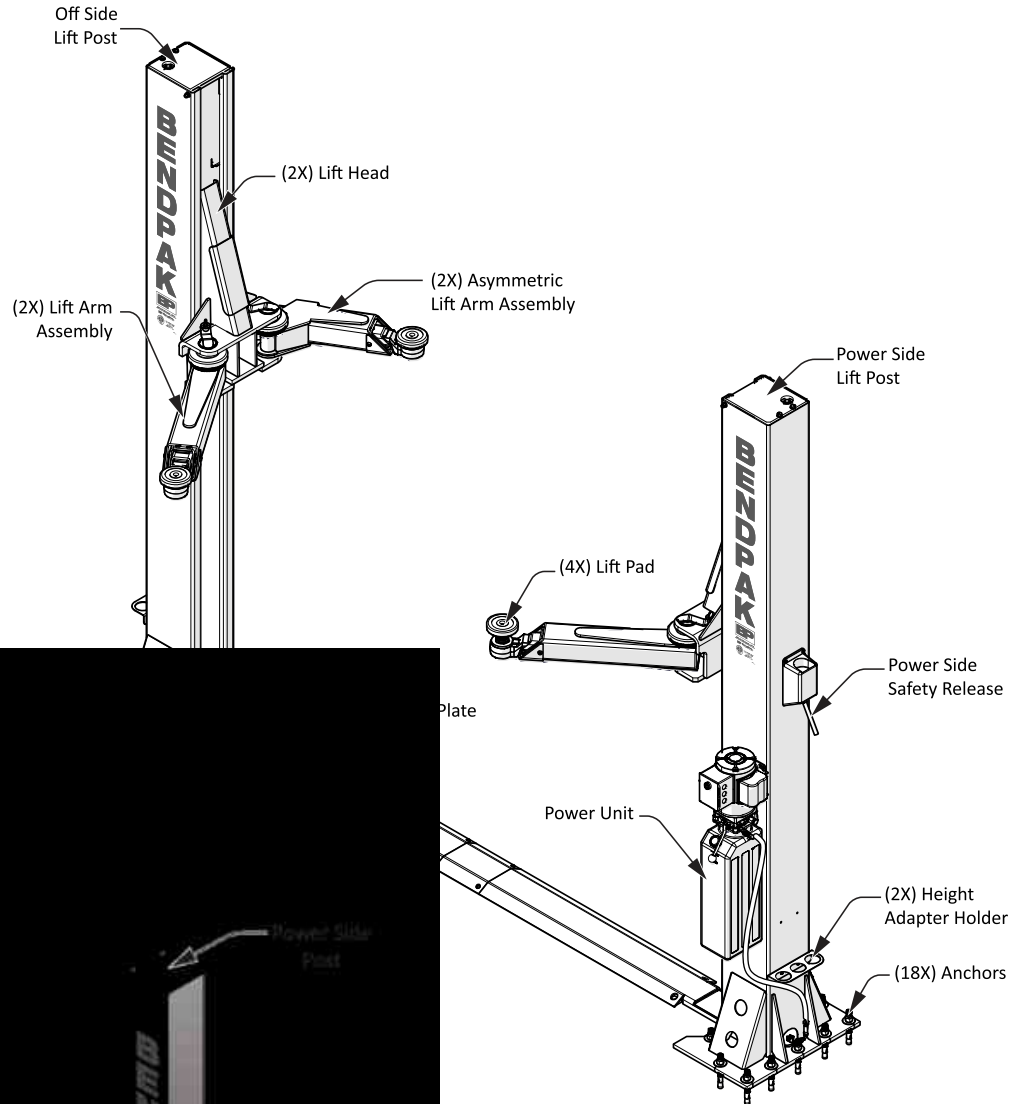

12APF shown with optional equipment.

9APF/12APF Lift Components include:

- **Power Side Post** — The power side post holds the power unit, the safety lock release handle, and the lowering handle (as a part of the power unit).
- **Off Side Post** — The lift post without the power unit mounting bracket.
- **Power Unit** — Is an electric hydraulic pump that provides hydraulic fluid under pressure to the lift cylinders and connects to an appropriate electrical power source. Controls include the up button, and the lowering valve handle. Hydraulic fluid is held in a reservoir below the pump motor.
- **Safety Lock Release Handle** — Located on the power post above the power unit, it disengages the safety locks so you can lower the Lift.
- **Safety Covers** — Cover the safety lock mechanism on the posts.
- **Floor Plate** — A formed steel plate covering the hydraulic hoses, equalizing cables, and safety cable being routed to each lift post.
- **Lift Heads** — Sometimes called carriages. Lift heads move up and down in the posts. They are connected to the lift arms, so that when the lift heads move up, the lift arms also move up, thus raising any vehicle on the lift arms.
- **Lift Arms** — Triple telescoping steel arms that attach to the lift heads. Lift pads and adapters attach at the end of each lift arm.
- **Lift Pads/Adapters** — Pads that contact the lifting points on the underside of the vehicles you raise. Four round adjustable Lift Pads are included with the 9APF lift, whereas 4 Frame Cradle Pads are included with the 12APF . Optional pads and adapters are available separately and include height adapters and frame cradle pads, which are well-suited for raising and holding trucks and SUVs (body-on-frame style vehicles).
- **Height Adapter Holders** — Attach to the lift posts, used to hold the adapters when not in use.
- **Safety Locks** — Mechanically hold the lift heads up when engaged. Multiple safety lock heights let you select the best height for the service task. Once engaged on its safety locks, the lift heads stay up, even if the lift loses power. Only leave your lift fully lowered or engaged on safety locks.

Safety locks are hidden between the lift head and the lift post, but you can hear them engage as the lift rises. Refer to [About Safety Locks](#) for more information.

9APF Specifications

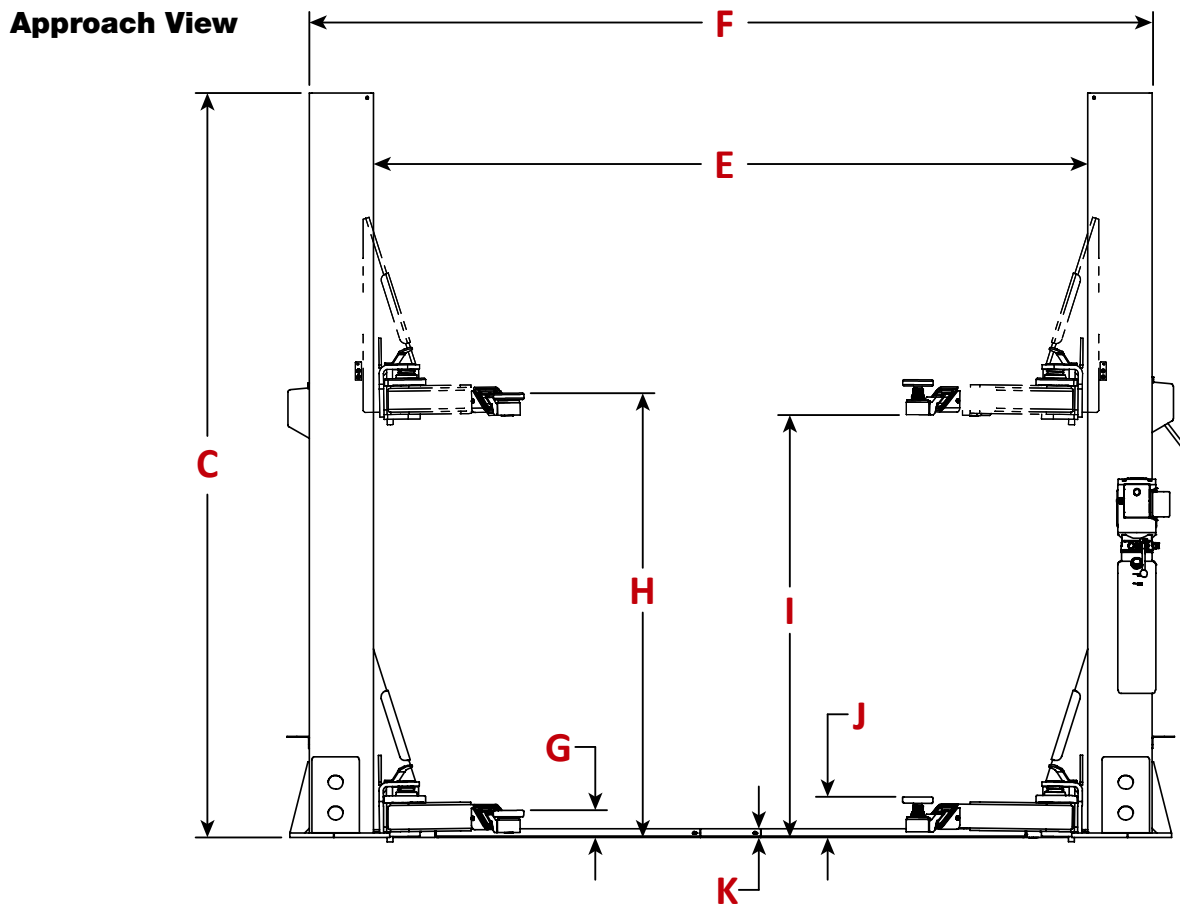
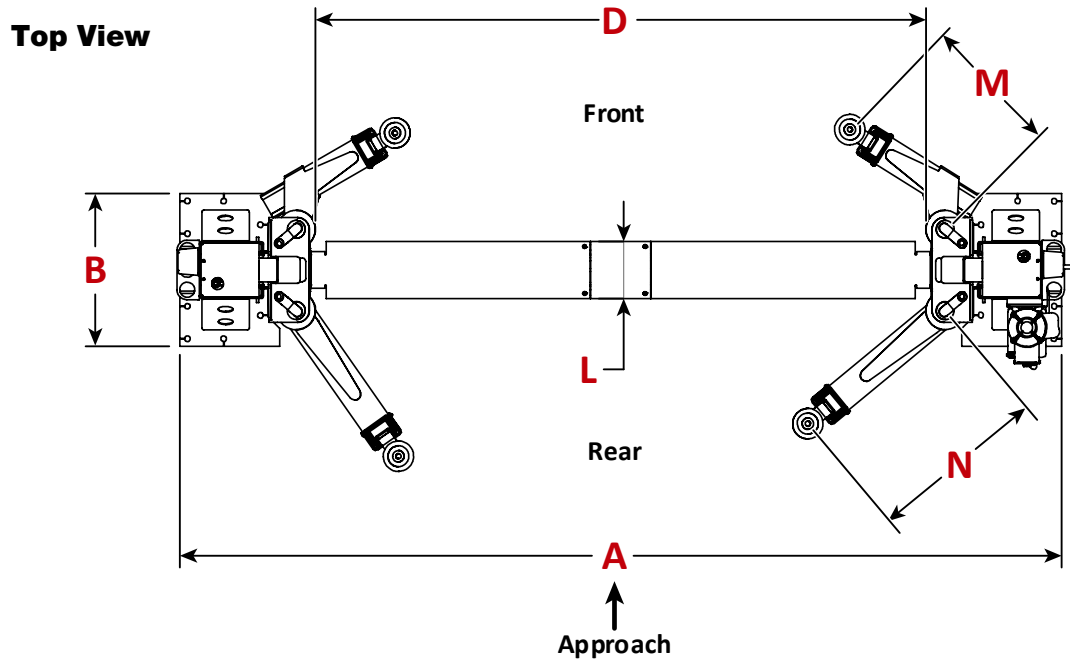

9APF Specifications

Specification	Value
Lifting Capacity	9,000 lbs. (4,082 kg)
Maximum Capacity – Front Axle	4,500 lbs. (2,041 kg)
Maximum Capacity – Rear Axle	4,500 lbs. (2,041 kg)
Maximum Capacity per Lift Arm	2,250 lbs. (1,021 kg)
A – Width Overall	136 or 146 in. (3,453 or 3,707 mm)
B – Base Plate Width	25.25 in. (642 mm)
C – Post Height	123 in. (3,128 mm)
D – Drive-Thru	91 or 101 in. (2,311 or 2,565 mm)
E – Inside Posts	108.25 or 118.25 in (2,749 or 3,003 mm)
F – Outside Posts	129.5 or 139.5 in. (3,289 or 3543 mm)
G – Minimum Height w/Pad	4.5 in. (114 mm)
H – Maximum Lifting Height ¹	73.5 in. (1867 mm)
I – Maximum Rise ²	70 in. (1,775 mm)
J – Maximum Pad Adjustment	2.25 in. (55 mm)
K – Floor Plate Height	1.4 in. (36 mm)
L – Floor Plate Width	9.5 in. (240 mm)
M – Asymmetric Arm Reach (min. – max.) ³	22.25 in. to 47.5 in. (562 mm to 1,205 mm)
N – Symmetric Arm Reach (min. – max.) ⁴	29.5 in. to 57 in. (747 mm to 1,446 mm)
Safety Lock Positions	14 Positions spaced every 3.62 in. (92 mm)
Time to Full Rise	≈68 Seconds
Operating Hydraulic Pressure under Max. Load	2,170 psi
Hydraulic Fluid Required	3.6 gallons (13.6 Liters)
Standard Motor ⁵	208-240 VAC, 50/60 Hz, 1 Phase, Approx. 11 Amps
Operating Temperature	41° to 104°F (5° to 40°C)
Sound Pressure	81dB peak level
Sound Pressure Measurement Operating Conditions	73° F (23°C), 67% Relative Humidity, 29.91 in. Hg. Air Pressure, Wind 2 mph 60 dB Background Noise Level
Height and Distance of dB meter microphone	3 ft. (914 mm) High, 3 ft. (914 mm) Distance
Max. Noise Level measurement location	3 ft (914 mm) Distance & 0° to Power Unit
Noise Level Standard for measurement	IEC651 type 2, ANSI S1.4 type 2Complies with EN1493:2022
Operating Mode	No load
Declared Noise Emission Value	Single Number determined directly from measurements <i>NO uncertainty</i> included.
Noise Test Operating Conditions	23°C / Air Pressure 29.91 in. Hg. / Wind 2 mph / Humidity 67% / Air Quality Index 30

¹ *Max. Lifting Height w/Pad* is the max. height while not engaged on a Safety Lock and without adjustment or adapter(s).

² *Maximum Rise* is the maximum lifting height not engaged on the Safety Lock.

³ *Asymmetric Arm Reach* is range of reach from least to greatest.

⁴ *Symmetric Arm Reach* is range of reach from least to greatest.

⁵ *Special voltages available upon request.*

Specifications subject to change without notice. Dimensions rounded to the nearest 1/4 in. (6 mm).

12APF Specifications

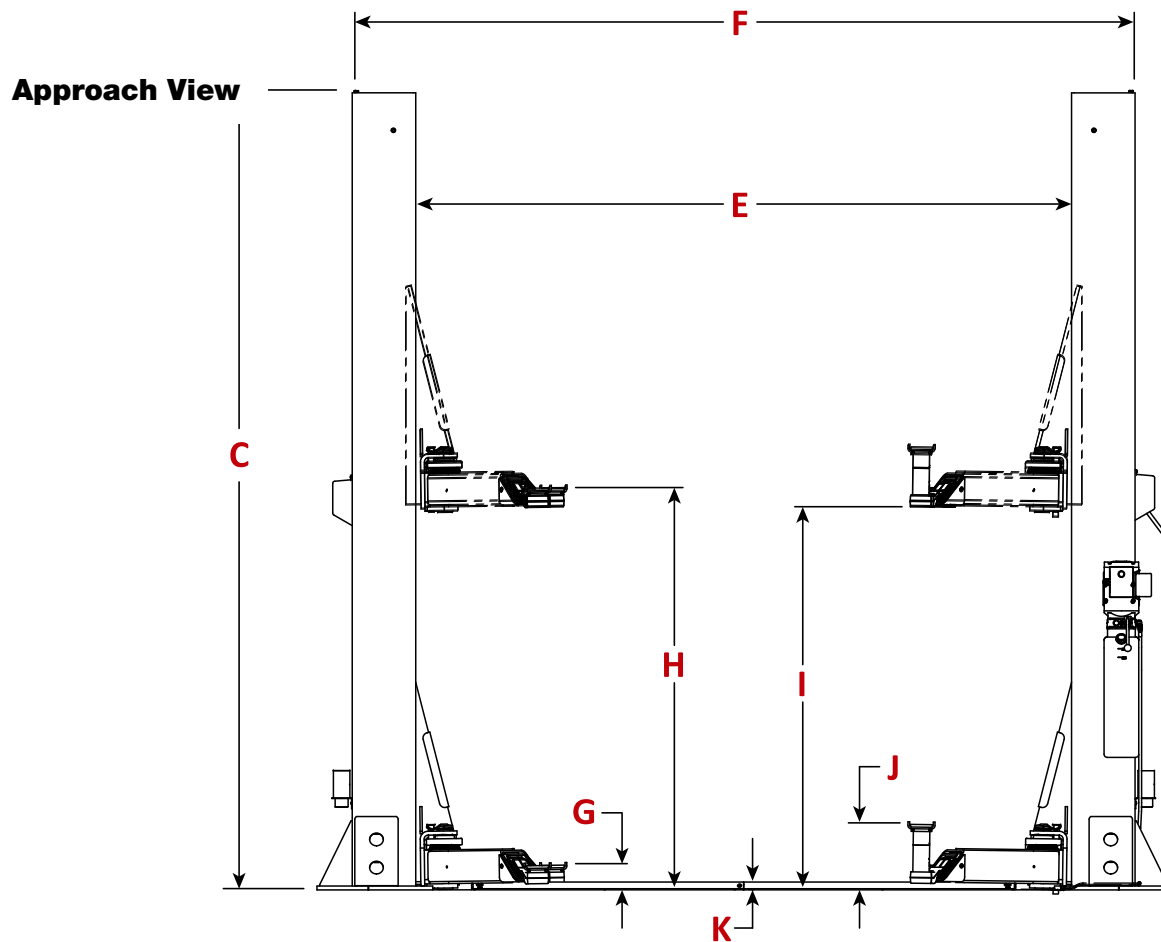
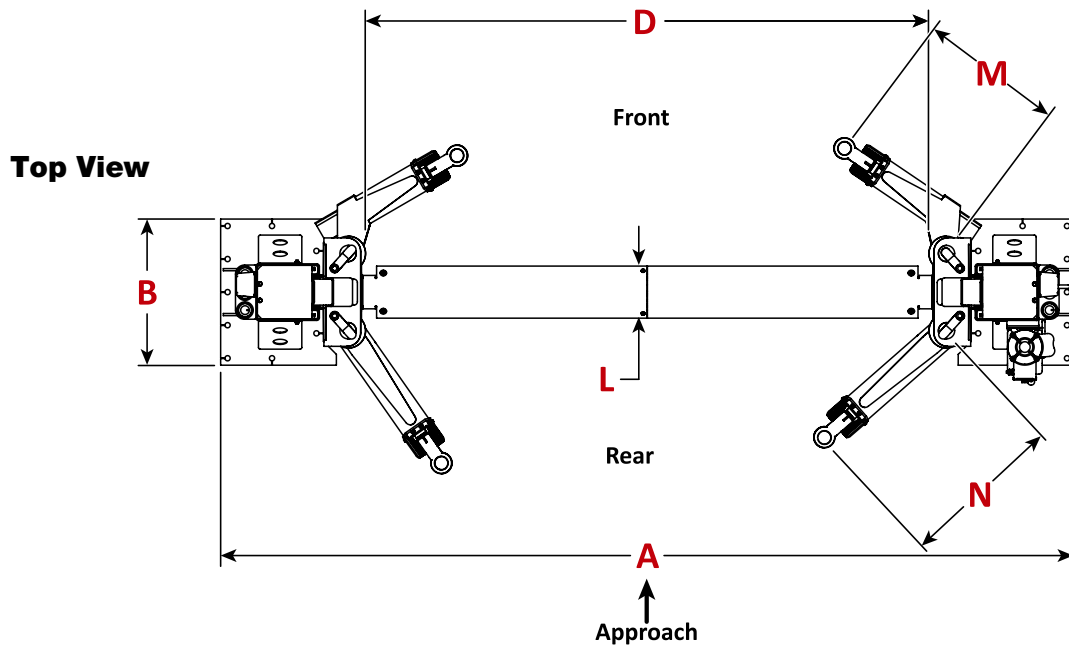

12APF Specifications

Specification	Value
Lifting Capacity	12,000 lbs. (5,443 kg)
Maximum Capacity – Front Axle	6,000 lbs. (2,722 kg)
Maximum Capacity – Rear Axle	6,000 lbs. (2,722 kg)
Maximum Capacity per Lift Arm	3,000 lbs. (1,361 kg)
A – Width Overall	155 in. (3,937 mm)
B – Base Plate Width	26.5 in. (674 mm)
C – Post Height	144.75 in. (3,676 mm)
D – Drive-Thru	102.25 in. (2,599 mm)
E – Inside Posts	119.125 in. (3,026 mm)
F – Outside Posts	142.25 in. (3,612 mm)
G – Minimum Height w/Frame Cradle	4.5 in. (114 mm)
H – Maximum Lifting Height w/Frame Cradle ¹	73.5 in. (1,865 mm)
I – Maximum Rise ²	70 in. (1,780 mm)
J – Frame Cradle Height with Med. and Long Adapters	11.75 in. (300 mm)
K – Floor Plate Height	1.5 in. (36 mm)
L – Floor Plate Width	9.5 in. (240 mm)
M – Asymmetric Arm Reach (min. – max.) ³	26 in. to 55.25 in. (660 mm to 1,404 mm)
N – Symmetric Arm Reach (min. – max.) ⁴	29.5 in. to 60 in. (745 mm to 1,524.5 mm)
Safety Lock Positions	15 Positions spaced every 4 in. (99 mm)
Time to Full Rise	≈68 Seconds
Operating Hydraulic Pressure under Max. Load	2,170 psi (14.96 MPa)
Hydraulic Fluid Required	3.6 gallons (13.6 Liters)
Standard Motor ⁵	208-240 VAC, 50/60 Hz, 1 Phase, Approx. 11 Amps
Operating Temperature	41° to 104°F (5° to 40°C)
Sound Pressure	81dB peak level
Sound Pressure Measurement Operating Conditions	73° F (23°C), 67% Relative Humidity, 29.91 in. Hg. Air Pressure, Wind 2 mph 60 dB Background Noise Level
Height and Distance of dB meter microphone	3 ft. (914 mm) High, 3 ft. (914 mm) Distance
Max. Noise Level measurement location	3 ft (914 mm) Distance & 0° to Power Unit
Noise Level Standard for measurement	IEC651 type 2, ANSI S1.4 type 2Complies with EN1493:2022
Operating Mode	No load
Declared Noise Emission Value	Single Number determined directly from measurements <i>NO uncertainty</i> included.
Noise Test Operating Conditions	23°C / Air Pressure 29.91 in. Hg. / Wind 2 mph / Humidity 67% / Air Quality Index 30

¹ *Max. Lifting Height w/Pad* is the max. height while not engaged on a Safety Lock and without adjustment or adapter(s).

² *Maximum Rise* is the maximum lifting height not engaged on the Safety Lock.

³ *Asymmetric Arm Reach* is range of reach from least to greatest.

⁴ *Symmetric Arm Reach* is range of reach from least to greatest.

⁵ *Special voltages available upon request.*

Specifications subject to change without notice. Dimensions rounded to the nearest 1/4 in. (6 mm).

Installation Checklist

Following are the steps required to install a 9APF or 12APF Two-Post Lift; install in this order.

- 1. Review the safety rules and information in this Manual.
- 2. Plan for electrical work.
- 3. Make sure the necessary tools are available.
- 4. Review the Installation Procedure thoroughly, start to finish, prior to beginning any work.
- 5. Review the clearances around and above the Lift.
- 6. Select the installation location.
- 7. Create chalk line guides for the Lift Posts.
- 8. Move the equalizing cables into position within each Lift Post. Attach the cable button end to the Lift Head Lock Plate.
- 9. Stand up the Lift Posts in the chalk Lines.
- 10. Install the Equalizing Cables, attach each threaded cable end on the opposite Post's Lift Head.
- 11. Install the double threaded rod at the top of both Lift Posts.
- 12. Anchor the Posts.
- 13. Install the Safety Lock Cable.
- 14. Review About Hydraulic Contamination.
- 15. Review About Thread Sealant.
- 16. Install the Hydraulic Fittings into the Cylinders.
- 17. Install the Power Unit, but do not connect to electrical power.
- 18. Install and Connect the Hydraulic Hoses.
- 19. Install Cylinder Chain and Roller (**9APF Only**).
- 20. Review About Arm Restraint Gears.
- 21. Install the Lift Arms. If optional Footguard rails were purchased, mount those on installed Lift Arms.
- 22. Contact the Electrician.
- 23. Install the Power Disconnect Switch (**Electrician required**).
- 24. Install the Thermal Disconnect Switch (if required by local electrical code).
- 25. Connect the Power Unit (**Electrician required**).
- 26. Install the Safety Covers.
- 27. Perform final Leveling.
- 28. Lubricate the Lift.
- 29. Perform an Operational Test.
- 30. Review the final Checklist.
- 31. Leave the Manual with the Owner/Operator.



Installation

The installation process requires multiple steps. Perform them in the order listed.

Read the entire Installation section start-to-finish before beginning. Doing so will provide a better understanding of the process.

⚠ WARNING **Only use the factory-supplied parts that came with your Lift.** If you use parts from a different source, you void your warranty and compromise the safety of everyone who installs or uses the Lift. If parts are missing, visit bendpak.com/support or call **(800) 253-2363**, then follow the prompts.

Being Safe

While installing this equipment, safety for all depends on proper training and thoughtful operation.

⚠ WARNING Do not install this equipment unless you have automotive Lift installation training. Always use proper lifting tools such as a Forklift or Shop Crane to move heavy components. Do not install this equipment without reading and understanding this manual and the safety labels on the unit.

⚠ WARNING Many of the Lift components are heavy and awkward to work with. Installation should be accomplished by competent personnel ensuring all heavy components are properly rigged and balanced for lifting. Installation personnel should have knowledge, training, and experience in lifting, rigging, and securing heavy objects.

Only fully trained personnel should be involved in installing this equipment. Always pay attention. Use appropriate tools and lifting equipment. Stay clear of moving parts.

BendPak recommends referring to the current version of the ANSI/ALI ALIS Standard *Safety Requirements for Installation and Service* for more information about safely installing, using, and servicing the Lift.

⚠ WARNING You **must** always wear OSHA-APPROVED (publication 3151) personal protective equipment when installing, using, maintaining, or repairing the Lift: leather gloves, steel-toed work boots, eye protection, back belts, and hearing protection are **mandatory**.

Required Tools

You may need some or all the following tools:

- Rotary hammer drill or similar
- 3/4 in. (19 mm) carbide bit (conforming to ANSI B212.15)
- 11/32 in. (8-9 mm) carbide bit (pilot hole)
- Hammer, crow bar, and two sawhorses
- 4 ft. (1,219 mm) level and two 12 ft. (3,657 mm) ladders
- Open-end wrench set, SAE, and metric
- Socket and ratchet set, SAE, and metric
- Red and White Lithium Grease
- Hex key wrench set
- Medium crescent wrench, torque wrench, and pipe wrench
- Chalk line
- Medium-sized flat screwdriver and needle-nose pliers
- Tape measure: 25 ft. min. (7,620 mm)
- Forklift, Shop Crane, or heavy-duty rolling dolly

Planning for Electrical Work

A licensed Electrician is required to connect the Lift to electrical power.

Notify your Electrician in advance so that they arrive prepared with appropriate wiring or cable with a plug for connecting to the power source, a Power Disconnect Switch, and a Thermal Disconnect (if required by local electrical code).

NOTICE Wiring and disconnects must be provided by the Electrician; they are not supplied with the Lift.

⚠ DANGER A licensed Electrician must install all wiring. Verify electrical work conforms to all applicable local and federal codes, rules, and regulations, such as state and federal OSHA regulations and electrical codes.

The Electrician is required to:

- **Connect the Power Unit to an electrical power source.** The Power Unit is delivered with a pigtail for wiring to a power source. Have the Electrician remove the pigtail and wire from inside the electrical box on the Power Unit to a power cord and plug or have them wire it directly into the electrical system at the Lift location.

Note: Installing the Power Unit and connecting the Power Unit to the power source are *separate* procedures and are completed at different times in the installation process. You do not need an Electrician to install the Power Unit on the Power Post, but an Electrician is **required** to connect the Power Unit to the power source.

- **Install a Power Disconnect Switch.** Ensures you can quickly and completely interrupt electrical power to the Lift in the event of an electrical circuit fault, emergency, or when equipment is undergoing service or maintenance. Put it within sight and reach of the Lift operator.
- **Installing a Thermal Disconnect Switch.** The Power Unit supplied with this Lift **does not** include thermal overload protection. Under NEC 430, UL 201, and CSA C22.2 No. 68 intermittent duty motors are **not** required to include thermal protection. Local electrical codes may vary, and other requirements may exist that the installing electrician will address, as required.

⚠ DANGER If local Electrical codes require the installation of a Thermal Disconnect, the disconnecting device and the installation **must** be provided and installed by a licensed Electrician in accordance with local electrical codes. Do not perform **any** maintenance or installation on the Lift without first verifying that main electrical power has been disconnected from the Lift and **cannot** be re-energized until all procedures are complete.

Electrical Information

Important electrical information:

- Improper electrical installation can damage the Power Unit motor, which is not covered by the warranty.
- The Lift uses electrical energy; if your organization has Lockout/Tagout policies, make sure to implement them after connecting to a power source.
- Use a separate circuit breaker for each Power Unit.
- Protect each circuit with a time delay fuse or circuit breaker:
 - For a 208 to 230 VAC, single phase circuit, use a 25 amp fuse.

Checking Clearances

For safety purposes, clear space *around and above* the Lift is **required**. Drawings are not to scale.

9APF Lift Clearances

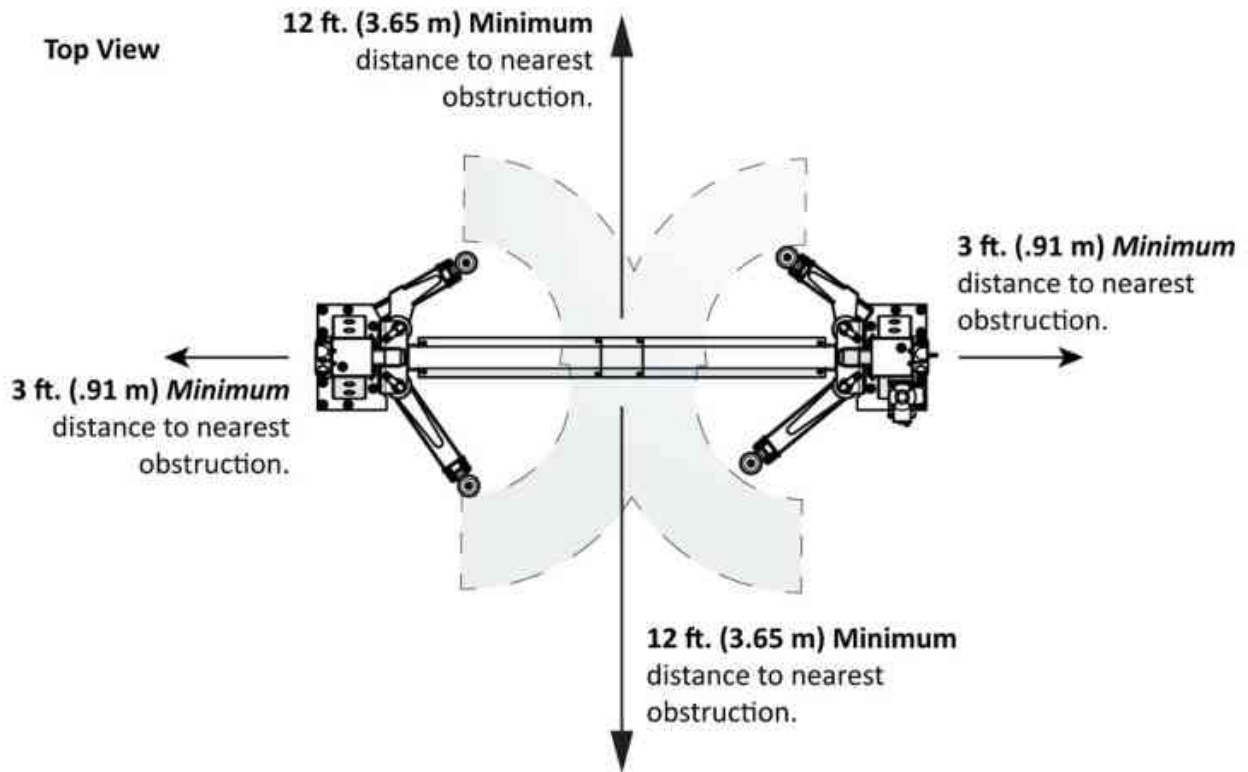

Note! Additional distance is required for Vehicles to be driven onto and off of the Lift.

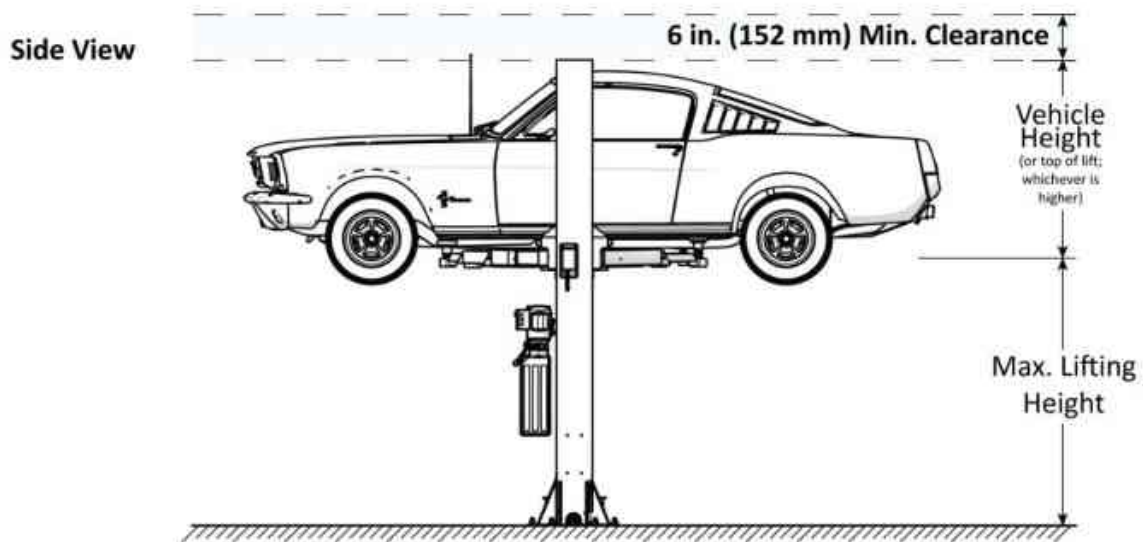

12APF Lift Clearances

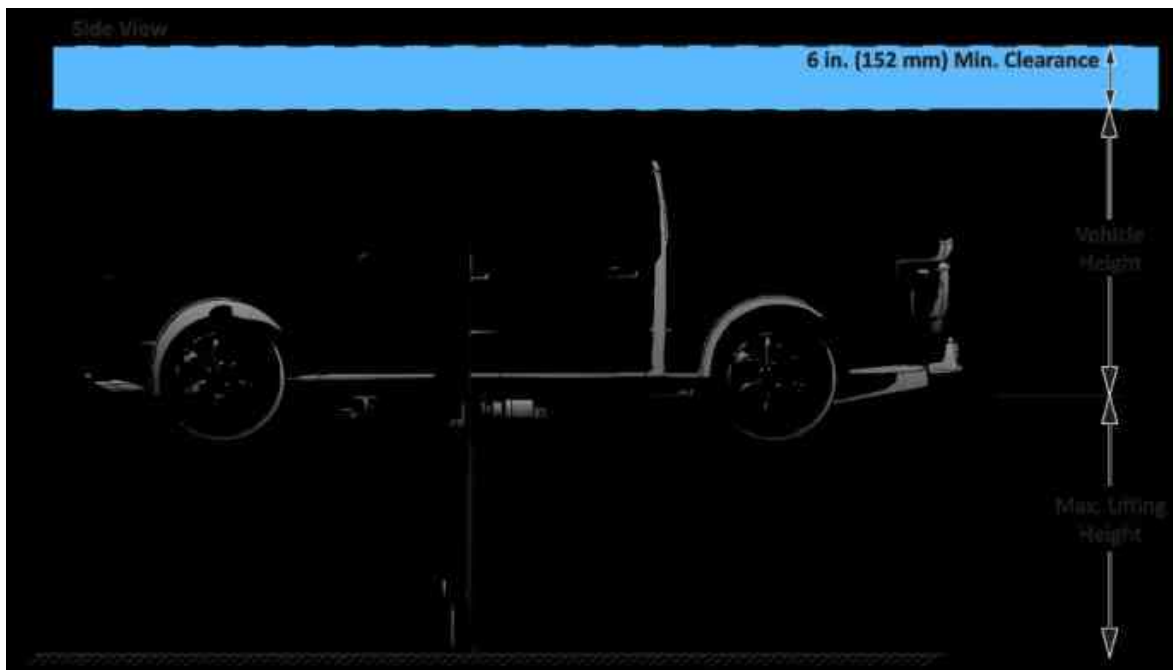
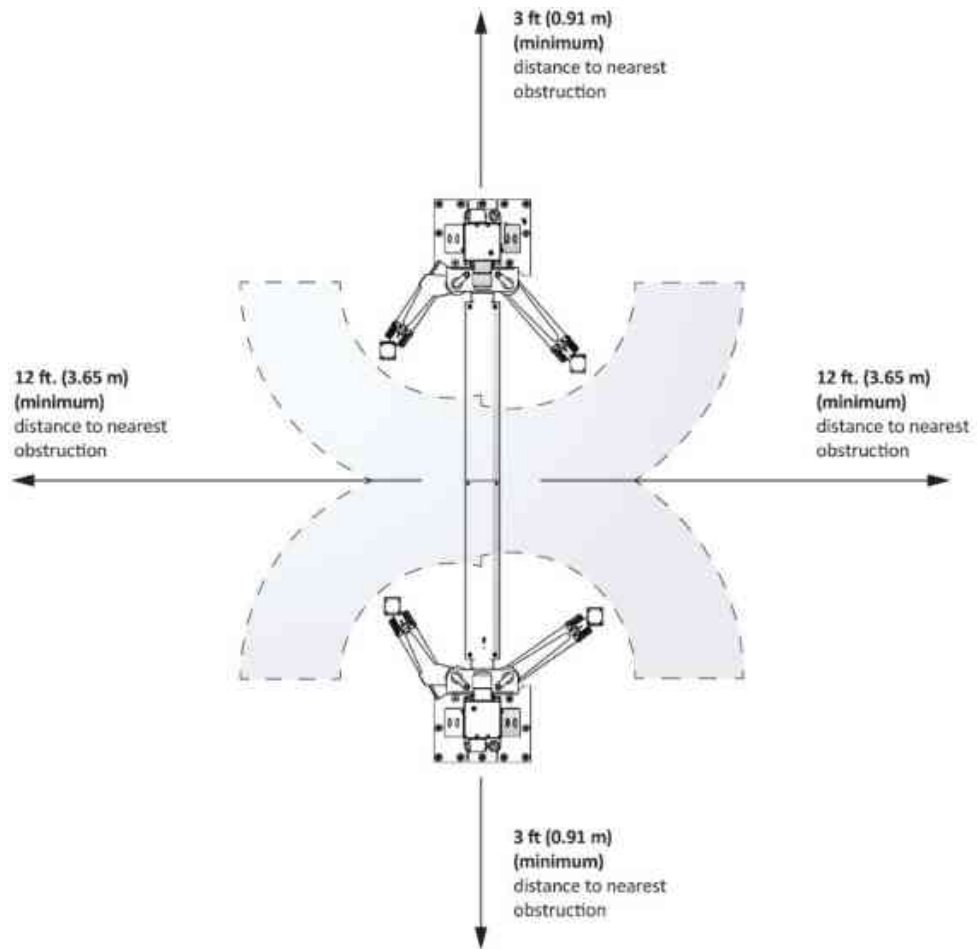

Choosing a Wide or Narrow Configuration **9APF Only**

The **9APF** may be installed in *either* a Wide or Narrow Configuration:

- **Wide Configuration.** The Posts are further apart, which means you can raise wider vehicles on the Lift. This is usually the best choice **if** your Lift location is wide enough to support it. When installing the Equalizing Cables, use the Button End at the *very end* of the cable.

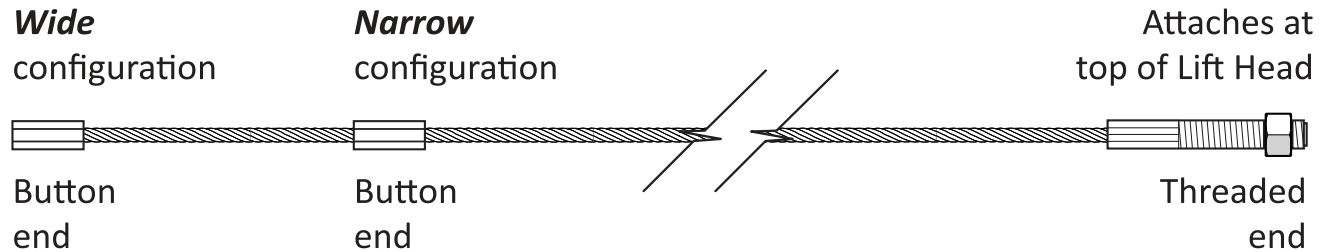

- **Narrow Configuration.** The Posts are closer together. This is usually the best choice for narrower garages, as it uses less width. When you are installing the Equalizing Cables, use the Button End **away** from the end of the cable.
- **Routing the Equalizing Cables.** The Equalizing Cables are delivered with two Button ends, one for the Wide Configuration and one for the Narrow Configuration.
- **Creating the Chalk Line Guides.** Use the **Width Overall** setting (found in [Specifications](#)) to create the Chalk Line Guides, to determine how far apart the Posts must be. There are two Width Overall settings, one for the Wide Configuration and one for the Narrow Configuration.
- Determine the Wide or Narrow Configuration of the Lift before continuing the installation process.

Lubricants and Hydraulic Fluid Required

The following hydraulic fluid and lubricants are required, but not supplied with the Lift.

- Any general-purpose ISO-32, ISO-46, or ISO-68 hydraulic oil
- White Lithium Multi-Purpose Lubricant
- Red Lithium Grease
- ALMASOL Wire Rope Lubricant or 90W Gear Oil

Selecting a Location

When selecting the location for your Lift, consider:

- **Architectural plans.** Consult the architectural plans for the desired location. Make sure there are no contradictions between what is planned and what the architectural drawings will allow.
- **Available space.** Make sure there is enough space for the Lift: front, back, sides, and **above**. Refer to **Specifications** for exact measurements.
- **Overhead Clearance.** Check for overhead obstructions such as building supports, heaters, electrical lines, low ceilings, hanging lights, and so on. Use the maximum lifting height of your Lift model plus the height of the tallest vehicle you plan on raising to determine how much height you will need at the Lift location.

Power. An appropriate electrical power source for the Lift's Power Unit is required.

 **DANGER** The Power Unit supplied with this Lift *does not* include thermal overload protection. Under NEC 430, UL 201, and CSA C22.2 No. 68 intermittent duty motors are not required to include thermal protection. Local electrical codes may vary, and other requirements may exist that the installing electrician will address, if required.

 **DANGER** If local Electrical codes require the installation of a Thermal Disconnect, the disconnecting device and the installation **must** be provided by a licensed Electrician in accordance with local electrical codes. Do not perform **any** maintenance or installation on the Lift without first verifying that main electrical power has been disconnected from the Lift and **cannot** be re-energized until all procedures are complete.

 **DANGER** Risk of explosion: The Power Unit has internal components that may spark and should not be exposed to flammable vapors. This device is not intrinsically safe. Internal Arcing may ignite combustible gases; the Power Unit must be mounted at least 18 in. above the ground.

 **DANGER** Never expose the Power Unit motor to rain or other damp environments. Damage to the motor caused by water is **not** covered by the warranty.

- **Outdoor installations.** Your Lift is approved for **indoor installation and use only**. *Outdoor installation is prohibited.*
- Do **not** install the Lift on any surface other than steel reinforced concrete conforming to the minimum compressive strength, aging, reinforcement, and thickness stated in these requirements.
- **Never** install the Lift over a concrete expansion joint.
- All Anchors **must** be a minimum of 6 in. (152 mm) away from any expansion seams, control joints or other inconsistencies in the concrete.
- **Never** install the Lift on hand-mixed concrete.
- Do **not** install the Lift on a secondary floor level or on any ground floor with a basement beneath without written authorization from the building Architect and prior approval of BendPak Inc.

 **WARNING** Installing your Lift on a surface with more than three degrees of slope could lead to injury or even death. Only install the Lift on a level floor (defined as no more than 3/8 of an inch difference over the installation area). If your floor is not level, consider making the floor level or using a different location.

- **Shimming.** If your concrete floor is not completely level, Shims may be used under the bases of the Posts, as needed, to level the Lift. To estimate your Shim requirements, use a transit level and targets to check for flatness. Use the provided shims, as necessary.

NOTICE Do not shim a Post more than ½ in. (13 mm) using the provided Shims and Anchor Bolts. A maximum shim of 2 in. (51 mm) is possible by ordering optional Shim Plates. Contact BendPak at **(800) 253-2363**, follow the prompts to order.

- **Concrete specifications.** Do not install the Lift within 6 in. (152 mm) of cracked or defective concrete. Make sure the concrete is at least 4.25 in. (108 mm) **[9APF]** or 6.25 in. (165 mm) **[12APF]** thick, 3,000 PSI, and cured for a minimum of 28 days.

CAUTION BendPak lifts are supplied with installation instructions and concrete anchors that meet the criteria set by the current version of the American National Standard “Automotive Lifts – Safety Requirements for Construction, Testing, and Validation,” ANSI/ALI ALCTV. You are responsible for any special regional structural and/or seismic anchoring requirements specified by any other agencies and/or codes such as the Uniform Building Code (UBC) and/or International Building Code (IBC).

Be sure to check your floor for the possibility of it being a **post-tension slab**. In this case, contact the building architect **before** drilling. Use of ground penetrating radar may be required to find the tensioned steel.

DANGER Cutting through a tensioned Cable can result in injury or death. Do not drill into a post-tension slab unless the building architect confirms the area is free of tensioned steel or you have located it using ground penetrating radar. **If colored sheath comes up during drilling, stop drilling immediately.**

- **Unloading the Lift components.** Unload the Lift components as close to the installation location as possible. The Lift includes a number of heavy components, so the closer you unload them to the installation location, the better off you will be.

WARNING Some Lift components are **very** heavy; if handled incorrectly, they can damage materials like tile, sandstone, and brick. Try to handle the Lift components just twice: once when delivered and once when moved into position. You must have a Forklift or Shop Crane to move some of the Lift components into position. **Use care when moving Lift components.**

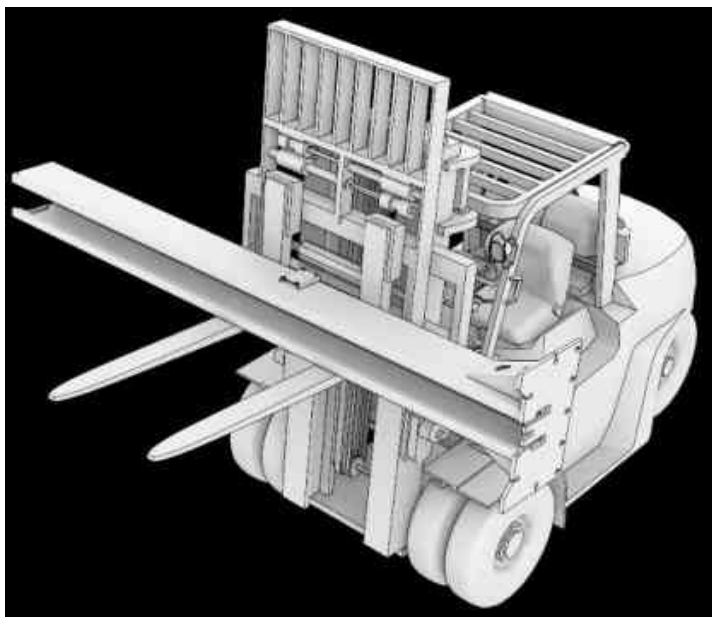

Creating Chalk Line Guides

Create Chalk Line Guides on the ground for the two Posts prior to moving them into position. Use the Width Overall value **for your Lift model** to determine where to place the Chalk Line Guides. The Width Overall value is the distance from the back of one base plate to the back of the other base plate. The **9APF** anchoring was created when the concrete recess was formed, see pg. 17.

Lift Model	Width Overall
9APF Narrow	136 in. (3,453 mm)
9APF Wide	146 in. (3,707 mm)
12APF	155 in. (3,937 mm)

The following drawing depicts the Chalk Line Guides for your Lift.

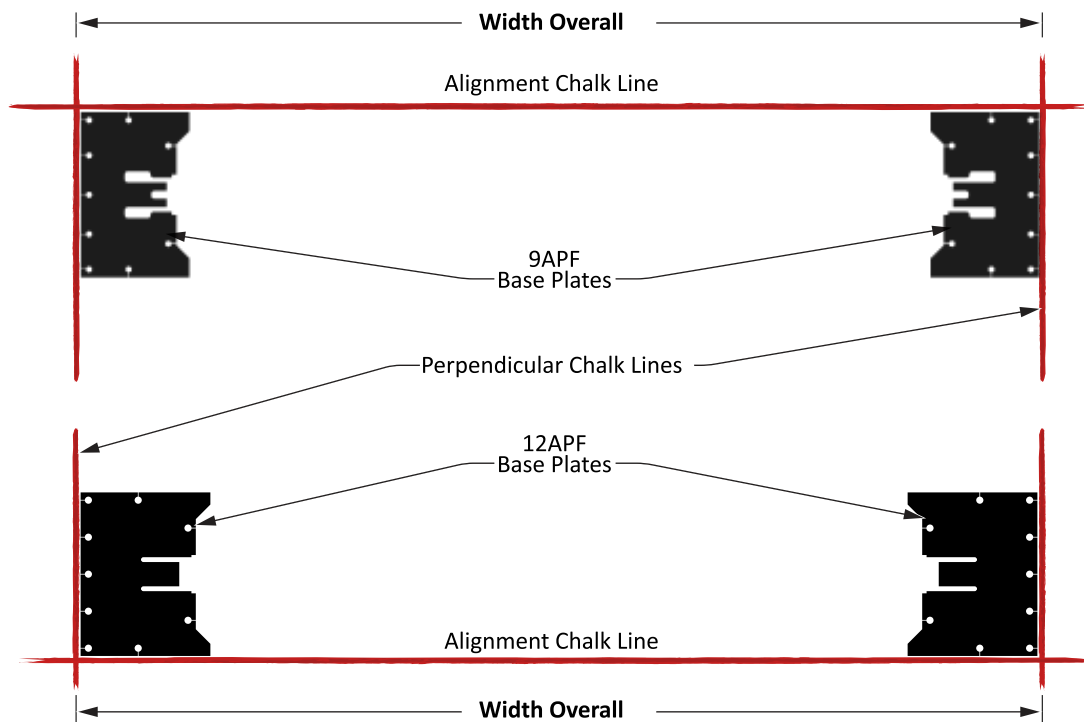

To add the Chalk Line Guides:

1. Determine the Lift's location.
2. Create an Alignment Chalk Line at the Front of the Lift. Refer to the Figure above.
Make the Alignment Chalk Line longer than the Width Overall setting for your Lift model.
For 9APF only, make sure to use the correct Width Overall setting for Narrow or Wide orientation.
3. Create two Perpendicular Chalk Lines at 90° angles to the Alignment Chalk Lines at the Width Overall distance for the Lift model you are installing.
The two Perpendicular Chalk Lines must be **X** distance from each other, where **X** is the Width Overall setting (9APF only narrow or wide) for your Lift model.
4. Put the Base Plates into the corners created by the Chalk Line Guides, as shown in the figure above.

Move the equalizing cables into position 9APF

It is far easier to put the Equalizing Cables Button Ends into position **before** standing up the Lift Posts. The Equalizing Cables keep the Lift Heads synchronized. If one Lift Head moves faster than the other Lift Head, or is otherwise mis-aligned, the Vehicle on the Lift could become unstable and fall.

The illustration below shows a 9APF Equalizing Cable.

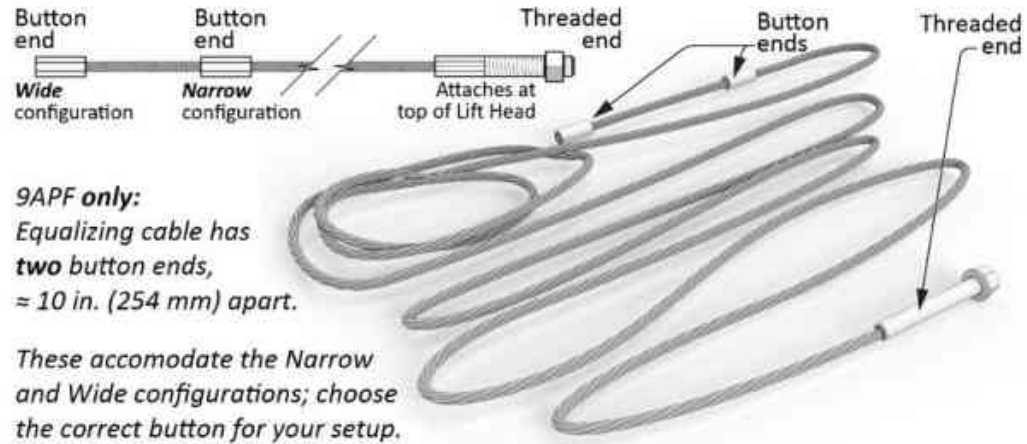

When Equalizing Cables are fully routed, they are mirror images of each other.

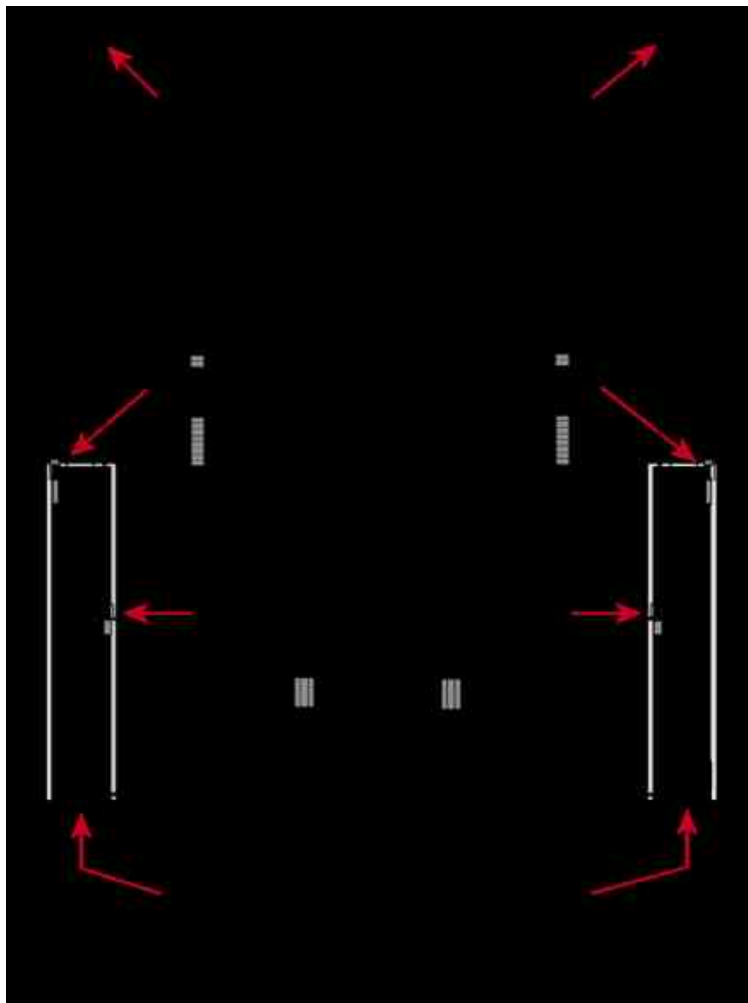

9APF:
(2X) Cable Assembly
5595856

⚠ CAUTION BendPak recommends wearing gloves while handling the Equalizing Cables.

To put the Equalizing Cables into position 9APF:

1. Using a forklift or equivalent, move the Posts near the Chalk Lines.
2. Place both Posts either flat on the ground or with their tops elevated on a sawhorse or similar; the insides of the Posts need to be accessible, facing up.
3. Slide the Lift Heads away from the bottoms of both Posts by at least 24 in. (610 mm), to provide room to work.

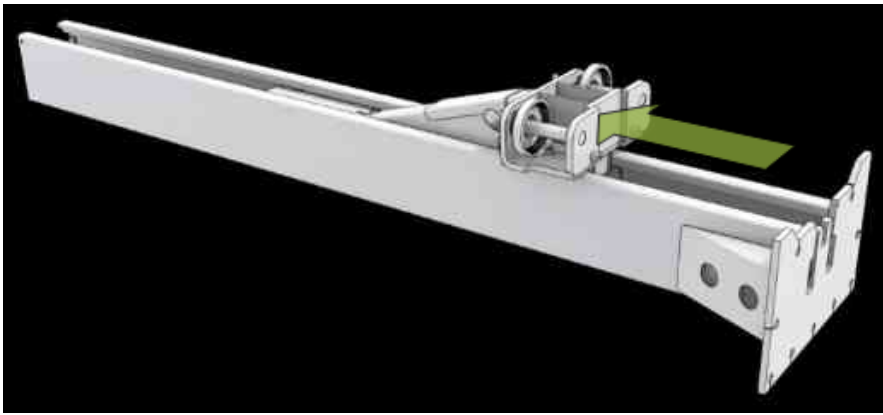

4. Remove the two Post Sheaves from the bottom of the Post. Keep the Cable Sheaves, Sheave Pins, and Hair Pins nearby; you will be re-installing them soon.

9APF:

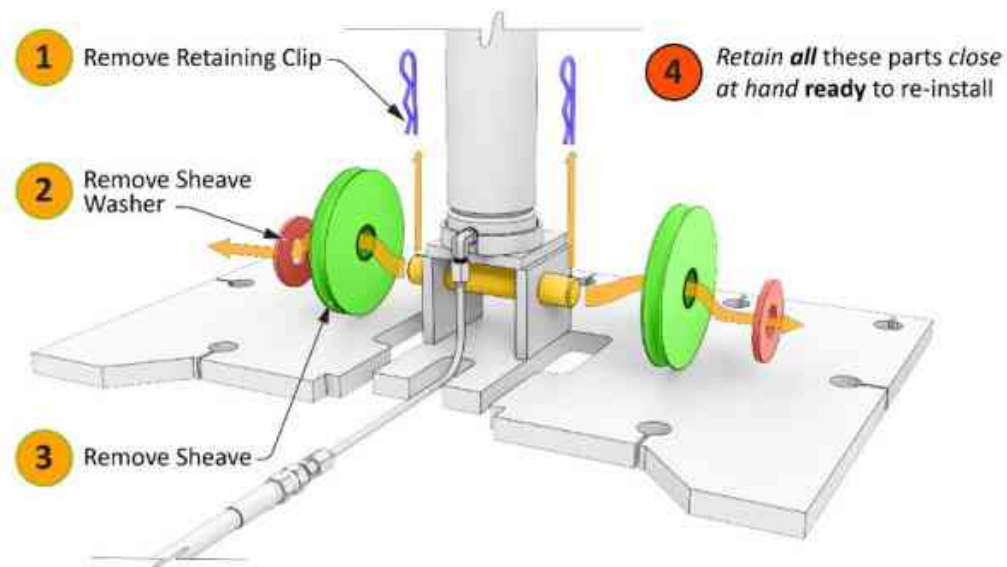

5. Locate the two Equalizing Cables.
For both lifts, the Equalizing Cables are the same length, so it does not matter which one you install first.
6. For **9APF** installations, determine the wide or narrow Button End you are going to use on the Cable.

7. For **9APF** installations, secure the Button end at the Carriage Lock Plate located inside each Lift Head.

Narrow configuration

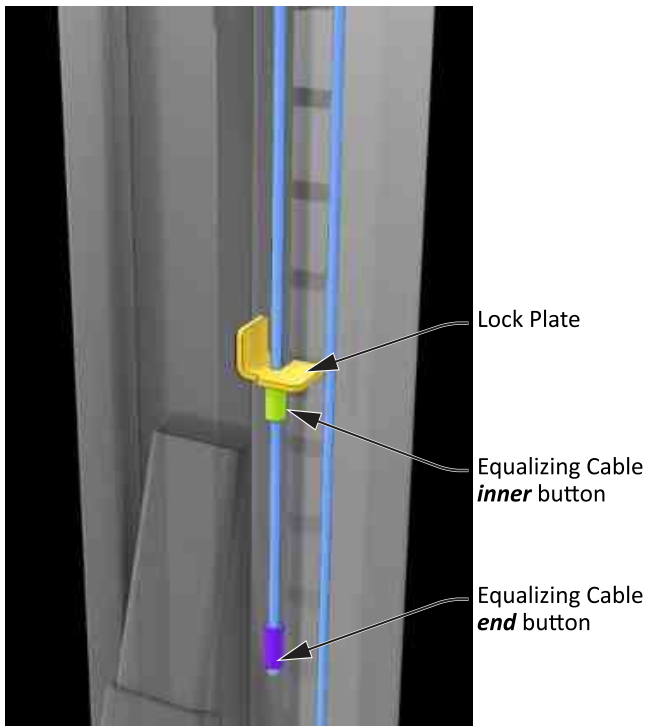

Wide configuration

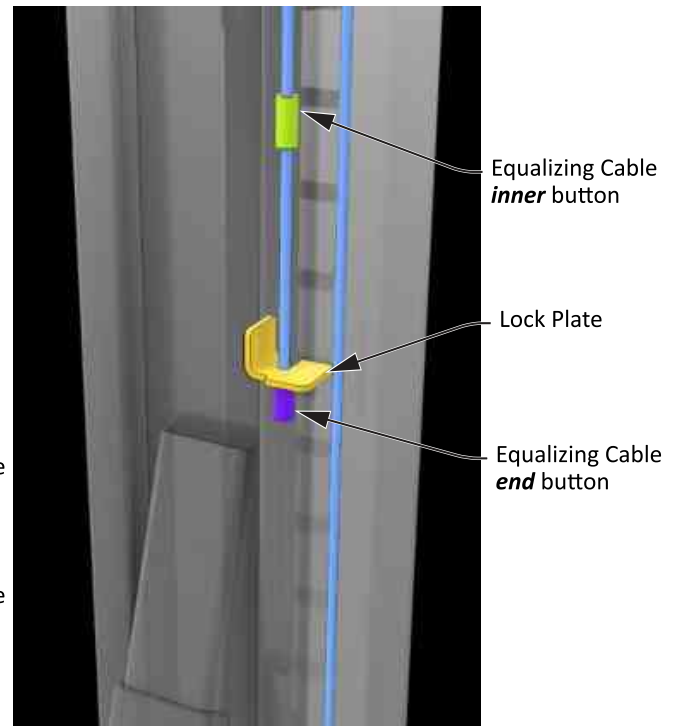

⚠ CAUTION Failure to secure the Button end may result in Lifting Chain failure or Lift malfunction.

8. Route the threaded end of the Cable *upwards* to the Top Plate Sheave.
9. Install the Top Plates on the top of the Posts and thread the cable around the Sheave. Refer to the next illustration.
10. Route the Cable down the Lift Post and around the Sheave at the bottom of the Post and out to the Opposite Post.
11. Route the Cable around the bottom Sheave and up to the Lift Head.
12. Insert the threaded end of the cable into the Cable Holder. Use the Washer and Nut to *loosely* secure the cable end to the Lift Head.
13. Retrieve the remaining Cable and repeat the procedure beginning on the opposite Post.

It can be difficult to get the Button End into the Slot, as it may be hard to reach the Lock Plate. You may want to use a metal rod or a long tool to push the Button End into the Slot.



If you are having problems getting the Button end into the Slot, you might want to try pushing the Button end past the Lock Plate. Then move the Equalizing Cable around to get the cable into the Slot. Once the cable is in the Slot, pull on the other end of the cable to slide the Button end into the Slot. Try to keep the cable taut until the Equalizing Cable is connected at the other end.

14. After the Cables are in place. Reinstall all Sheaves and pins (first apply new Red Lithium Grease to the pins) that were removed.
15. Verify the Top Plate at the top of each post is secured.
16. Carefully move both Lift Heads back down to the bottom of each Post.
17. On **both** Lift Posts, locate the two Double Threaded Rods (M10 x 275 mm rods, threaded on both ends), and for each Threaded Rod gather the two Nuts and two Washers also in the Parts Box, put them into place through the top of each Post (they go all the way through the top of the Post), and tighten them in place on both ends. Refer to the next illustration.

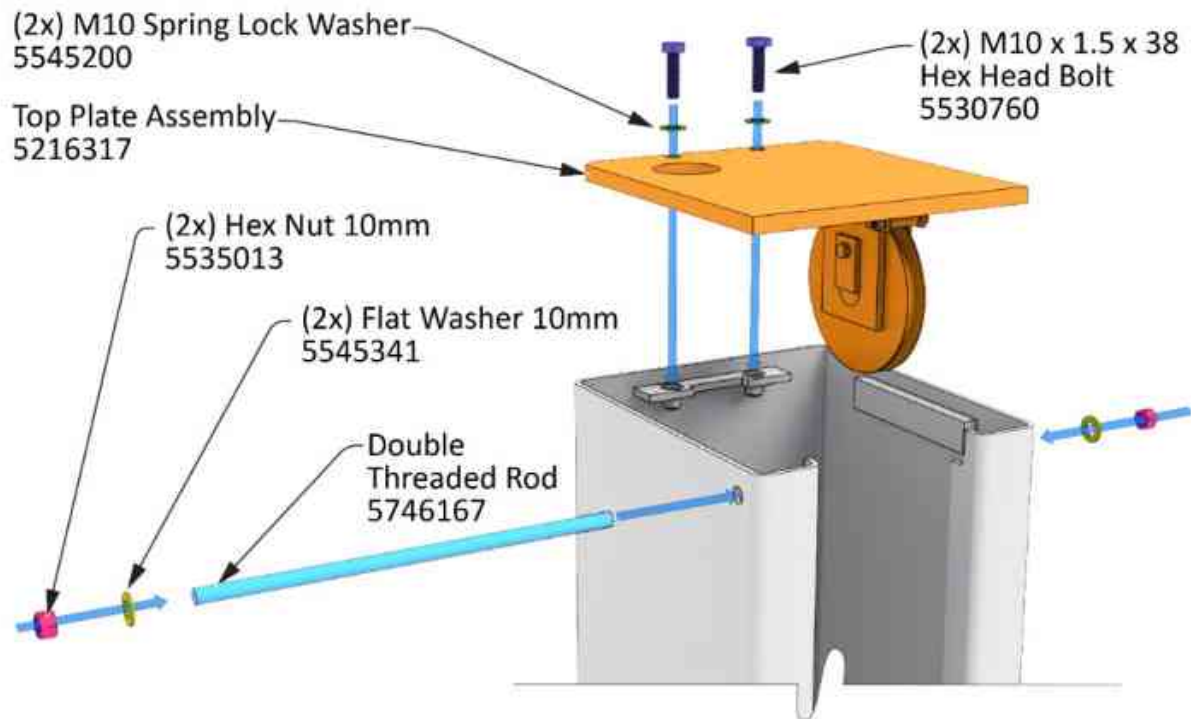

Move the equalizing cables into position **12APF**

It is much easier to put the Equalizing Cables into position **before** you stand up the 12APF Posts. The Equalizing Cables keep the Lift Heads synchronized. If one Lift Head lowers or raises faster than the other Lift Head; the Vehicle on the Lift would become unstable and could fall. When Equalizing Cables are fully routed, they are mirror images of each other.

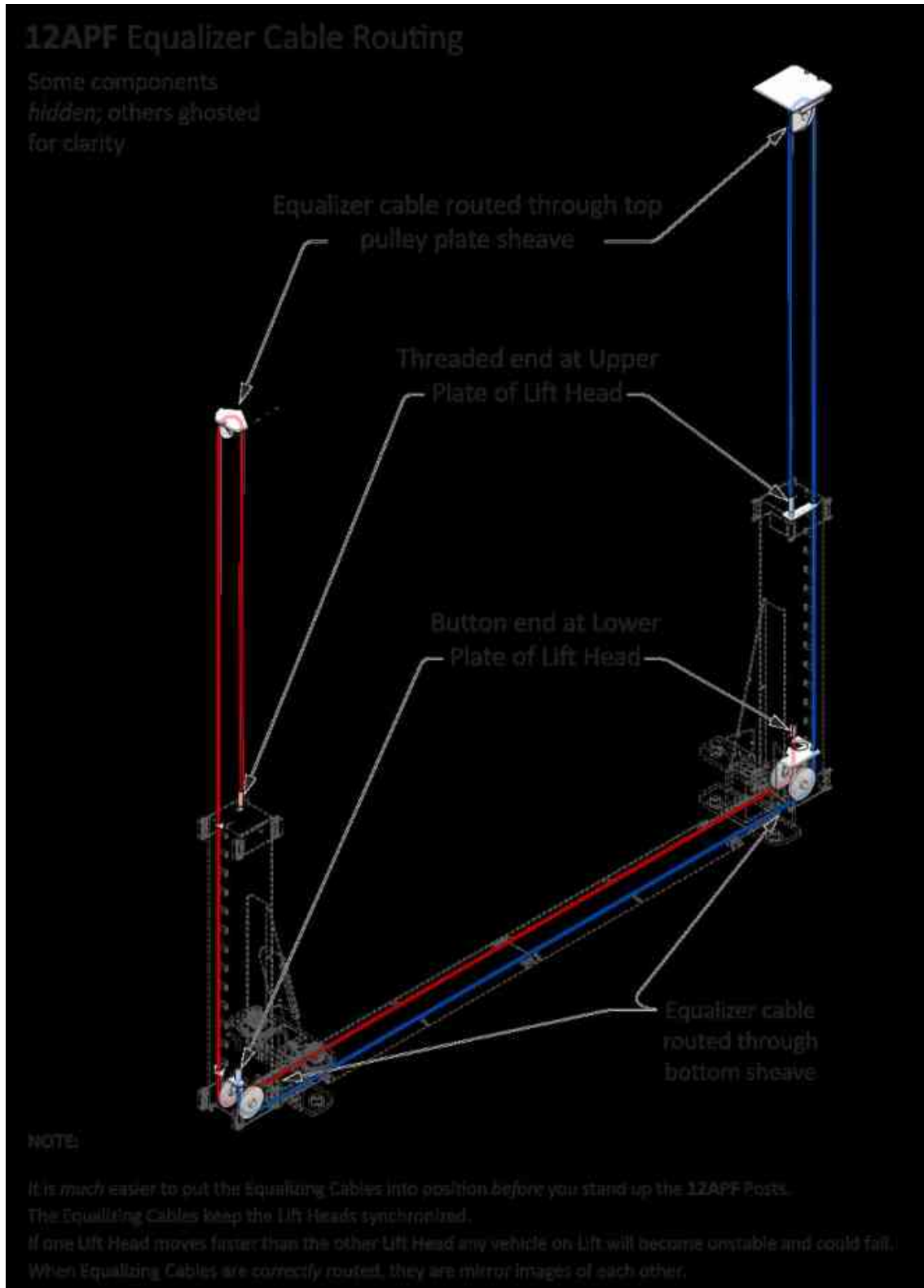

The figure below illustrates a 12APF Equalizing Cable. There is no wide/narrow configuration available on the 12APF Lifts.

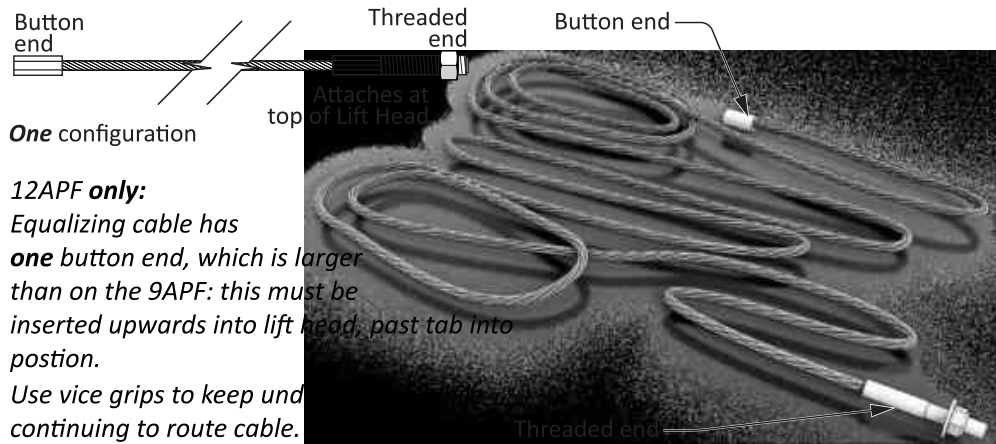

⚠ CAUTION BendPak recommends wearing gloves while handling the Equalizing Cables.

To put the Equalizing Cables into position 12APF:

1. Using a forklift or equivalent, move the Posts near the Chalk Lines.
2. Place both Posts either flat on the ground or with their tops elevated on a sawhorse or similar; the insides of the Posts need to be accessible, facing up.
3. Slide the Lift Heads away from the bottoms of both Posts by at least 24 in. (610 mm), to provide room to work.

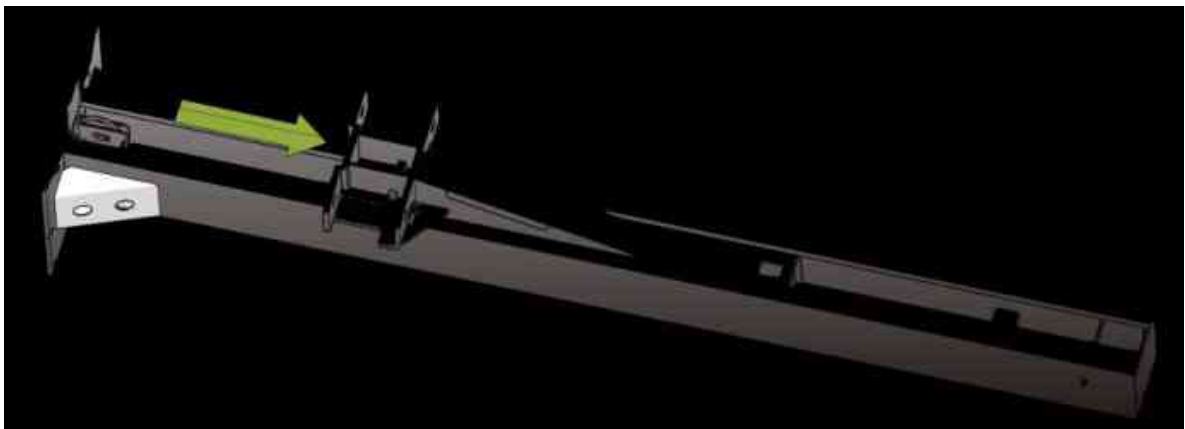

4. **12APF users:** remove the shipping plug from the Lift Cylinder port, then install a Nipple Fitting (5550095), making sure to use Thread Sealant on the NPT threads only.

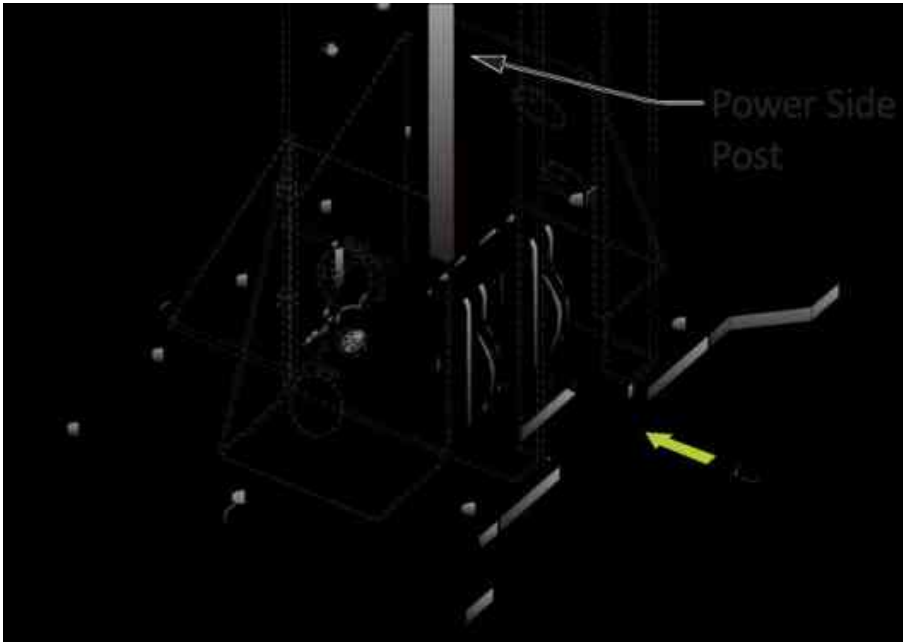

5. Remove the two Post Sheaves from the bottom of the Power Post. Keep the Cable Sheaves, Sheave Pins, and fasteners nearby; they will be re-installed.

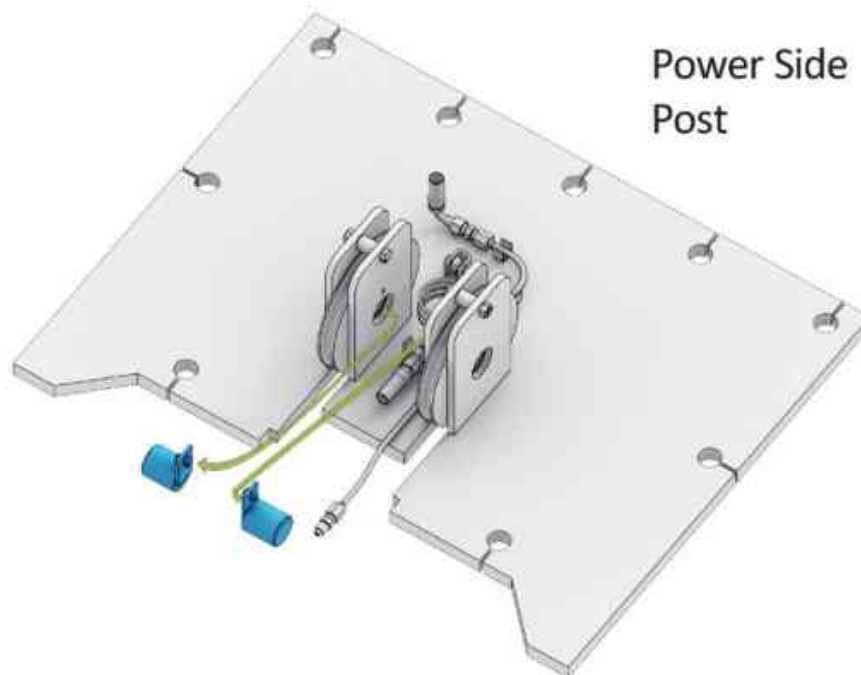

6. Locate the two Equalizing Cables.
The Equalizing Cables are the same length, so it does not matter which one you install first.
(5595857)
7. Secure the Button end at the Lift Head Lock Plate located inside each Lift Head.

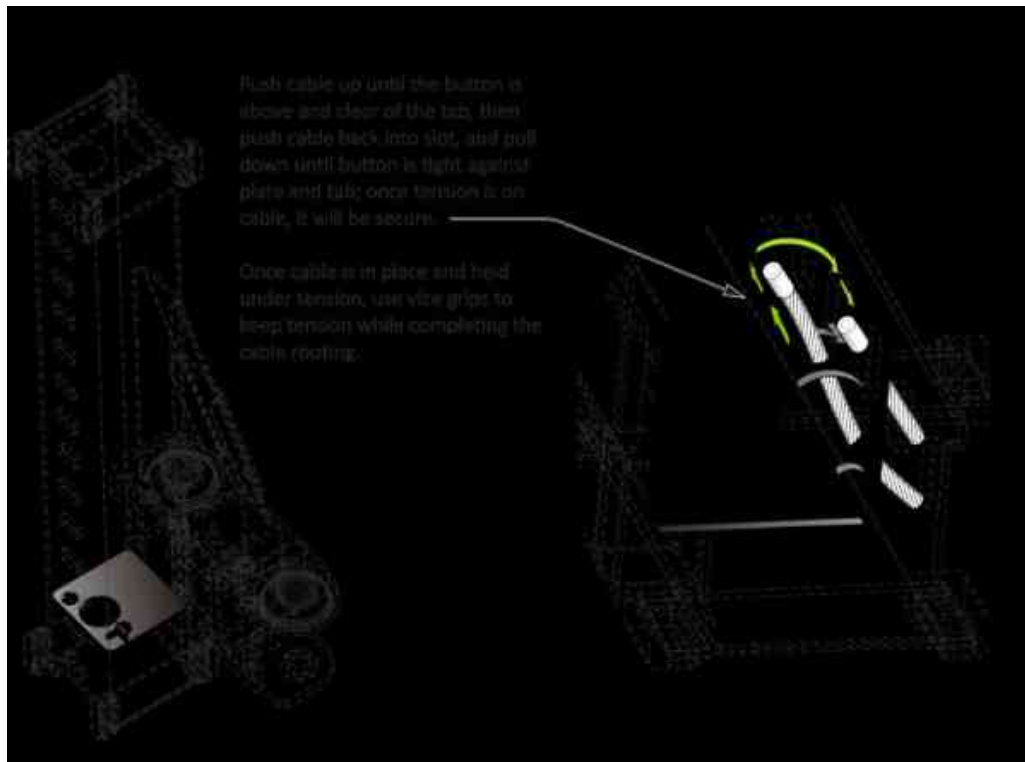

⚠ CAUTION Failure to secure the Button end may result in Lift malfunction.

8. Route the Cable down the Lift Post and around the Sheave at the bottom of the Post and out to the Opposite Post.
9. Route the Cable around the bottom Sheave and up towards and through the Lift Head.
10. Route the threaded end of the Cable *upwards* to the Top Plate Sheave.
11. Install the Top Plates on the top of the Posts and thread the cable around the Sheave and downwards towards the Lift Head. Refer to the figure below to assemble Top Plates.

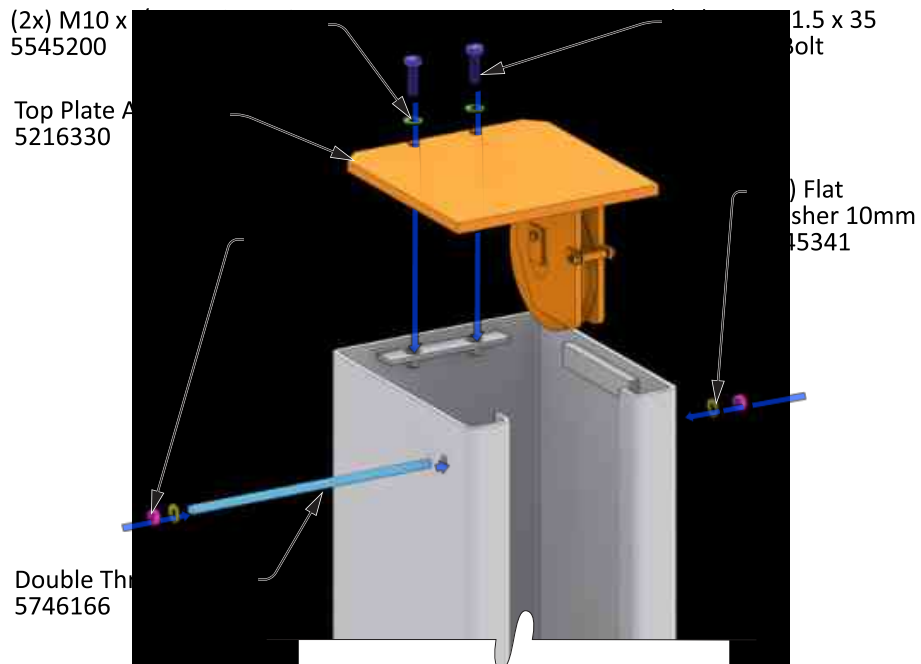

-
12. Insert the threaded end of the cable into the Cable Holder. Use the Washer and Nut to loosely secure the cable end to the Lift Head for now.

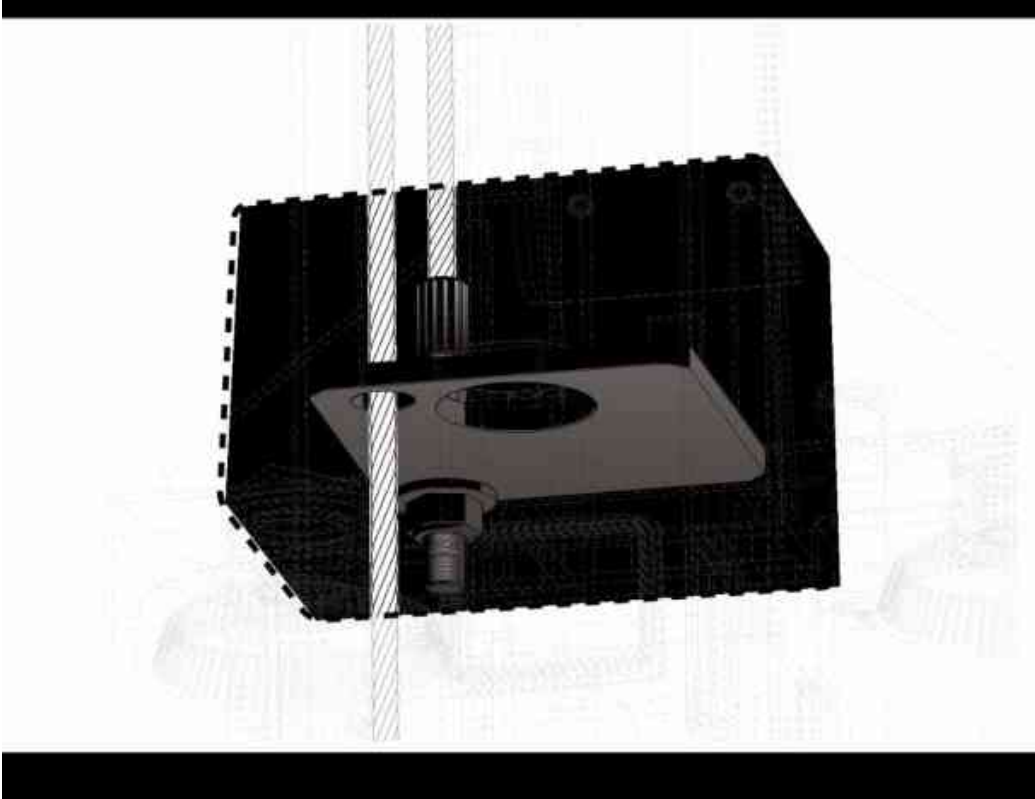

Remove Plug to access Cable Holder

13. Retrieve the remaining Cable and repeat the procedure beginning on the opposite Post.

It can be difficult to get the Button End into the Slot, as it may be hard to reach the Lock Plate. You may want to use a metal rod or a long tool to push the Button End into the Slot.



If you are having problems getting the Button end into the Slot, you might want to try pushing the Button end past the Lock Plate. Then move the Equalizing Cable around to get the cable into the Slot. Once the cable is in the Slot, pull on the other end of the cable to slide the Button end into the Slot; keep the cable taut until the Equalizing Cable is connected at the other end.

14. Apply Red Lithium Grease to the sheave pins.
15. After the Cables are in place, reinstall all sheaves and pins.
16. Verify the Top Plate at the top of each post is secured.
17. Carefully move both Lift Heads back down to the bottom of each Post, being mindful of pinch-points for hands *and* feet: even with the required steel toe boots, Lift Heads represent a pinch-point risk.
18. On **both** Lift Posts, locate the two Double Threaded Rods (M10 x 295 mm rods, threaded on both ends), and for each Threaded Rod gather the two Nuts and two Washers also in the Parts, put them into place through the top of each Post (they go all the way through the top of the Post), and tighten them in place on both ends. Refer to the figure on the previous page.

Anchoring the Posts

We strongly recommend having multiple people work together to install the Posts.

⚠ DANGER Pay **special** attention when installing the Posts. If done incorrectly, the Lift could fall over, potentially causing damage to the Vehicle, the Lift, and injuring bystanders.

Concrete specifications are:

- **Depth:** 9APF 4.25 in. (108 mm) minimum
12APF 6.5 in. (165 mm) minimum
Steel reinforced
- **PSI:** 3,000 psi (207 bar), minimum
- **Cured:** 28 days, minimum

Anchor Bolt specifications are:

- **Length:** 6.3 in. (160 mm)
- **Diameter:** .75 in. (19 mm)
- **Anchor torque:** 85 to 95 ft. lbs.
- **Effective embedment:** 3.25 in. (82.5 mm) or more

The concrete floor where you want to install your Lift must meet the following requirements:

- The floor must be a flat, steel reinforced concrete floor. It must be level; **do not install the Lift on a surface with more than three degrees of slope.**
- Do not install the Lift on cracked or defective concrete.
- Check the floor for the possibility of it being a *post-tension* slab. In this case, contact the building architect or the local department of building and safety before drilling. Using ground penetrating radar may help to locate the tensioned cable.

⚠ DANGER Cutting through a tensioned cable can result in injury or death. Do not drill into a post-tension slab unless the building architect confirms you are **not** going to hit a tensioned cable, or you have located it using ground penetrating radar. **If colored sheath comes up during drilling, stop drilling immediately.**

⚠ WARNING Your concrete and Anchor Bolts **must** meet these specifications. Only install your Lift on a concrete surface. If you install a Lift on asphalt or any other surface, or your concrete or Anchor Bolts do not meet these specifications, it could lead to product damage, Vehicle damage, personal injury, or even loss of life.

BendPak Lifts are supplied with installation instructions and concrete fasteners meeting the criteria as prescribed by the latest version of the American National Standard “Automotive Lifts – Safety Requirements for Construction, Testing, and Validation.”

⚠ WARNING Use only the ALI-certified Anchor Bolts that came with your Lift. If you use components from a different source, you void your warranty and compromise the safety of everyone who installs or uses the Lift.

Lift buyers are responsible for conforming to all regional, structural, and seismic anchoring requirements specified by any other agencies and/or codes, such as the Uniform Building Code and/or International Building Code. If the existing concrete floor does not meet the minimum requirements **BendPak strongly recommends consulting a concrete Specialist early in your planning process for the Lift installation.** The recommendations presented in this manual are generic in nature and cannot cover all situations. A concrete Specialist will adjust these recommendations to account for national, state, and local building codes as well as local weather conditions, soil composition, base preparation, load bearing, seismic requirements and any other structural concerns that may arise.

Effective Embedment is the location in the Hole where the Expansion Sleeve presses into the concrete. This is where the Anchor Bolts get their holding strength, the further down into the Hole, the greater the holding strength.

Nominal Embedment is how far down into the Hole the bottom of the Anchor Bolt is, which does not tell you anything about the holding strength.

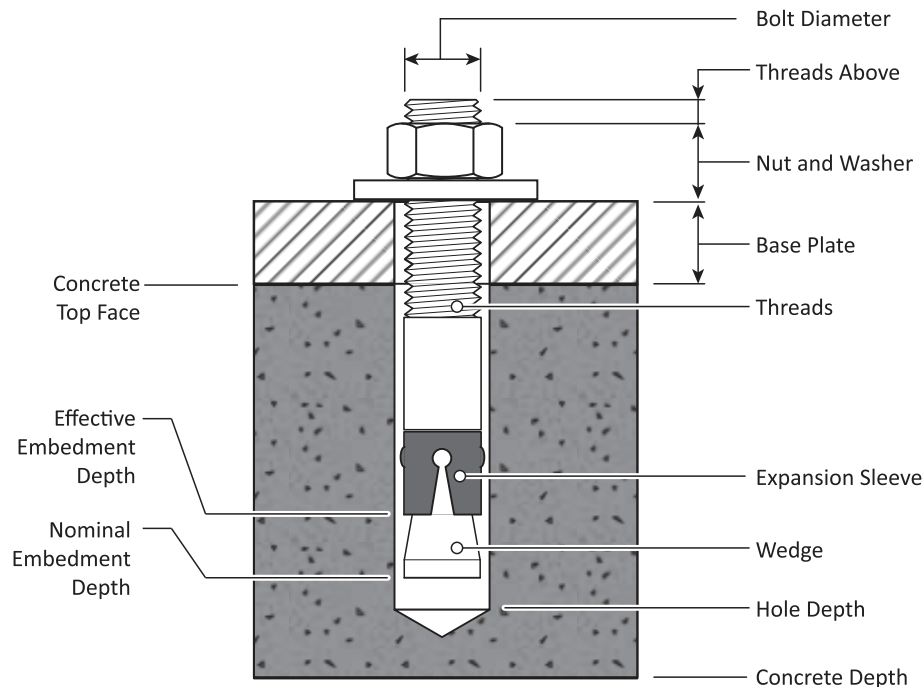

Not to scale. Components removed for clarity.

To install the Posts:

1. Using a Forklift or Shop Crane, move the Posts to the Chalk Line Guides you created earlier.
2. Stand up each Post, one at a time, and move it to the appropriate location.
3. Double check your measurements against the **Specifications** for your Lift model:
 - Distance from back of one Base Plate to back of the other Base Plate: **Width Overall** value
 - Distance from inside of one Post to inside of the other Post: **Inside Posts** value
4. Using the Base Plates as guides, drill each 9APF Anchor hole **4.5 in. (114 mm)** deep, and each 12APF Anchor hole **6.75 in. (172 mm)**; use a masonry bit.

Do not drill all the way through the concrete; if you punch completely through the slab, you could compromise the holding strength of the Anchor Bolts.

Drill in straight; do not let the drill wobble.

The diameter of the drill bit must be *the same* as the diameter of the Anchor Bolt. If you are using a 3/4 in. diameter Anchor Bolt, for example, use a 3/4 in. diameter drill bit.

5. Vacuum each hole clean. BendPak recommends using a Vacuum to get the hole very clean.

WARNING You must use the appropriate safety gear including safety glasses, dust masks, gloves, steel-toed work boots and heavy work clothes when anchoring the Posts.

You can also use a wire brush, hand pump, or compressed air; just make sure to thoroughly clean each hole.

Do not ream the hole. Do not make the hole any wider than the drill bit made it.

Important: The holding strength of an Anchor Bolt is partially based on the how cleanly the Expansion Sleeve presses against the concrete. If the hole is dirty or too wide, *there is less holding strength.*

6. Make sure the Washer and Nut are in place, then insert the Anchor Bolt into the hole.

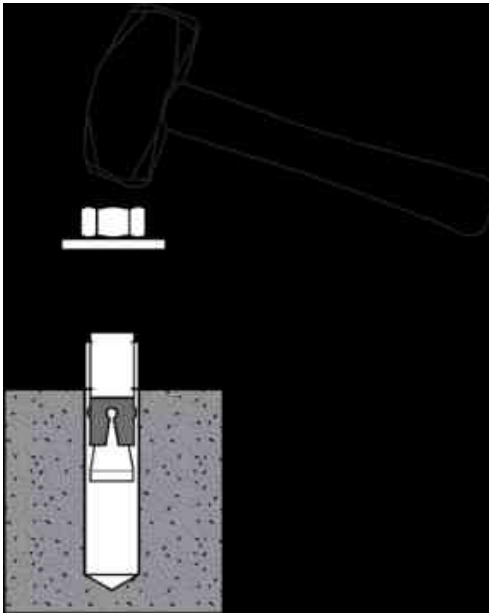

The Expansion Sleeve of the Anchor Bolt may prevent the Anchor Bolt from passing through the hole in the Base Plate; this is normal. Use a hammer or mallet to gently tap the Expansion Sleeve through the Base Plate and into the hole.

Even using a hammer or mallet, the Anchor Bolt should only go into the hole part of the way; this is normal. If the Anchor Bolt drops in with little or no resistance, the hole is too wide.

Once past the hole in the Base Plate, the Anchor Bolt eventually stops progressing down into the hole as the Expansion Sleeve contacts the sides of the hole; this is normal.

7. Hammer or mallet the Anchor Bolt the rest of the way down into the hole; stop when the Washer is snug against the Base Plate.

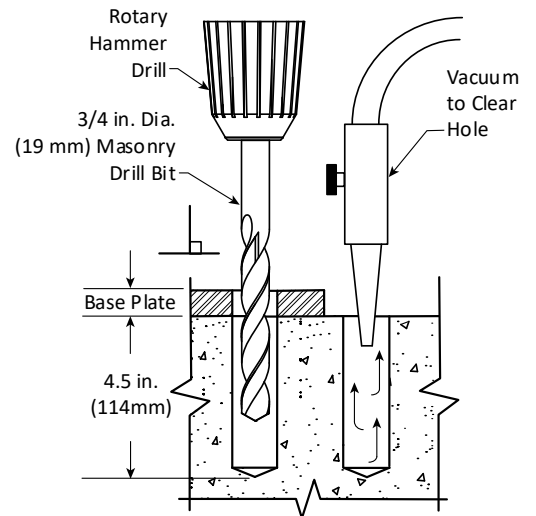

8. Plumb each Post; install optional Foot Guards if purchased, insert any required Shims while plumbing post. This is a good time to install optional Height Adapter Trays if purchased.

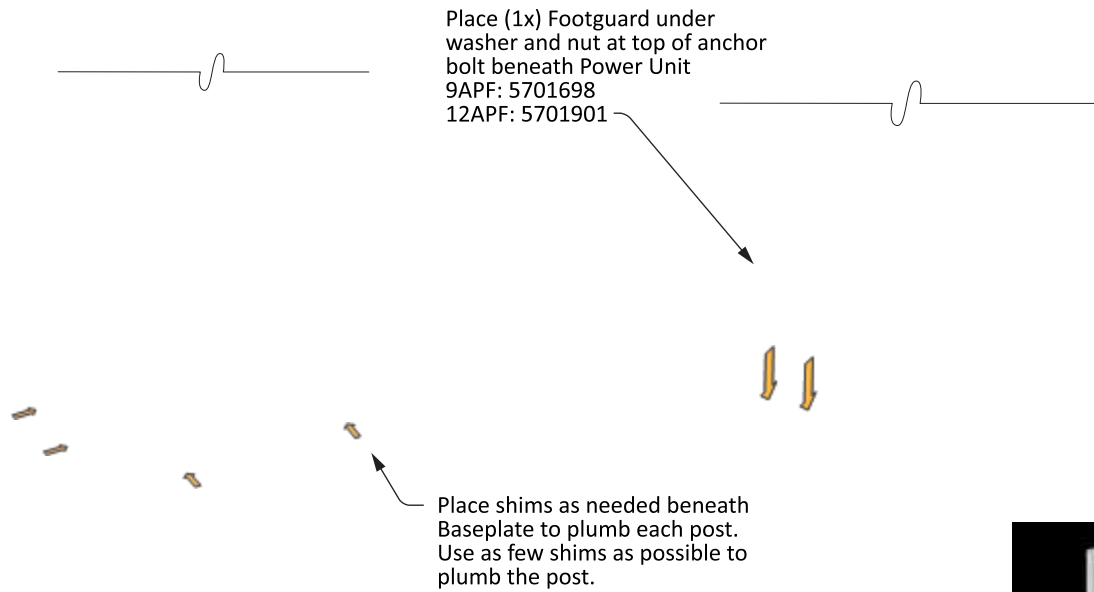

9. Wrench each Nut **clockwise** to the recommended installation torque, 85 to 95 ft. lbs., using a Torque Wrench.

Important: Do **not** use an impact wrench to torque the Anchor Bolts.

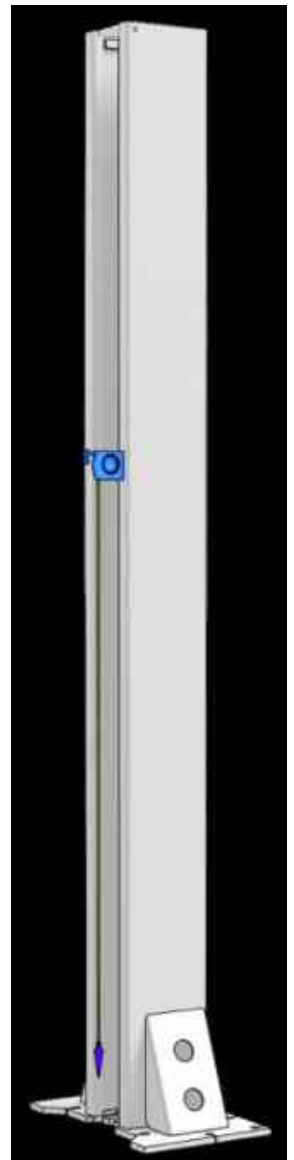
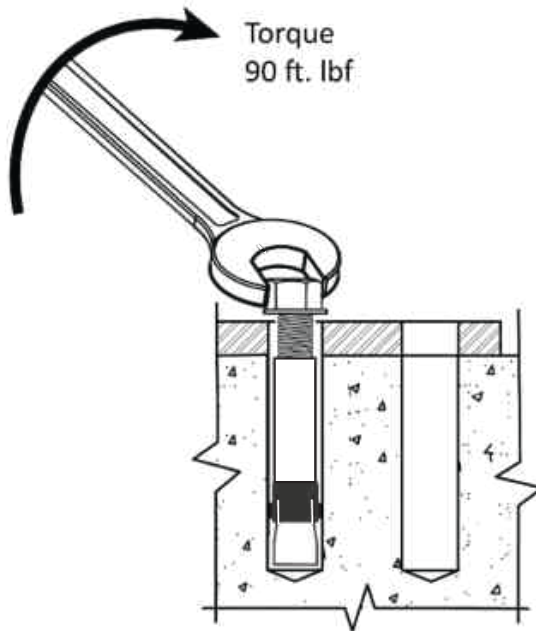

Routing the Safety Lock Cable

The following procedure describes how to put the Safety Lock Cable into place; it does **not** describe how to attach it to the Safety Lock Assemblies. As with the Equalizing Cables, most of these steps are far more easily accomplished with the posts lying down.

The following drawing shows the routing the Safety Lock Cable travels to each Safety Assembly.

Safety Cable Routing

(some components omitted or ghosted for clarity)

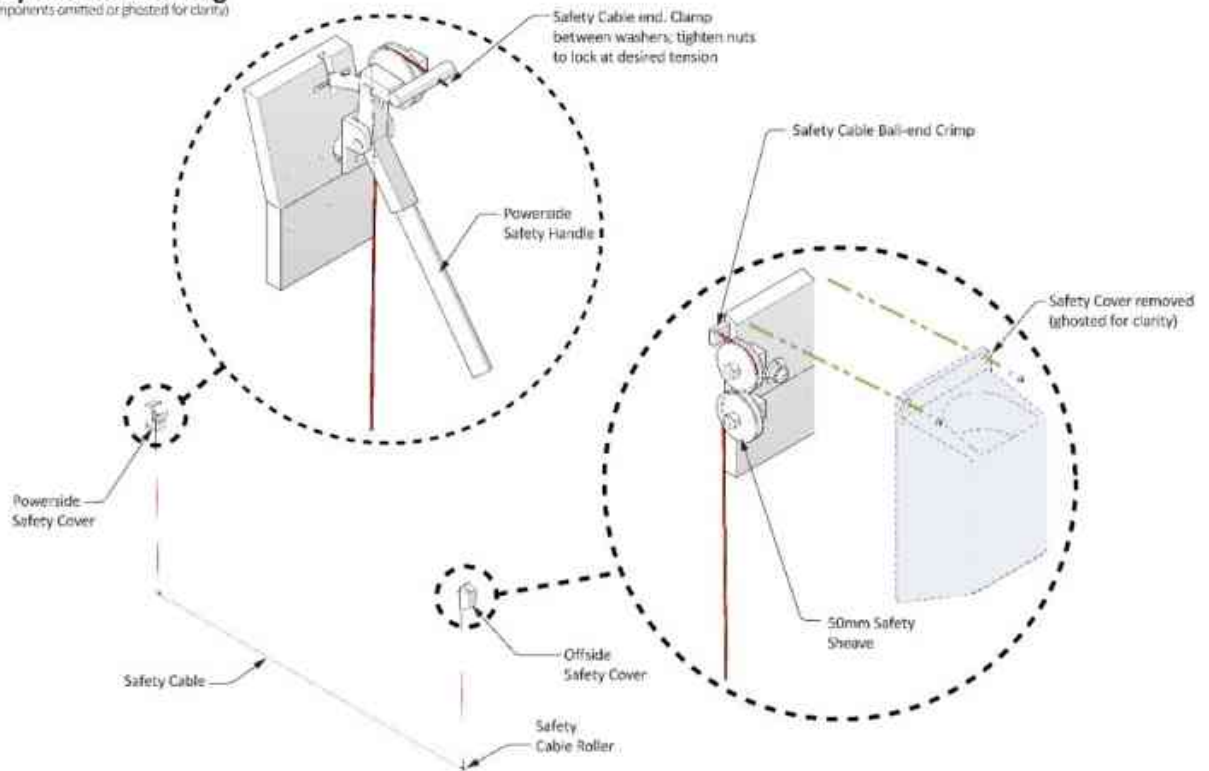

Drawing not to scale. Components removed for clarity. The Safety Assemblies are not installed at this point, so the Safety Lock Cable, after being routed, will simply stay in place until later in the installation.

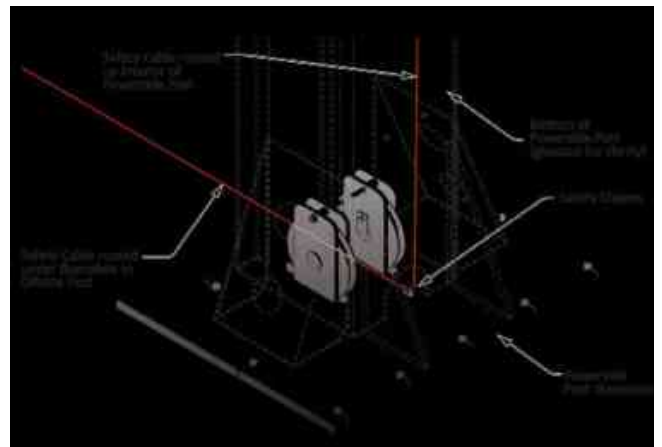
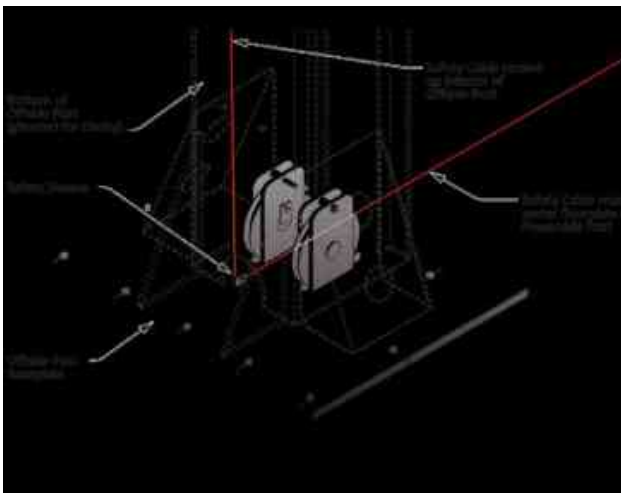

To route the Safety Lock Cable:

1. Locate the Safety Lock Cable for your Lift.
2. **Starting on the inside of the Off Side Post**, push the **non-ball** end of the Safety Lock Cable out through the opening in the Off Side Post, leaving the ball end inside the plate, with the non-ball end hanging out of the hole, ready for the next step.
3. Route that non-ball end of the Safety Lock Cable over the Safety Sheave, downwards on the inside of the Offside Post, under the Safety Sheave at the bottom of the Off Side Post, out and across towards the Power Side Post underneath the Lift floor plate, under the Safety Sheave at the bottom of the Power Side Post, then upwards, on the inside of the Power Side Post, towards the Mounting Bracket.
4. **On the Power Side Post**, when the **non-ball end** of the Safety Lock Cable is near the Mounting Bracket, route it over the Safety Sheave, then push it through the opening in the Power Side Post.
5. The Power Side Safety Assembly is not yet installed, so just leave the non-ball end of the Safety Lock Cable hanging out of the hole. Both ends of the Safety Lock Cable will be appropriately connected during the procedure to install the Safety Assemblies.

 **CAUTION** When connecting the ends of the Safety Lock Cable later in the installation, make sure the Cable stays properly seated in all the Safety Sheaves. This keeps it out of the way of the Hydraulic Hoses and Equalizing Cables.

Connecting the Safety Lock Cable

Your Lift has two Safety Assemblies: one on the Power Side Post (above the Power Unit) and the other on the Offside Post.

The Safety Assemblies disengage the Lift's Safety Locks so the Lift Arms can be lowered. The Safety Assemblies need to be disengaged at the same time so that the Lift Arms lower together. In order to accomplish this, the two Safety Assemblies are connected to each other via the Safety Lock Cable.

Routing the Safety Lock Cable was done earlier; refer to [Routing the Safety Lock Cable](#) for additional information.

Safety Handle Assembly

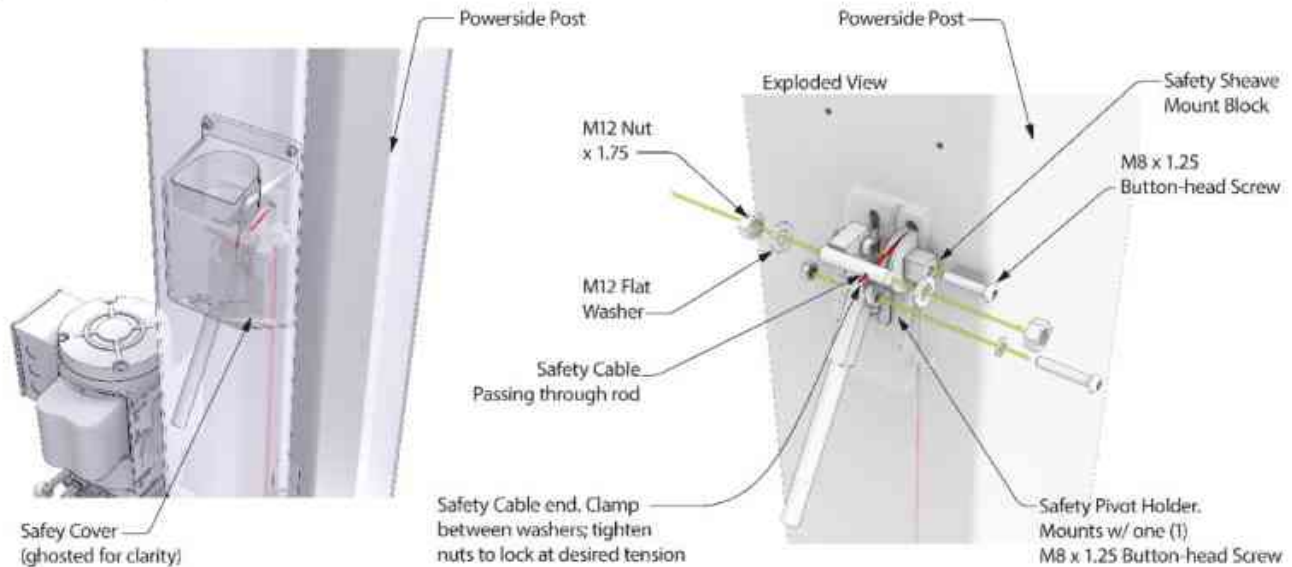

The **Power Side Safety Assembly** includes a Safety Lock Release Handle, which angles down and is used to lower the Lift.

The **Off Side Safety Assembly** is mostly the same as the Power Side Safety Assembly, except that it does not have a handle.

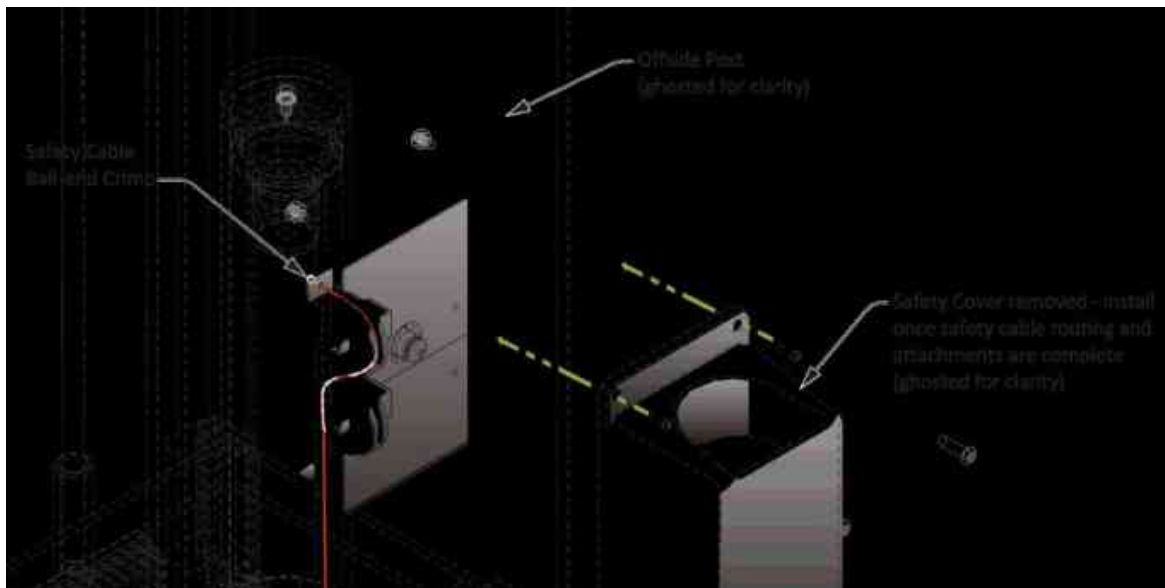

The procedures for installing the Power Side Post and the Offside Post Safety Assemblies are similar, but not exactly the same.

Use the illustrations on the previous pages to complete the procedures below.

To install the two Safety Assemblies:

1. **Starting on the Power Side Post**, locate the Safety Assembly **with** the Safety Lock Release Handle with integrated Safety Stud, five (5) M8 Button Head, Safety Pivot Holder, two (2) M12 Washers, two (2) M8 Washers, two (2) M12 Nuts, and five (5) M8 Nuts. Note Mounting Block welded to the Post.

Refer to the previous drawings for locations of the components of the Safety Assemblies.

2. Mount Safety Pivot Holder on the Post, using the button-head screw in place in the Post.
3. Use another M8 Button Head Screw through the Safety Pivot and the Safety Handle's Pivot Point to secure the Safety Handle to the Safety Pivot.
4. Insert an M8 Button Head Screw through the Mounting Block(s), passing through the Safety Sheave(s) and terminating in an M8 Nut.
5. Prepare the threaded Safety Stud (integrated onto the Safety release Handle) with Washers and Nuts threaded and in position, but loose enough that they do not obstruct the small hole which is the Safety Cable's path through the Safety Stud.
6. Repeat Step 4 for each of the Offside Safety Assembly's Safety Sheaves on the Offside Post.
7. Install Safety Covers on each Post once all other Safety assembly setup is complete.

To connect the Safety Lock Cable:

1. **Starting on the Offside Post**, route the ball end of the Safety Cable through the small plate, over the upper Safety Sheave, around and under the lower Safety Sheave.
2. Secure the Safety Cable under enough tension to prevent it from sliding around.
3. **Moving to the Power Side Post**, screw two Nuts and Washers onto the threaded end of the Safety Stud. Make sure that one Nut and one Washer is on each side of the hole in the Safety Stud.
4. Pull the non-ball end of the Safety Cable over the Safety Sheave and into the hole in the Safety Stud, between the two Nuts and the two Washers.
5. Pull firmly enough to take slack out of the Safety Cable, but not firmly enough to stretch the cable, and then tighten the Nuts to lock into place.

⚠ CAUTION When tightening the Nuts, keep tension on the Safety Cable and keep the Safety Cable centered between the two Nuts.

6. Operate the Safety Lock Release Handle, checking for proper operation of both Safety Assemblies.

⚠ DANGER

Verify that both the Power Side and the Offside Safety Assemblies engage properly **before** operating the Lift.

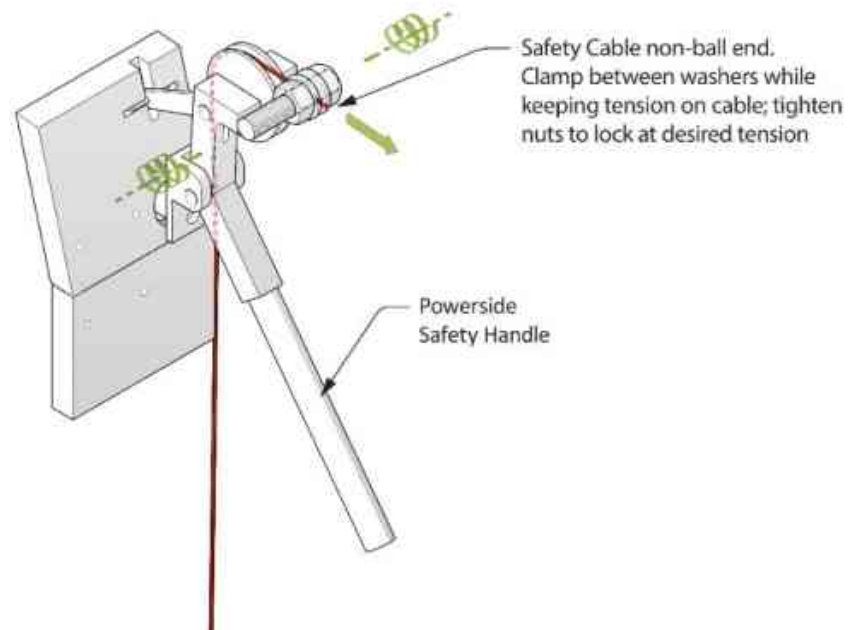

Hydraulic Contamination



IMPORTANT! PLEASE READ NOW



Hydraulic Fluid Contamination poses a serious issue for your Lift; contaminants such as water, dirt, or other debris can get into the Hydraulic Hoses and Fittings on the Lift, making your new Lift *inoperable* and *unusable*.

Your Lift is shipped with clean components, however, BendPak strongly recommends that you take secondary precautions and clean all Hydraulic Hoses and Fittings prior to making connections. It is better and less costly to take these extra steps now so that you do not need to take your Lift out of service later to fix issues that could have been prevented at the time of installation.

There are several ways to clean Hydraulic Hoses and Fittings:

- **Compressed Air.** Use an air compressor to blow out contaminants from each Hydraulic Hose and Fitting prior to installation. Clean, dry air is preferred. Wear ANSI-approved eye protection (safety glasses, goggles, or face shield) when using compressed air for cleaning. Never point an air hose nozzle at any part of your body or any other person.
- **Fluid Flushing.** As long as the Hydraulic Fluid is clean and compatible with the system fluid, you can flush Hoses and Fittings to create turbulent flow and remove particulates. Always ensure that the fluid itself is contaminant-free.



Some additional steps that will help keep the Hydraulic Fluid clean:



- **Remove old thread seal tape.** Some ports on the Hydraulic Cylinders are shipped with temporary plugs secured with thread seal tape, so make sure to thoroughly remove any leftover thread seal tape that may inadvertently enter the Hydraulic System.
- **Use a liquid thread sealant only.** Liquid thread sealant (Loctite™ 5452 or similar) is recommended. Do not use thread seal tape on any fitting. Liquid thread sealant is recommended for NPT connections, fine for JIC connections, but is *not* necessary for O-ring (ORB) connections.
- **Always use clean equipment.** If you use a dirty bucket or funnel to transfer the Hydraulic Fluid into the Hydraulic Fluid Reservoir, the contaminants will likely be introduced into the Fluid. When using cleaning rags, use a lint-free rag.
- **Proper storage.** Keep the Hydraulic Fluid sealed in its container until ready for use; store the Fluid in a clean, dry, and cool area.
- **Cover the Hoses and Fittings.** Before installation, *do not* leave the ends of the Fittings exposed; the same applies for the Hydraulic Hoses. As a general rule, keep the Hydraulic Hoses and Fittings capped and in a clean area until ready for use.
- **Filter the new Hydraulic Fluid.** Just because it is new does not mean it is *clean*. Use an offline filtration cart or kidney loop system to make sure the Hydraulic Fluid is clean before being transferred into the Hydraulic Fluid Reservoir (even using a heavy-duty nylon mesh screen is better than trusting what is left at the bottom of the barrel).
- **Avoid mixing different types of Hydraulic Fluid.** If Hydraulic Fluid needs to be replaced, make sure to flush the Hydraulic System of the old Hydraulic Fluid before you add the replacement Fluid; do not mix the two together.

Hydraulic System Safety Warnings

Before applying power to the Hydraulic System note the following Safety Warnings:

 **DANGER** Failure to observe these warnings can result in serious personal injury including, in rare cases, death.

 **DANGER**  The Power Unit is a Hydraulic Pump capable of developing pressures in excess of 5,000 psi (345 BAR). A pressure relief valve is used to set the pressure at the desired level. Tampering with, adjusting, modifying, or removing the relief valve is extremely dangerous and is not permitted. Only trained Hydraulics technicians are permitted to adjust the relief valve, using calibrated hydraulic pressure gauges to ensure the proper pressure setting is achieved.

 **DANGER**  Changes to the output pressure may render the power unit incompatible with pressure limitations of other components in the hydraulic circuit. This may cause catastrophic failure of those components, and could result in property damage, severe personal injury, or death.

 **DANGER** The Hydraulic System can contain high pressure which, if suddenly released, can cause severe injury or death.

 **WARNING** The Hydraulic hoses and connections **must** be inspected before any attempt to raise a Vehicle is made.

 **WARNING** **Verify** all Hydraulic Hose connections and fittings, including unused auxiliary port plugs on the Power Unit, the Flow Divider, the Cylinders and anywhere else in the Hydraulic System are tightened.

 **WARNING** Changes to the output pressure may render the power unit incompatible with pressure limitations of other components in the hydraulic circuit. This may cause catastrophic failure of those components, and could result in property damage, serious personal injury, or death.

 **WARNING** Do **not** attempt to connect or disconnect Hydraulic Hoses while the equipment is loaded or while a Vehicle is on the Lift, or the Hydraulic System is under pressure.

 **WARNING** Keep bare hands away from Hydraulic Fluid; always wear gloves when handling Hydraulic Fluid, Cylinders or Hydraulic Hoses.

 **WARNING** When handling Hydraulic Fluid, always observe the manufacturer's safe handling instructions found in their Material Safety Data Sheet (MSDS).

 **WARNING** **Always** promptly clean any Hydraulic Fluid spills. If a leak is the source of the spill, lockout the Lift to prevent use until the Hydraulic System is repaired.

About Thread Sealants

Liquid Thread Sealant lubricates and fills the gaps between the Fitting threads and leaves no residue that could contaminate the Hydraulic Fluid. Other types of Thread Sealants (like Teflon Tape) can shred during installation or removal and eventually enter the Hydraulic System. Thread Sealant can be used with most Hydraulic Fittings, although you probably only need to use it with NPT connectors.

To apply Thread Sealant:

1. Apply the thread sealant when the ambient temperature is between +46.5°F to +70°F (+8°C to 21°C).

Make sure the Fittings and connectors you are going to use are clean and dry.

2. If you are adding Thread Sealant to a Fitting or connector that has already been used with a different sealant, use a wire brush to thoroughly remove the old sealant before adding more.
3. Skipping the top thread, apply a small amount of Thread Sealant to the next four threads of the Fitting.

⚠ WARNING Always wear the proper protective equipment when handling Thread Sealant.

You only need a small amount because the sealant spreads to the other threads as it is tightened into place.

If you put too much, the excess liquid will be pushed out when the Fitting is tightened; use a rag to wipe the excess.

4. Tighten the Fitting into the connector; do **not** over tighten the Fitting.
5. Allow whichever is greater: 24 hours, or the manufacturer-recommended curing time, before pressurizing the system.



Routing the Hydraulic Hoses – 9APF

1. **9APF users:** remove the shipping plug from the Lift Cylinder port, then install an Elbow Fitting (5550086), making sure to use Thread Sealant on the NPT threads only.

9APF:

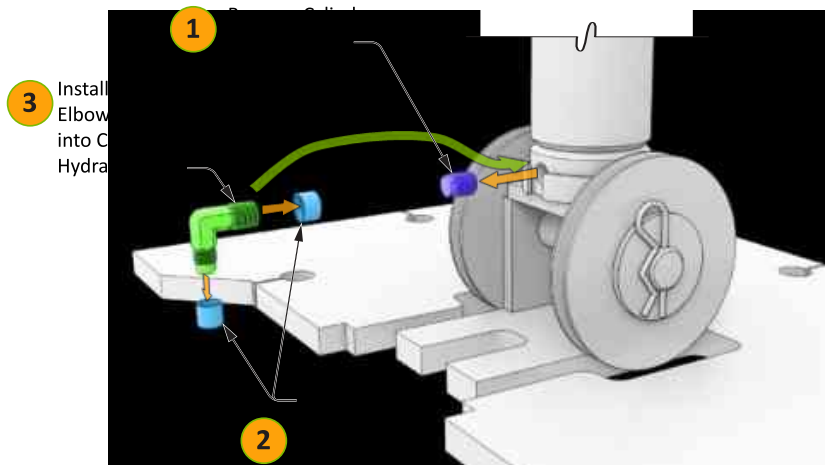

Routing the Hydraulic Hoses – 9APF

Hydraulic Hoses move Hydraulic Fluid to and from the Hydraulic Cylinders at the bottom of each Post. Refer to the figure below when connecting the Hydraulic Hoses to the Hydraulic Cylinders on the 9APF.

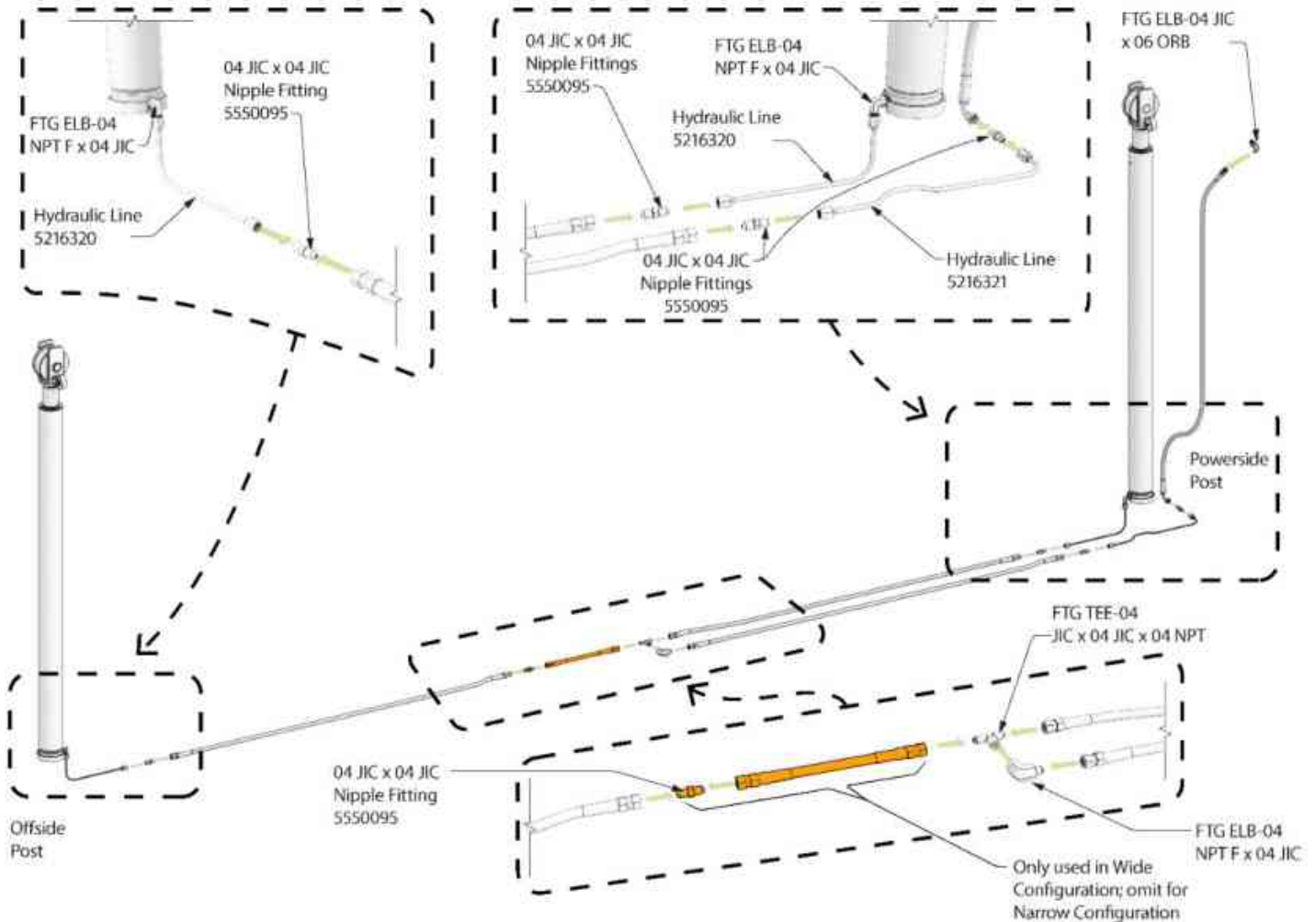

Not to Scale. Components removed for clarity.

Routing the Hydraulic Hoses - 12APF

Hydraulic Hoses move Hydraulic Fluid to and from the Hydraulic Cylinders at the bottom of each Post. Refer to the figure below when connecting the Hydraulic Hoses to the Hydraulic Cylinders on the 12APF.

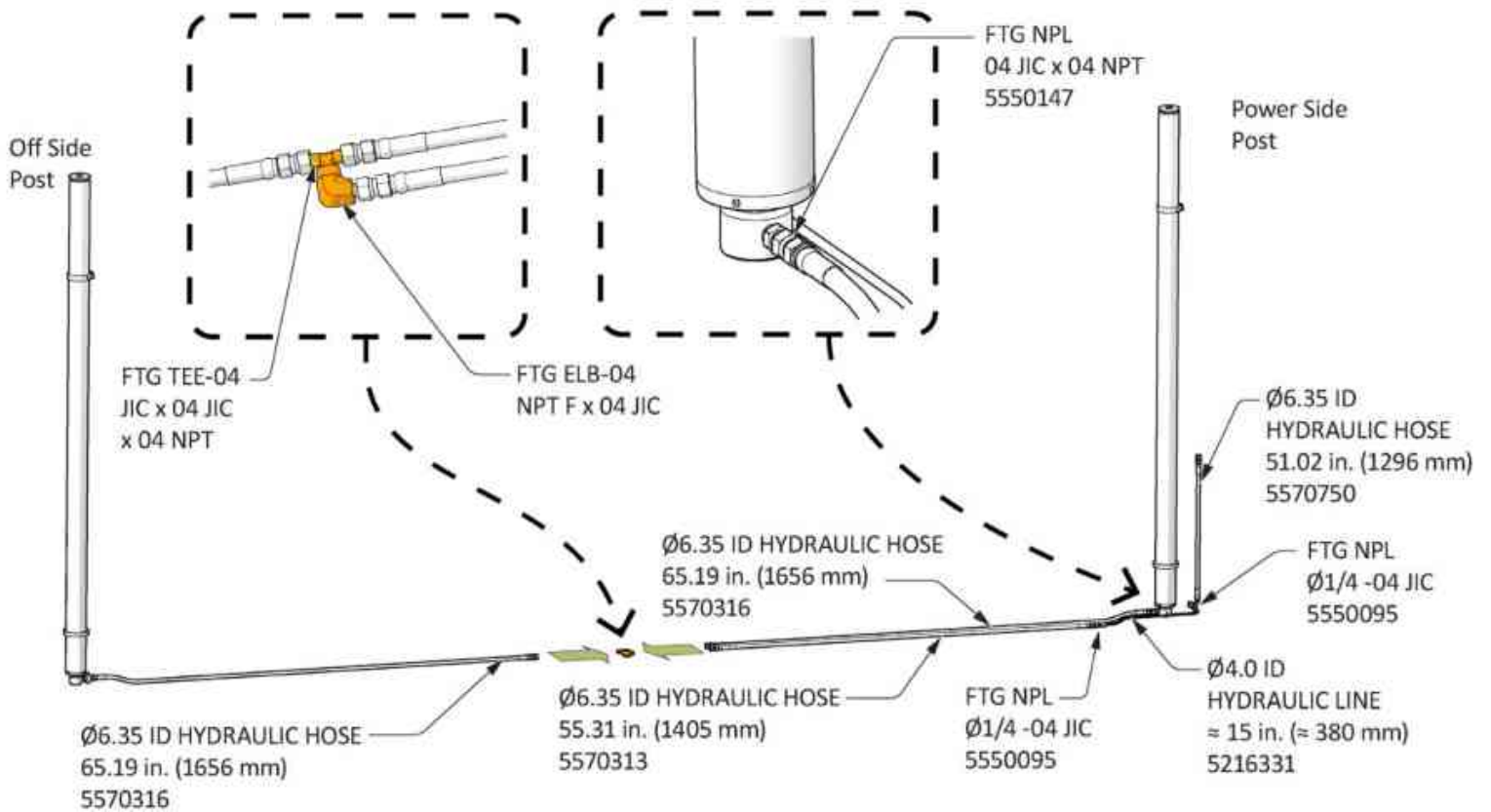

Not to Scale. Components removed for clarity.

Mounting the Power Unit

This section describes how to mount the Power Unit on the Lift. An Electrician is *not* required to **mount** the Power Unit, but *is* required to **connect** the Power Unit to the facility's electrical service.

Important: Do *not* connect the Power Unit to the Hydraulic System or to the power source at this point in the installation; those connections will be made later.

The Power Unit **must** be mounted on the Mounting Bracket on the Power Side Post.

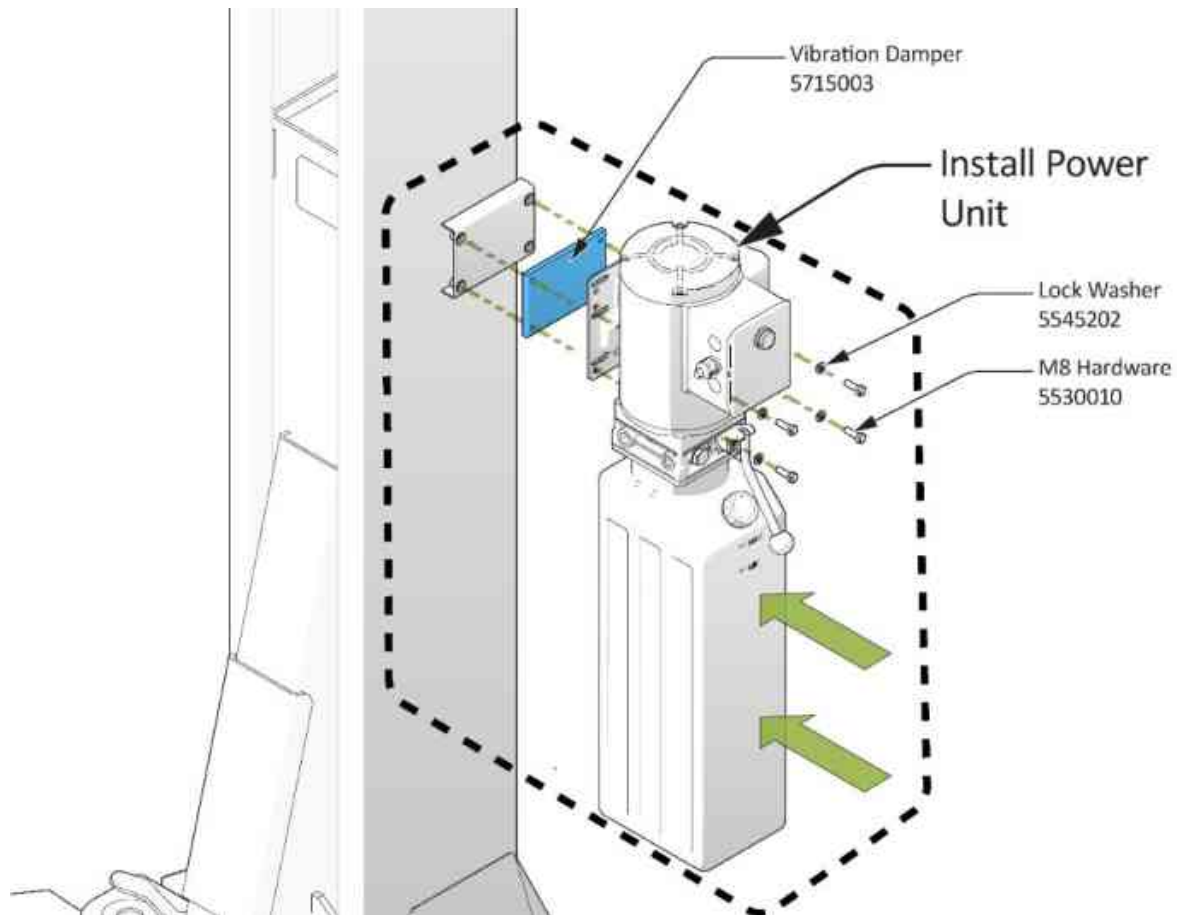

To mount the Power Unit to the Power Side Post:

1. Find the supplied M8 hardware and the Vibration Dampener.
2. Carefully remove the Power Unit from the shipping material.

CAUTION The Power Unit is heavy. BendPak recommends having one person hold the Power Unit while a second person bolts it into place.

3. Position the Vibration Dampener into place next to the Mounting Bracket on the Power Side Post.
4. Move the Mount Plate on the back of the Power Unit next to the Vibration Dampener.
5. Push one of the Bolts through its washer and through a hole in the Mount Plate, through the Vibration Dampener, and into the Mounting Bracket; tighten the Bolt into the receiving rivet nut.
6. Repeat Step 4 for the other three Bolts.

Connecting the Hydraulic Hoses

Some of the Hydraulic Lines were put into place much earlier in the installation. It is now time to finish routing and installing them.

This section covers connecting the Elbow Fitting that connects to the Power Unit.

The following procedure assumes the Hydraulic Lines were put into position earlier in the installation. Refer to **Routing Hydraulic Lines** for more information. If they were **not** put into position earlier, you must do so now, **before** beginning the following procedure.

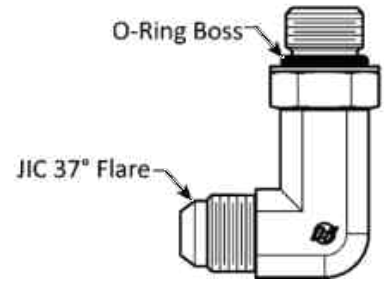

To finish connecting the Hydraulic Lines:

1. Locate the Short Hydraulic Line and the remaining Elbow Hydraulic Fitting.
2. **On the Power Unit**, locate a hydraulic pressure out port on the Power Unit (**P1** or **P2**), remove the shipping plug. Place a few drops of hydraulic fluid on the O-Ring of the Elbow Hydraulic Fitting (06 ORB to 04 JIC) and install it in the P1 or P2 port of the Power Unit.
3. The figure below shows the location of the P1 Hydraulic Pressure Port on a typical Power Unit available for the 9APF & 12APF Lifts.
4. Connect the Hydraulic Hose to the Elbow just installed.

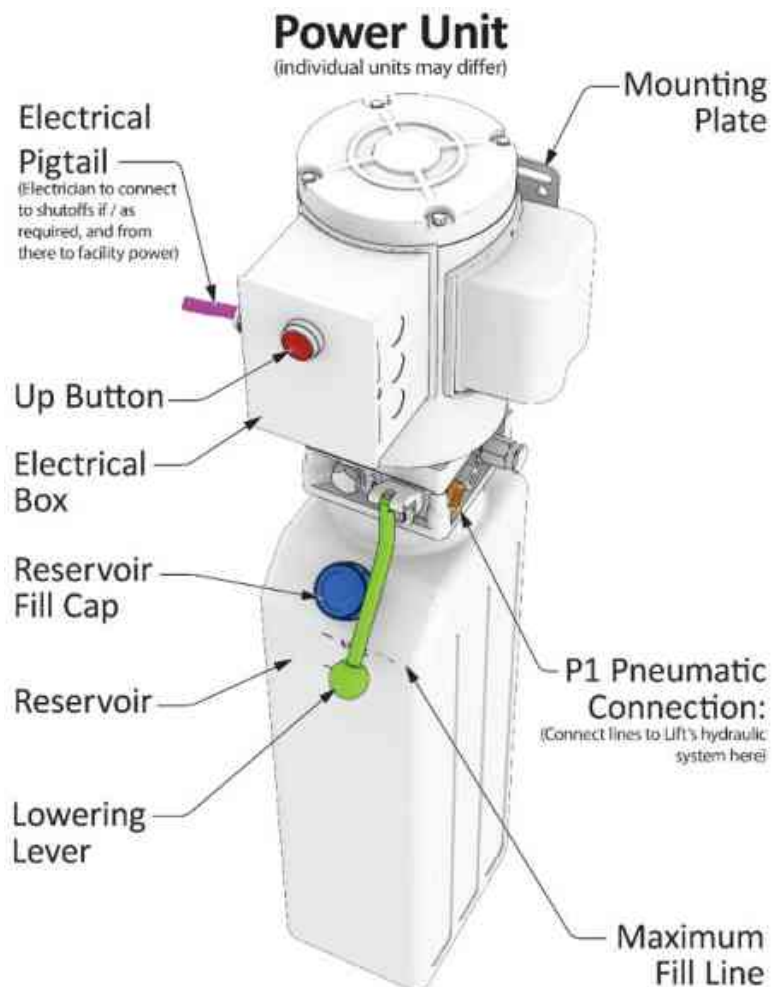

About ASARS

Automatic Swing Arm Restraint System full circle stop gears are integrated into each Lift Arm.

The ASARS Full Circle Stop Gears are intended to hold the Lift Arms in place laterally (once they mesh with the Lift Arm Gears) as the Lift Arm rises from the ground up to where the Lift Pads contact the manufacturer's recommended Lifting Points.

When the Lift is fully lowered, the ASARS Full Circle Stop Gears are **not** meshed with the Gears on the Lift Arms. This allows lateral, angular movement for the Lift Arms to position them correctly under the Vehicle. When the Lift begins to rise, the Full Circle Stop Gears mesh with the Lift Arm Gears.

Full Circle Gears & Lift Arm Gears

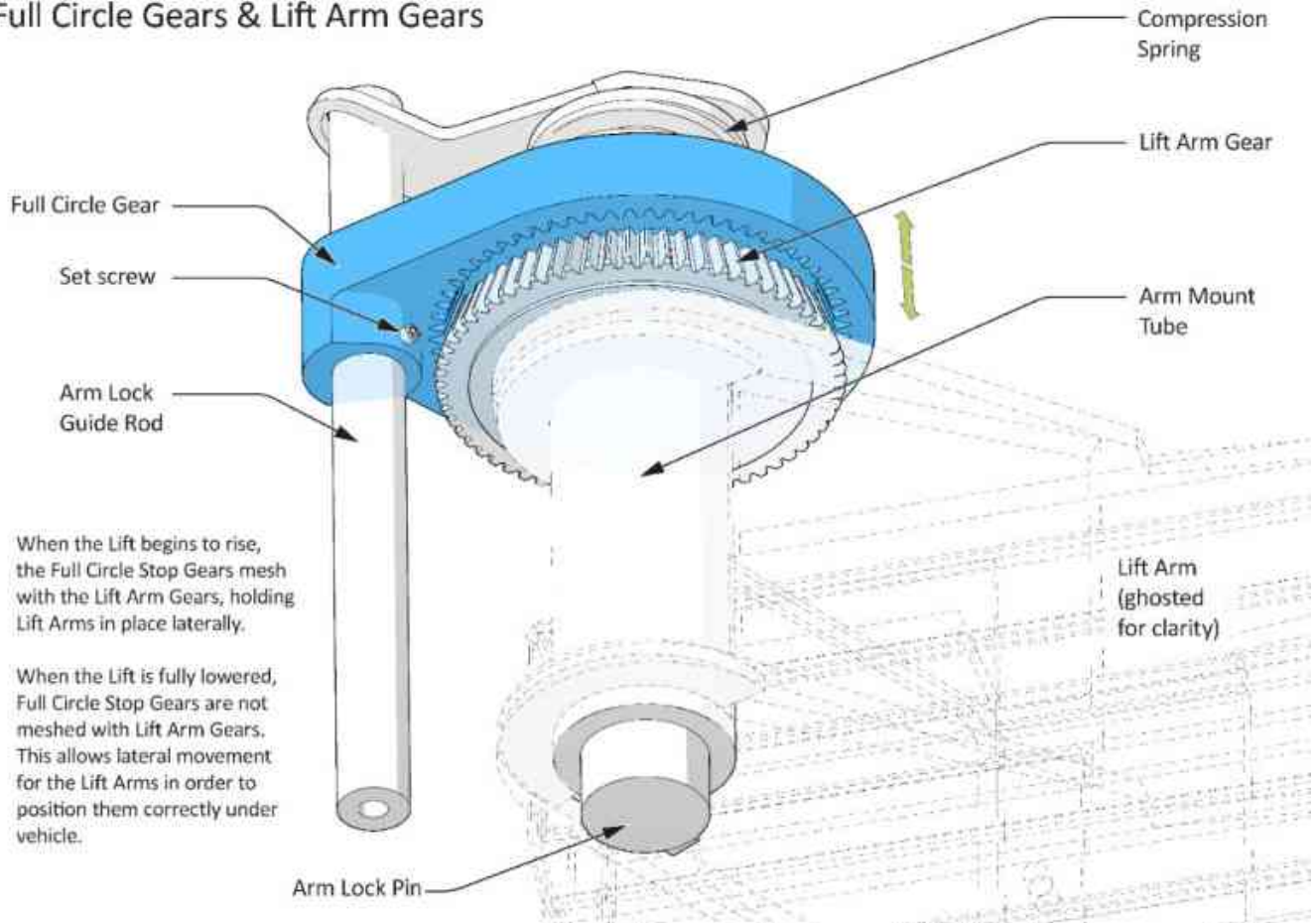

Installing Lift Arms

Lift Pads on the end of the Lift Arms contact the Vehicle's Lift Points to raise it off the ground.

The Lift is delivered with four Lift Arms. Two arms are asymmetric and two are straight. The Lift Arms may be mounted on the front or rear of the Lift.

The Asymmetric Arms are designed to be mounted on either the Left or Right side of the Lift.

There are several rules that govern which Lift Arms go where on a particular Lift.

To determine the Front and Rear of the Lift:

- If you can only drive in one way. The approach side is the Rear, the other side is the Front.
- If you can drive in either way. Choose one side as the Front and the other side as the Rear.

The best way to make this decision is to pick one approach direction for the Vehicles you will be putting on the Lift, even though you can drive in either way. Once the decision is made, you approach the Lift from the Rear, so the other side is the Front.

Determine whether the Lift Arm is a 'right' or a 'left.' This is determined separately per Post.

To determine right and left, stand between the two Posts, then turn to face one of them straight on. From this viewpoint, the right side of the Post is the 'right' and the left side of the Post is the 'left.'

After installing the Lift Arms on the first Post, repeat the process for the second Post.

To install a Lift Arm in a Lift Head:

This illustration depicts installing one Lift Arm to its Lift Head for simplicity; *repeat* this same process for *each* arm. Other components hidden or ghosted for clarity.

- 01 **Lift & Remove** Arm Lock Pin and Arm Lock Guide Rods to allow Lift Arm to slide into place.

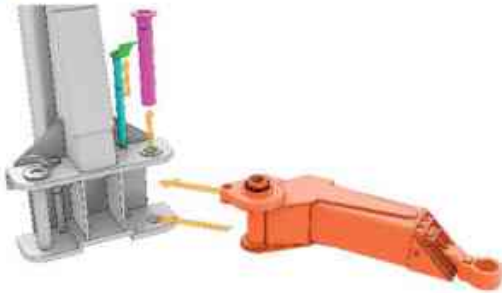

- A **Prior** to connecting lift arms to Lift Head, set Lift Arm(s) nearby, ready to connect.
*Note bent pin holding Compression Spring in place.



- 02 **Lower** Arm Lock Pin to rest on bent pin holding Compressed Spring.



- 03 **Remove** bent pin holding Compressed Spring, allowing Arm Lock Pin to slide down into place.



- 04 **Lower** Arm Lock Guide Rod to slide down into place; once all are placed, insert set screw to **hold** Full Circle Stop Gear in place on Arm Lock Guide Rod.

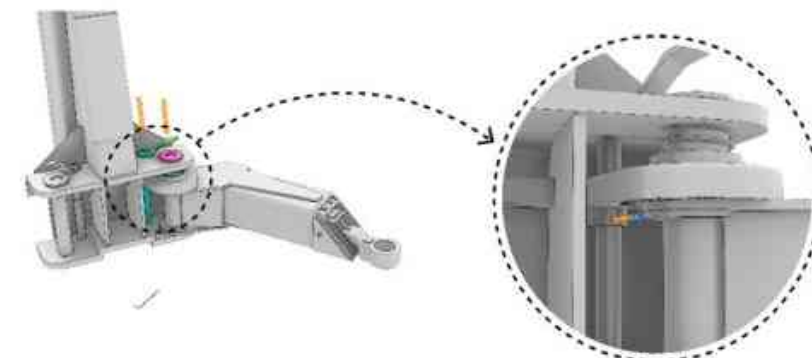

Install the Cylinder Clamps 12APF Only

⚠ WARNING Verify the cylinder clamps are positioned at the top of the lift head and secured one on **each** cylinder! **Do not operate the Lift if the cylinder clamps are not secured on the hydraulic cylinders.**

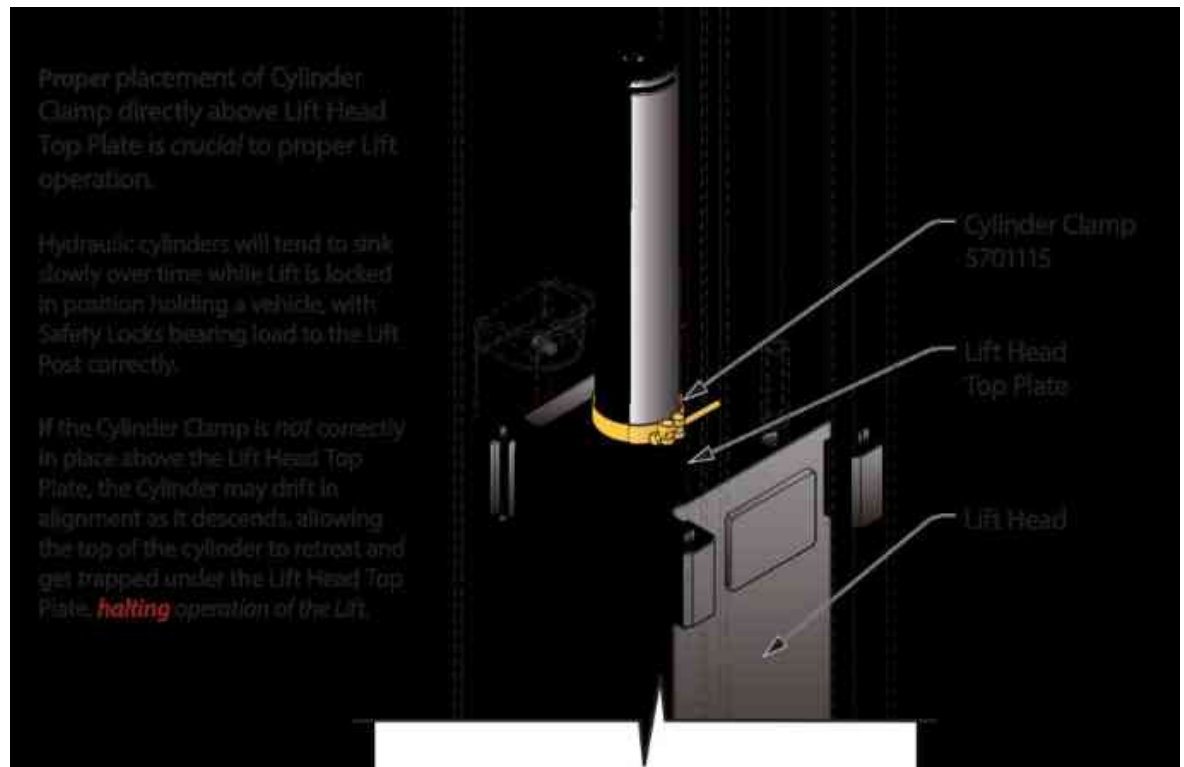

Electrical Information

Contacting the Electrician

A licensed Electrician must be available at some point during the installation. There are many legitimate variations in wiring, local codes, and downright dangerous errors out in the real world that cannot be addressed in this manual. A licensed electrician has the proper equipment and training to ensure a safe installation.

Notify the Electrician *in advance* so that they arrive prepared with appropriate components for connecting to the power source, a Power Disconnect Switch, and a Thermal Disconnect if and as required by local code.

NOTICE Wiring must be provided by the Electrician; it is not supplied with the Lift.

⚠ DANGER All electrical work must be performed by a licensed Electrician. Verify all electrical work conforms to all applicable local and federal codes, rules and regulations, such as state and federal OSHA regulations and electrical codes.

⚠ DANGER A licensed Electrician must perform all wiring. Do not perform any maintenance until main electrical power has been disconnected from the Lift and cannot be re-energized until all procedures are complete.

Electrician's Tasks

Your Electrician needs to:

- Connect the Power Unit to an electrical power source. An electric power source is required. The Power Unit comes with a Pigtail for wiring to a power source. Have your Electrician connect a power cord with appropriate plug to the electrical box on the Lift (for connection to a power outlet) or have them wire it directly into the electrical system at the Lift location.

NOTICE

Note that installing the Power Unit and connecting the Power Unit to the power source are separate procedures and are done at different times in the installation process. You do not need an Electrician to install the Power Unit, but an Electrician *is required* to connect the Power Unit to the power source.

- Install a Power Disconnect Switch. Ensures you can quickly and completely interrupt electrical power to the Lift in the event of an electrical circuit fault, emergency situation, or when equipment is undergoing service or maintenance. Put it within sight and reach of the Lift operator.
- Install a Thermal Disconnect Switch. Ensures the equipment shuts down in the event of an overload or an overheated motor. The Power Unit supplied with this Lift does not include thermal overload protection. Under NEC 430, UL 201, and CSA C22.2 No. 68 intermittent duty motors are not required to include thermal protection. Local electrical codes may vary, and other requirements may exist that the installing electrician will address, if required.

NOTICE

These components are not supplied with the Lift.

⚠ DANGER

All wiring must be performed by a licensed Electrician.

Important electrical information:

- Improper electrical installation can damage the Power Unit motor, which is not covered by the warranty.
- The Lift uses electrical energy; if your organization has Lockout/Tagout policies, make sure to implement them after connecting to a power source.
- Use a separate circuit breaker for each Power Unit.
- Protect each circuit with a time delay fuse or circuit breaker:
- For a 208 to 240 VAC, single phase circuit, use a 20 amp fuse.
- A power cord and appropriate 220 VAC plug for connecting to an appropriate power source or the items required to connect to the facility's power system.
- A Power Disconnect Switch.
- A Thermal Disconnect Switch, if required by local codes.

Additional information is supplied in the sections describing these tasks.

Connecting the Power Unit

The Power Unit must be connected to an appropriate power source.

⚠ DANGER A licensed Electrician must install all wiring in accordance with local and national electrical codes. Do not perform any maintenance or installation on the Lift without first making sure that main electrical power has been disconnected from the Lift and cannot be re-energized until all procedures are complete. The Lift uses electrical energy; if your organization has Lockout/Tagout policies, make sure to implement them after connecting to a power source.

To prepare the Power Unit for normal operation:

- Mount the Power Unit to the Power Side Post. Described in **Mounting the Power Unit**.
- Attach the Hydraulic Line to the correct location on the Power Unit. Described in **Routing Hydraulic Lines**.
- Fill the Hydraulic Fluid reservoir. Covered in this section.

Power Units

Your 9APF & 12APF Lift is available with a Power Unit meeting the specifications listed below: other voltages *maybe* available upon request.

- **208-240 VAC, 50/60 Hz, 1 Phase.**

110 VAC Power Units are **not** available for 9APF Lifts *at the time of writing*.

Specialized 3 Phase, Low RPM Power Units may also be available on request.

Some Power Units are provided by different suppliers so there may be minor differences in look and feel. Nevertheless, all Power Units of the same general type provide the same functionality.

All Power Units are delivered with a 'pigtail' exiting the electrical junction box. To install your Power Unit, remove the pigtail and connect the Electrical Box to the electrical system at your location or to an appropriate power cord with plug.

The illustration at the right is a view of a typical Power Unit; the power unit delivered *may look different* depending on what was purchased.

Note: The Up Button shown in this illustration could be in a different location on the unit or could be a switch instead of a button, depending on the Power Unit you have.

Make clear to your Electrician that all electrical work **must** conform to applicable local, state, and federal codes, rules, and regulations.

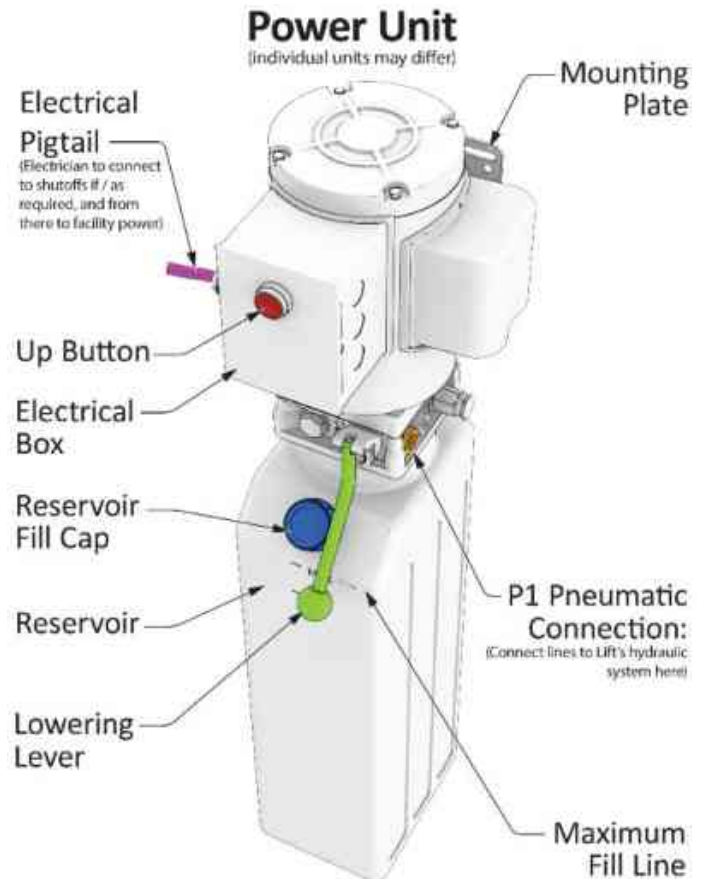

To prepare the Power Unit:

1. Have the Electrician locate the Pigtail exiting the Electrical Box on the Power Unit.
2. Open the Electrical Box, remove the Pigtail, and then either:
 - Wire the Power Unit directly into the facility's electrical system.
 - Wire a power cord (with appropriate plug) *inside the Electrical Box* to the wiring that was connected to the Pigtail.

Wiring information is either on the outside of the Power Unit under the Electrical Box or inside the cover of the Electrical Box. Have the Electrician use that wiring information to wire the Power Unit to the power source.

⚠ DANGER Always refer to the lubricant and hydraulic fluid manufacturer's Material Safety Data Sheet (MSDS) for information on the proper handling and disposal of chemicals.

3. Fill the Hydraulic Fluid reservoir with approved Hydraulic Fluid.

The reservoir holds \approx 3.7 gallons (14 L) of Hydraulic Fluid, depending on Power Unit ordered.

When you receive the Power Unit, the reservoir is empty; fill it to the Maximum Fill Line.

Approved Hydraulic Fluids are any general-purpose ISO-32, ISO-46, or ISO-68 hydraulic oil; approved Automatic Transmission Fluids such as Dexron VI, Mercon V, Mercon LV, or any synthetic multi-vehicle Automatic Transmission Fluids should be used *only* in situations where the unit is subjected to *sustained* temperatures below 41° F, to prevent premature hydraulic seal wear.

⚠ WARNING Do *not* run the Power Unit without Hydraulic Fluid; you will damage it.

Important electrical information:

- Improper electrical installation can damage the Power Unit motor; this damage is **not** covered by the warranty.
- Use a separate circuit breaker for each Power Unit.
- Protect each circuit with a time-delay fuse or circuit breaker appropriate for the Power Unit in use.
 - 208-240 VAC single phase circuit.
- The Electrician must connect the Power Disconnect Switch and the Thermal Disconnect Switch if required by local codes.

⚠ DANGER **Risk of explosion:** The Power Unit has internal components that may spark and should not be exposed to flammable vapors. This device is not intrinsically safe. Internal Arcing may ignite combustible gases. The power unit motor must be mounted at least 18 in. above the ground.

⚠ DANGER **Never expose** the Power Unit motor to rain or other damp environments. Damage to the motor caused by water is **not** covered by the warranty.

Installing a Power Disconnect Switch

⚠ WARNING A Power Disconnect Switch is not provided with this equipment.

A Power Disconnect Switch is a National Electrical Code (NEC) requirement. They are designed to interrupt main electrical power in the event of an electrical circuit fault, emergency, or when equipment is undergoing service or maintenance.

Make sure to install a Power Disconnect Switch that is properly rated for the incoming power source.

Your Power Disconnect Switch must be readily accessible and installed so that it is in easy reach of the operator or in their line of sight. The Power Disconnect Switch must be clearly marked to indicate its purpose.

The figure to the right shows a Power Disconnect Switch located between the Lift's power source and its Power Unit. A quick flip of the switch immediately cuts power to the Lift.

In the case of this Lift, the location chosen for the Power Disconnect Switch must completely avoid any fastener interference with Lift Head or slide blocks.

⚠ DANGER Installing a Disconnect Switch **must** be accomplished by a licensed, Electrician.

Have the Electrician select a **UL-listed** Power Disconnect Switch.

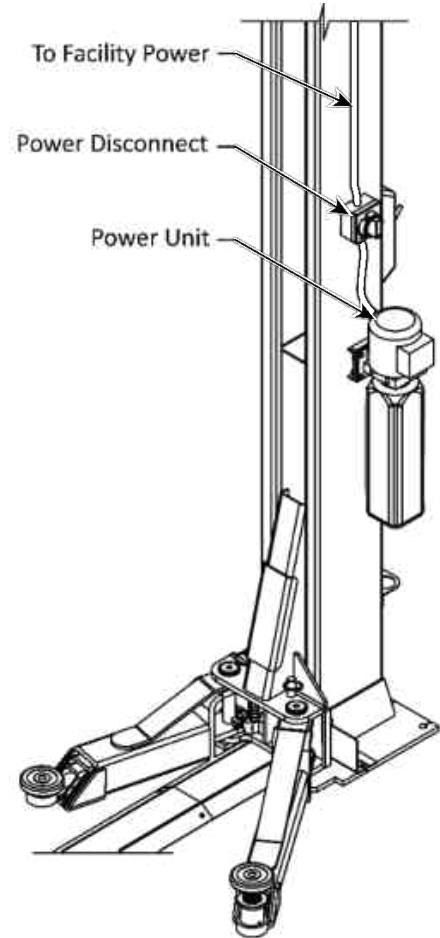

Installing a Thermal Disconnect Switch

⚠ WARNING This Lift motor has **no** thermal overload protection.

The Power Unit supplied with this Lift **does not** include thermal overload protection. Under NEC 430, UL 201, and CSA C22.2 No. 68 intermittent duty motors are not required to include thermal protection. Local electrical codes may vary, and other requirements may exist that the installing electrician will address, if required.

⚠ DANGER If local Electrical codes require the installation of a Thermal Disconnect, the disconnecting device and the installation **must** be provided by a licensed Electrician in accordance with local electrical codes. Do not perform **any** maintenance or installation on the Lift without first verifying that main electrical power has been disconnected from the Lift and **cannot** be re-energized until all procedures are complete.

BendPak strongly recommends that you do **not** exceed the rated duty cycle of the Lift motor.

Leveling

Before operating your Lift, verify the Lift Posts are perpendicular to the ground and the Lift Arms are level:

- **Lift Posts:** The Posts **must** be the same distance apart at the top and at the bottom.

To make sure the Posts are straight, measure the distance between the posts at one foot off the ground (First move the Lift Arms out of the way) and near the top of the posts. The two measurements (**A** and **B** in the drawing below) must be the same.

If the Posts are not straight, shim them as required.

CAUTION If the Lift Posts are not straight upright or the Lift Arms are not level, this is a safety risk. The Vehicles placed on the Lift will be less secure; they could fall and cause injuries or damage to the Vehicle or to the Lift.

- **Lift Arms:** When the Lift Posts are straight, verify the Lift Arms are level. To make sure they are level, raise them to the first locking position and put a level on the Pads.

Adjust the Equalizing Cables to correct any out of level condition. Determine which Lift Arm is low, then adjust the Nut on the bottom of the Threaded End of the Equalizing Cable until the Lift Arms are level. When the Lift Arms are shown to be level, raise the Lift and listen for the Lift Heads hitting the Safety Locks (there is a distinct thump). Engagement sounds should be simultaneous.

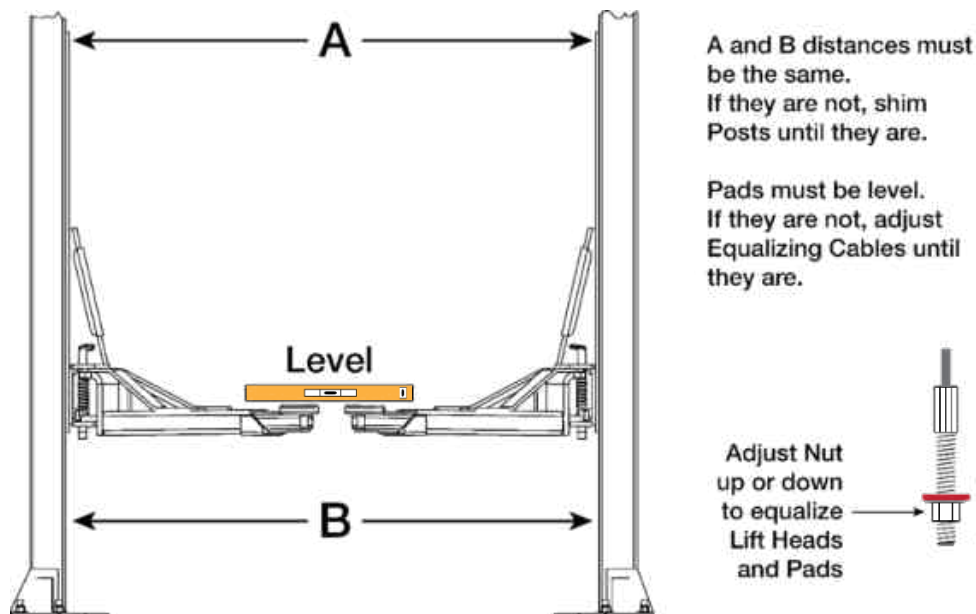

Installing the Safety Covers

There are two Safety Covers, one for each Safety Assembly, on the outside of each Post.

Refer to [Installing the Safety Assemblies and the Safety Lock Cable](#) for more information about installing the Safety Assemblies.

The Safety Covers are interchangeable:

- The Offside Safety Cover can only be installed in one orientation.
- The Power Side Safety Cover can only be installed in one orientation: there is a slot on the front bottom face for the Safety Lock Release Handle.

Both Safety Covers connect to their Posts via M6 Button Head Socket Cap Hex-head Screws in the upper left and right corners.

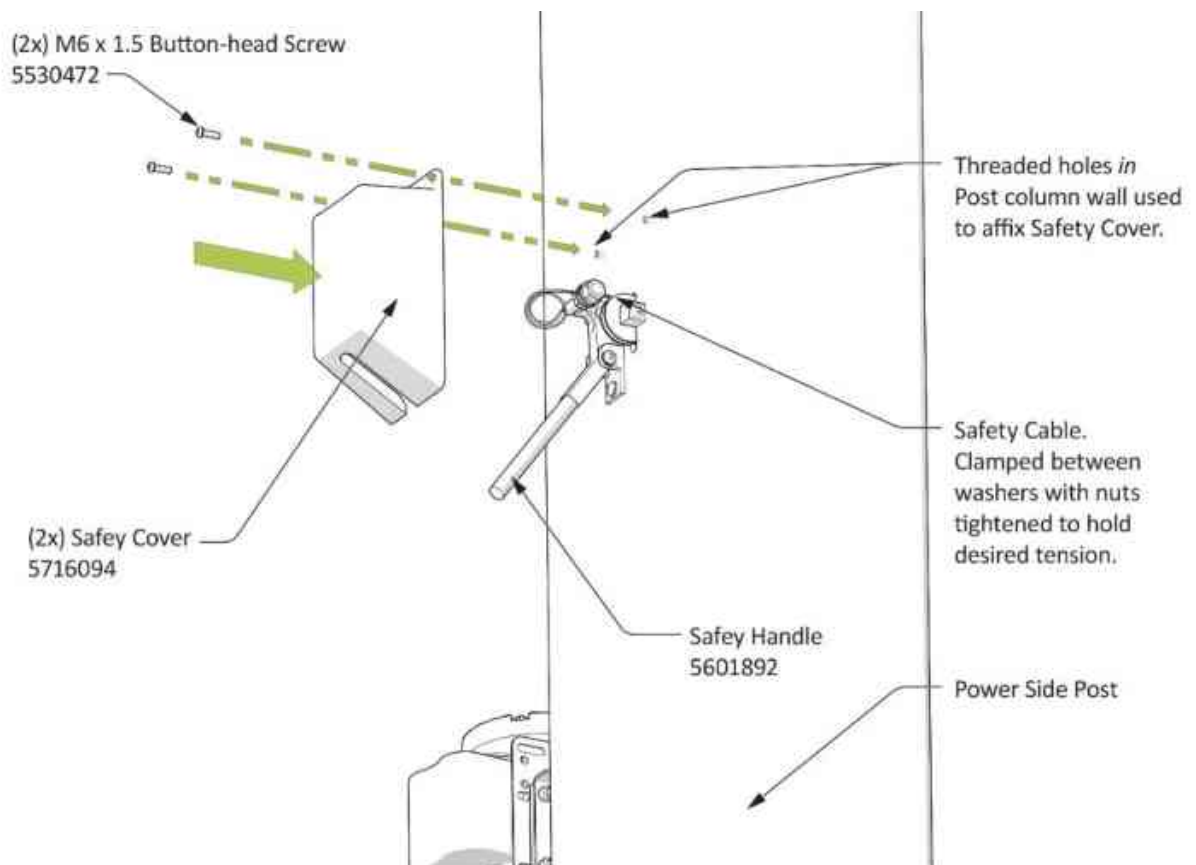

To install the 9APF Safety Covers:

1. Locate the two Safety Covers and four Cover Screws.
2. **On the Off Side Post**, install the Cover Screws through the Safety Cover and into the relevant hole in the Post, making sure to engage the threaded hole in the post's wall to hold the Safety Cover securely; do not overtighten, as the Safety Cover is plastic.
3. **On the Power Side Post**, install the Cover Screws through the Safety Cover and into the relevant hole in the Post, making sure to engage the threaded hole in the post's wall to hold the Safety Cover securely; do not overtighten, as the Safety Cover is plastic.
4. Fully tighten both sets of Cover Screws into their threaded holes so that the Safety Cover is held securely, but do not overtighten, as the Safety Cover is plastic.

Install the Floor Plate 9APF Only

The Floor Plate protects the Hydraulic Hoses, their connections, the Equalizing and Safety Cables. The **9APF** uses two long Floorplates (562092 and 562095) for the **narrow configuration**. The Floor Plate is mechanically captured between the Lift Post Base Plates, and is fastened with anchors for security.

The **9APF** in the **wide configuration** requires an extension (562094) and four fasteners (5530480) as detailed in the figure below.

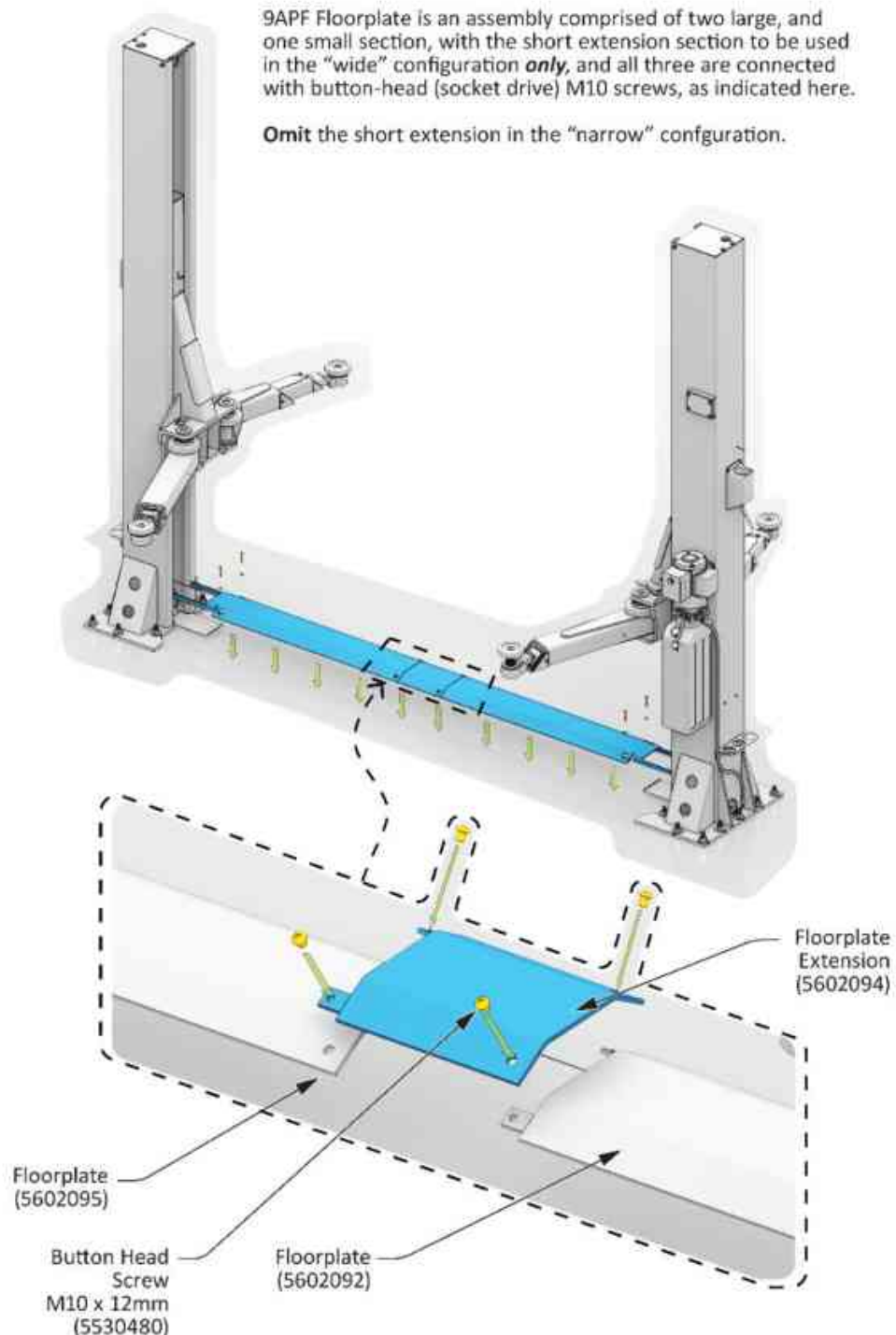

Install the Floorplate 12APF Only

The Floorplate protects the Hydraulic Hoses, their connections, the Equalizing and Safety Cables. The **12APF** uses two long Floorplates (5602114 and 5602117) which are connected at the center. The Floorplate is mechanically captured between the Lift Post Base Plates, and is fastened with anchors for security.

The floorplates should be put in place as detailed in the next illustration.

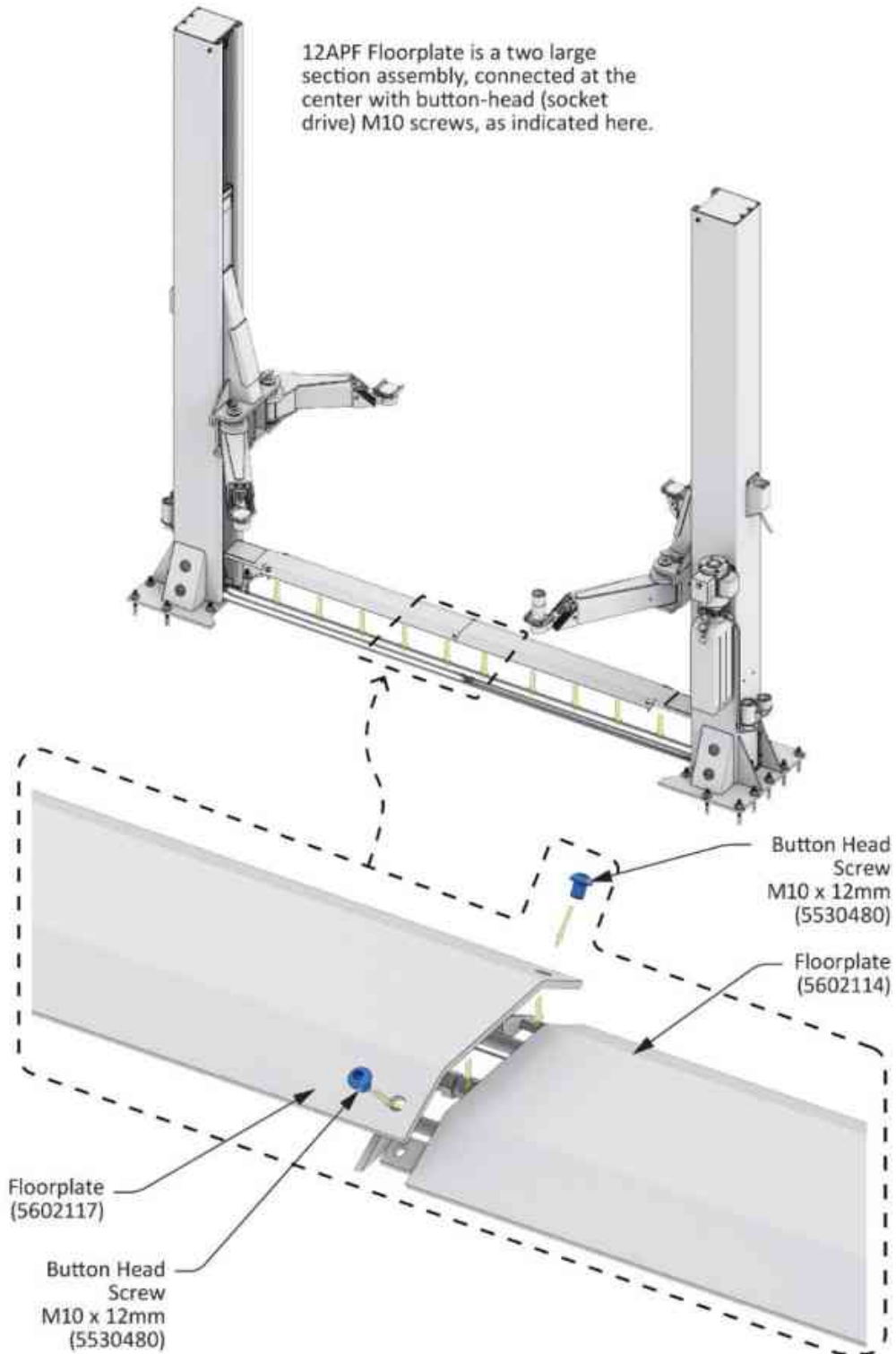

Perform an Operational Test

Before putting the Lift into normal operation, we recommend raising and lowering it several times with a typical Vehicle on it. This will help you get a feel for how to operate the controls and help get any residual air out of the Hydraulic System (sometimes called “bleeding” the system).

 **DANGER** Automotive Lifts are dangerous tools when used by inexperienced or impaired technicians. When you even hear the words “automotive lift,” your brain should automatically register the fact that lifting a vehicle is a serious endeavor with life-threatening risks if mandatory lifting precautions are ignored.

During the Operational Test, check for proper installation and operation. Do not raise any additional Vehicles until a thorough Operational Test has been done with a typical Vehicle.

 **WARNING** **Never raise a Vehicle whose weight exceeds the rated capacity of the Lift.** Do not leave the controls until the Lift is engaged on its Safety Locks. Only trained personnel should raise or lower the Lift.

To perform an Operational Test:

1. Follow the instructions in **Raising a Vehicle** and **Lowering a Vehicle** to safely raise and lower a Vehicle on the Lift.

 **WARNING** Be sure to follow the instructions carefully when it comes to contacting the manufacturer’s recommended Lifting Points on the underside of the Vehicle. If you do not, the Vehicle could become unstable and fall, which could damage the Vehicle, damage the Lift, and injure or even kill anyone under the Vehicle.

2. Adjust the Lift Arms under the Vehicle so the Adapters are **directly under** the Lifting Points for the Vehicle you are raising.

3. Raise the Lift until **just before** the Adapters contact the Lifting Points.

4. Check the Arm Restraint Gears on all four Lift Arms to make sure they are engaged.
If they are not engaged, move the Lift Arms back and forth until they engage.

5. Raise the Lift until the tires of the Vehicle are a few inches off the ground.

6. Check to verify all four Adapters are making solid contact with the Lifting Points.

If any of the Adapters are **not** making solid contact with the Lifting Points, carefully lower the Lift, and start over again; the Adapters **must** make solid contact with the Lifting Points.

7. Raise the Vehicle approximately three feet (one meter) off the ground, then lower it back down.

Watch and listen as the Lift raises and then lowers. The Lift may move erratically or make some odd noises the first couple of times you use it; this is normal.



Tip

Residual air in the Hydraulic System can cause the Lift to shake, move erratically, or squeak; this is normal when you first start using the Lift. It will soon stop doing this, as the Hydraulic System is self-bleeding.

8. Wait for one minute.

NOTICE The Power Unit is **not** a constant duty motor; **it cannot be run continuously.**

9. Repeat the process, this time raising the Lift, engaging it on a Safety Lock position, taking it off the Safety Lock position by raising it, and then lowering it back down to the ground.

Follow the instructions in **Raising a Vehicle** and **Lowering a Vehicle** to safely raise and lower a Vehicle on the Lift, including engaging it on its Safety Locks.

10. If the Lift is working without shaking, moving erratically, or squeaking, there is no need to repeat the procedure.

If the Lift is shaking, moving erratically, or squeaking, repeat the procedure one more time.

If you continue to have issues, refer to **Troubleshooting** for assistance.

11. When the Lift is on the ground and the Vehicle is on all four tires, move the four Lift Arms to their full drive-through positions.

12. Drive the Vehicle out.

Review Final Checklist Before Operation

Make sure these things have been done before putting the Lift into normal operation:

- Review the **Installation Checklist** to make sure all steps have been performed.
- Verify the Power Unit is getting power from the power source.
- Check the Hydraulic Fluid reservoir; it must be full of approved Hydraulic Fluid or automatic transmission fluid. **You can harm the motor by running it without enough fluid.**
- Check the Hydraulic System for leaks. Verify all Hydraulic Hose connections, Hydraulic Fittings, and Auxiliary Port Plugs on the Lift and Power Unit are tight.
- Verify both Posts are plumb, shimmed, and stable.
- Check to see that all Anchor Bolts are correctly torqued.
- Apply white lithium grease to the inside of the Posts where the Slide Blocks move.
- Make sure both Threaded Rods are in place and tightened near the top of both Posts.
- Verify all Cables are properly positioned in their Sheaves.
- Verify all Cable Sheave retaining pins and/or clips are secure.
- 12APF Only: Verify the Cylinder Clamp is present and secured above the top of the Lift Head on both hydraulic cylinders.
- Make sure both Safety Assemblies are connected and working normally.
- Make sure that all Safety Locks are clear and free.
- Make sure an Operational Test has been done.
- Leave the *Installation and Operation Manual* with the owner/operator.



Operation

This section describes how to operate the **9APF** and **12APF** Two-Post Lifts.

 **DANGER** Automotive Lifts are dangerous tools when used by inexperienced or impaired technicians. When you even hear the words “automotive lift,” your brain should automatically register the fact that lifting a vehicle is a serious endeavor with life-threatening risks if mandatory lifting precautions are ignored.

Lift Operation Safety Rules

Important: Your safety is dependent on reading, understanding, and implementing these Safety Rules. **Do not skip over them; read them carefully and follow them!**

Do the following before you raise or lower a Vehicle on your Lift:

- **Check the Lift.** Check the Lift for any missing, heavily worn, or damaged parts. Do not operate the Lift if you find any issues; instead, take it out of service, contact your dealer, email support@bendpak.com, or call **(800) 253-2363**, then follow the prompts.
- **Check the area.** Keep the area around the Lift clean and free of obstructions; anything that could cause a problem for the Lift. Do not forget to check **above** the Lift. If you find an obstruction, move it out of the way. Do not allow any people or animals within 30 ft. (9.144 m) of the Lift while it is in motion.
- **Check the operators.** Make sure that everyone who is going to operate the Lift has been trained in its use, has read the labels on the unit, and has read the manual. Only the operator should be within 30 ft. (9.144 m) of the Lift when it is in motion. Do not allow children to operate the Lift. Do not allow anyone under the influence of drugs or alcohol to operate the Lift.
- **Check for safety.** Make sure everyone who is going to be walking near the Lift is aware of its presence and takes appropriate safety measures. Only put Vehicles on the Lift Arms. **When raising a Vehicle on the Lift, do not leave it until it is positioned on Safety Locks.** When lowering the Lift, do not leave it until it is on the ground.
- **Check the Vehicle.** Never exceed the Lift’s weight rating. Do not allow people inside a Vehicle you are going to raise. Make sure the Vehicle is not overbalanced on either end. Make sure you know the manufacturer’s recommended Lifting Points for the Vehicle. Never raise just one side, one corner, or one end of a Vehicle.

 **WARNING** Always use care when you are around your Lift. When it is in a lowered position, be careful not to trip over it. When it is raised, be careful not to strike your head on the Lift Arms or the Vehicle. **When you are raising or lowering a Vehicle, keep all people, animals, and objects at least 30 ft. (9.144 m) away from the Lift.**

About Lifting Points, Adapters, and Auxiliary Adapters

An important concern when using a frame-engaging Lift is that the raised Vehicle must be balanced on the four Lift Arms. If the Vehicle is not balanced, it is more likely to become unstable and slide off the Lift, possibly damaging the Lift, the Vehicle, and anything under the Lift, including injuring people.

⚠ WARNING You **must** use all four Lift Arms when raising a Vehicle. Never use just one, two, or three Lift Arms to raise a Vehicle. The Vehicle will be unstable and could slip off the Lift, possibly damaging the Lift, damaging the Vehicle, and injuring anyone under it.

To balance a Vehicle on a frame-engaging Lift, you need to have the Adapters (also called Pads) contact the Vehicle on the manufacturer's recommended Lifting Points. When you raise a Vehicle by its Lifting Points, the Vehicle is balanced.

NOTICE The manufacturer's recommended Lifting Points do not take into consideration any major changes that might have been made to the Vehicle. If the motor is removed, for instance, or there is a 5,000 lbs. (2,268 kg) weight in the trunk, the Vehicle's Lifting Points will not be the best balancing points.

Some Vehicles have indicators on the underside that identify the Lifting Points; many do not.

Your best approach is to find the Vehicle in the **ALI guide**, *Vehicle Lifting Points for Frame Engaging Lifts* or contact the manufacturer of the Vehicle. This guide also includes a page of safe lifting suggestions, which everyone who uses this Lift should read.

Lifting it Right: A Safety Manual from the Automotive Lift Institute, also available through **ALI**, includes a wide variety of information about Lifts and how to use them safely.

⚠ DANGER **Never** place Contact Pads under non-approved, non-load holding Sill Covers or Side Skirts!



Standard Accessories

The **9APF** is supplied with **Four Screw Lift Pad Assemblies** (5216239) best suited for vehicles with unibody construction; they are height adjustable, up to 2.165 in (55 mm).

The **12APF** is supplied with **Frame Cradle Pads** (5215702), as well as Long and Medium Adapters (5215759 & 5215758).

Refer to the parts box drawing for each unit for a complete listing; note that parts numbers provided here are for kits of four. Individual units have separate part numbers.

Optional Accessories

Visit bendpak.com for additional Adapters and Auxiliary Adapters (also called height adapters or extenders) available adapters include the following:

- **Four Medium Auxiliary Adapters - 2.25 in. (56 mm)** (5746192). Allows you to position the height of your Auxiliary Adapters to make better contact with Vehicles.
- **Four Long Auxiliary Adapters - 2.5 in. (63 mm)** (5746193). Allows you to position the height of your Auxiliary Adapters to make better contact with Vehicles.

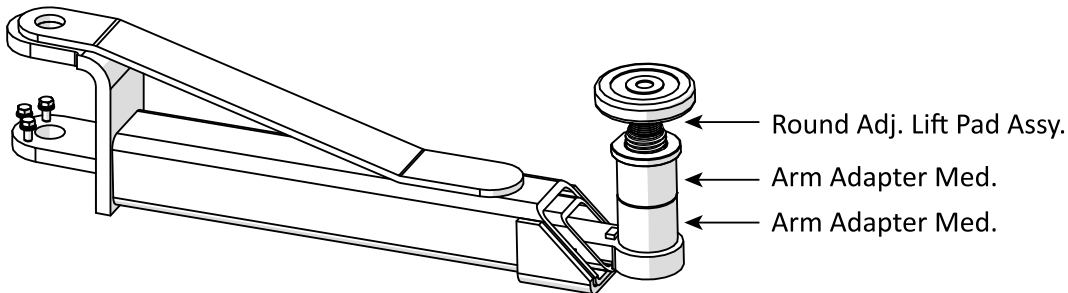

⚠ WARNING You can stack the optional Auxiliary Adapters, but only up to 9 in. (229mm). If you stack Auxiliary Adapters above 9 in. the Vehicle could become unstable and slip off the Lift, possibly damaging the Lift, damaging the Vehicle, and injuring anyone under it.

⚠ WARNING Use the correct Adapters. Do not attempt to lift trucks or other frame type vehicles with standard Rubber Contact Pads.

⚠ WARNING Never use the Lift with missing or damaged rubber Contact Pads. Always replace Rubber Contact Pads when worn or damaged.

- **Quick-Fit Slotted Pinch-Weld Pucks or Pads** — Always use slotted Pinch-Weld Pucks (5210263) or slotted Pinch-Weld Pads (5210254) when lifting Vehicles on Manufacturer Approved Pinch-Weld Jacking Points. These convenient tear-resistant urethane Adapters simply fit over the existing round Contact Pads.

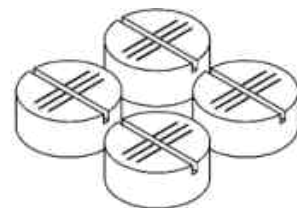
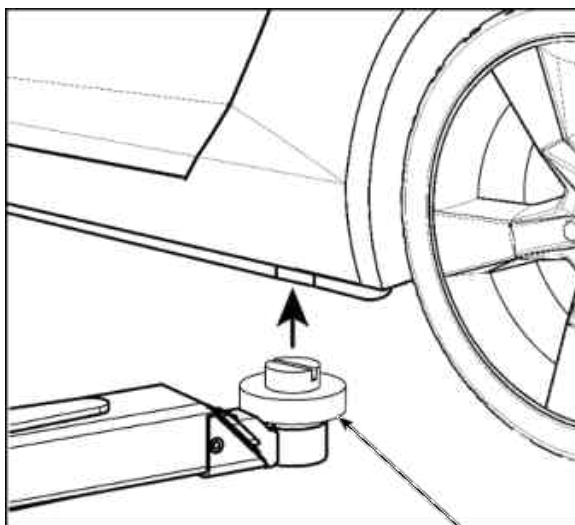

5210254 Set of 4 Slotted Pads

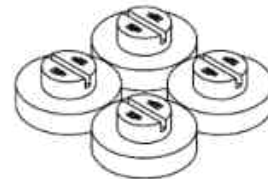

5210263 Set of 4 Slotted Pucks

✓ Always use slotted Pads or Pucks when lifting Vehicles on OEM-approved Pinch Weld Jacking Points.

- **Frame Cradle Adapters** — Required for use when lifting trucks, vans or other frame Vehicles that require additional stability. (5215761) Set of 4.

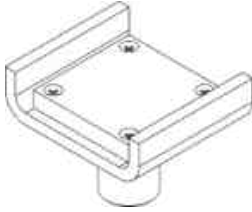

- **Wide Frame and Super Wide Frame Cradle Adapters** — Recommended for use when lifting heavy-duty wide frame vehicles. **Wide Frame** version fits frames up to 5.25 in. (133 mm) (5215848). **Super Wide Frame** version fits frames up to 6.5 in. (168 mm) (5210253) set of 2.

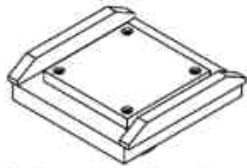

Wide Frame Cradle Adapter

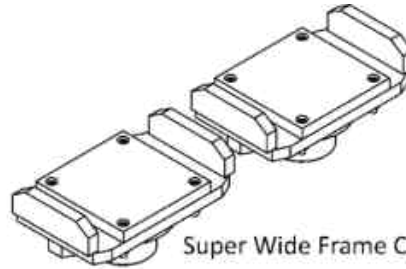

Super Wide Frame Cradle Adapter

- **Steel Lift Pads** — Recommended for additional stability on all vehicles. The flanged edges grip the chassis for an extra-secure hold. (5215763) Set of 4.

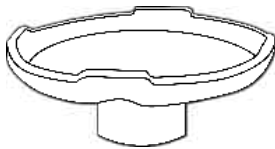

- **Replacement Polyurethane Tuf Pads™** - Never use your Lift with missing or damaged Rubber Contact Pads. Always replace Pads when worn or damaged, (5715052) individual Pads.



- **SUV and Van Adapters** — Recommended for Trucks, SUVs, and Vans the require additional lifting height.

56 mm Set of 4 (5215757)

63 mm Set of 4 (5215758)

125 mm Set of 4 (5215759)

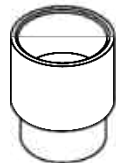

56 mm

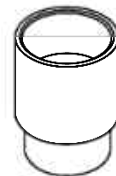

63 mm

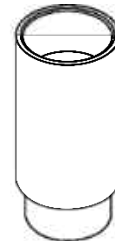

125 mm

Visit BendPak.com for accessories and replacement Parts information at **(800) 253-2363** then follow the prompts. Please have the model and serial number of your Lift available.

Raising a Vehicle

This section describes how to raise a Vehicle on your Lift.

- ⚠ WARNING** Never raise a Vehicle whose weight exceeds the rated capacity of the Lift. Do not leave the controls until the Lift is engaged on a Safety Lock position or fully lowered. Only trained personnel should raise and lower the Lift.

To raise a Vehicle on the Lift:

1. Make sure all four Lift Arms are on the ground in their full drive-through positions.
2. Check under the Vehicle you are going to raise, check for the type of vehicle frame, and then put the most appropriate Adapters on the Lift Arms.

If you are lifting a sedan or a Vehicle with a unibody construction, a Screw Lift Pad is generally the best choice. If you are lifting an SUV, truck, or other Vehicle with a frame construction, a Frame Cradle Pad is generally the best choice.

- ⚠ WARNING** Always use the Adapter type best suited for the Vehicle you are raising. If you use the wrong Adapter type, the Vehicle could become unstable.

3. Drive the Vehicle in.

- ⚠ CAUTION** When driving a Vehicle into position, keep to the middle of the area between the Posts. If you hit a Lift Arm or any other portion of the Lift, you could damage the Vehicle and/or the Lift.

4. When you are satisfied with the location of the Vehicle, put it in park, put on the parking brake, and turn off the motor.

If the Vehicle is a manual transmission, put it into first gear before turning off the motor.

5. Get out of the Vehicle; open the doors carefully to avoid banging them on the Lift.
6. Locate the manufacturer's recommended Lifting Points for the Vehicle you are raising.

If you are unsure where the Lifting Points are, consult Vehicle Lifting Points for Frame Engaging Lifts, which is available through ALI at www.autolift.org/ali-store/, or the manufacturer of the Vehicle.

Some vehicles may have the manufacturers' recommended Service Garage Lift Point locations identified by a triangle mark on the underside of the vehicle, reference SAE J2184- (Current Edition). On some vehicles, specific Lifting Points are indicated by a label located on the driver's side door jamb.

- ⚠ DANGER** Do not 'eyeball' the best location for the Adapters. **You must use the manufacturer's recommended Lifting Points.** If you do not, the Vehicle could become unstable and fall, which could damage the Vehicle, damage the Lift, or injure or even kill anyone under the Vehicle.

- ⚠ WARNING** Many specialty or modified Vehicles, or Vehicles with *unusually short or long wheelbases* cannot be safely on raised on a Two-Post Frame Engaging Lift. Contact the Vehicle's manufacturer for Lifting or Jacking guidance.

The following figure illustrates typical lifting points based on Vehicle Frame type.

Typical Lifting Points

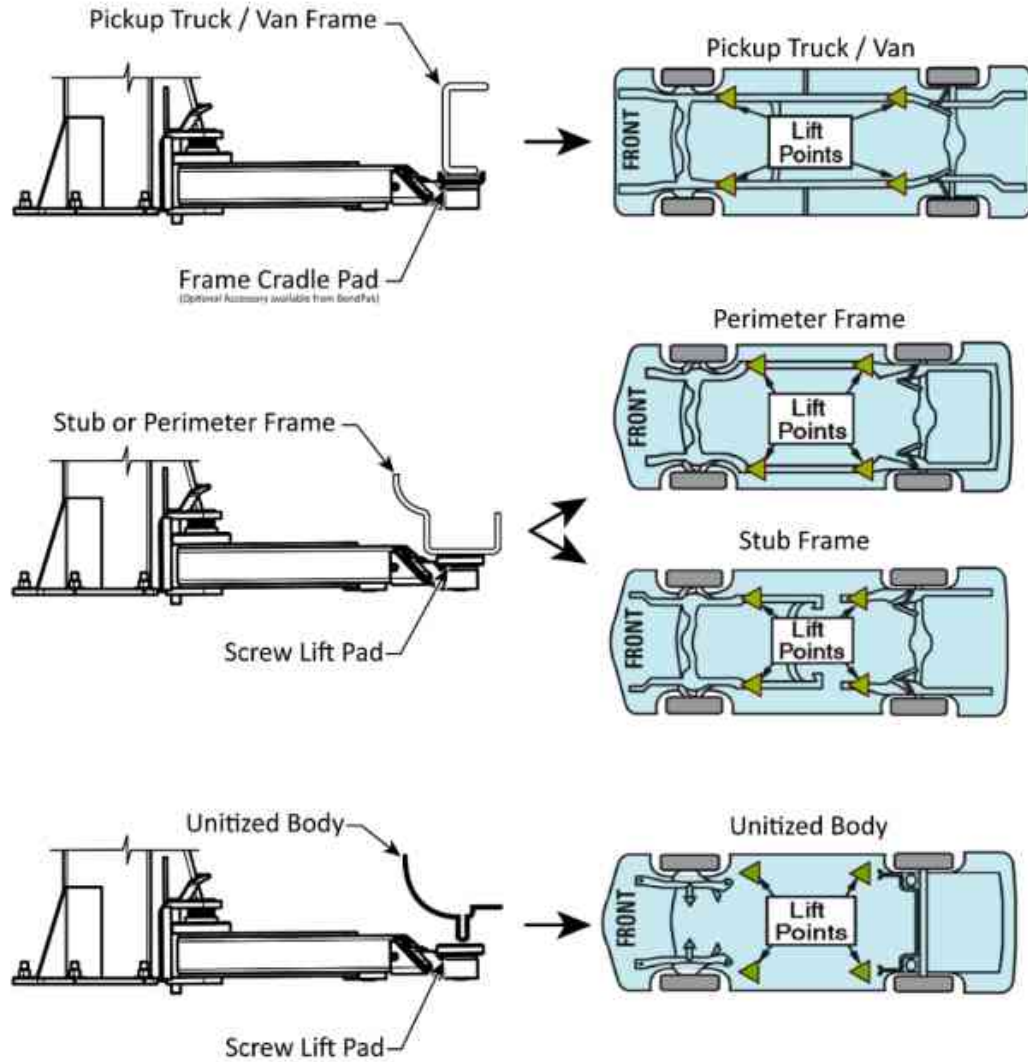

⚠ WARNING Before attempting to lift a Vehicle verify:

- The Vehicle Frame is strong enough to support its weight and has not been weakened or compromised by modification, damage, or corrosion.
- The Vehicle's individual axle weight does not exceed one-half the Lift capacity.
- The Lift Adapters are in secure contact with the Frame at the Vehicle manufacturers' recommended Lift Points.
- The Vehicle is stable on the Lift and the center of gravity is not shifted, making the Vehicle off balance.

7. Adjust the Lift Arms under the Vehicle so the Adapters are **directly under** the Lifting Points for the Vehicle you are raising.

If necessary, use optional Auxiliary Adapters for extra height.

8. Raise the Lift until **just before** the Adapters contact the Lifting Points.

9. Check the Arm Restraint Gears on all four Lift Arms to make sure they are engaged.

If they are not engaged, move the Lift Arms back and forth until they engage.

-
10. Raise the Lift until the tires of the Vehicle are a few inches off the ground.
 11. Check to make sure all four Adapters are making solid contact with the Lifting Points.
If any of the Adapters are **not** making solid contact with the Lifting Points, carefully lower the Lift, and start over again; the Adapters **must** make solid contact with the Lifting Points.
 12. Rock the Vehicle to verify it is stable and balanced.
If the Vehicle is **not** stable and balanced, lower the Lift back to the ground and start over.
If the Vehicle **is** stable and balanced, you can raise it to the desired height.

 **DANGER** Do not raise the Lift further until you are certain the Vehicle on the Lift is both stable and balanced. If the Vehicle is **not** stable and balanced, it could fall, which could damage the Vehicle, damage the Lift, or injure or kill anyone under the Vehicle.

13. Press and hold the **Up** Button.
Listen as the Lift passes the Safety Locks; you should hear each side pass by the Safety Locks at approximately the same time.
14. When the Vehicle reaches the desired height, go past the next Safety Lock position (you will hear the clank as it passes), then release the **Up** Button.
15. Press and hold the Lowering Handle, which lowers the Lift onto the Safety Lock you just passed.
Do not hold the Safety Lock Release Handle; that is for lowering the Lift to the ground.
16. When the Lift stops moving down, it is engaged on its Safety Locks; release the Lowering Handle.
Do not leave the Lift controls unless the Lift is engaged on its Safety Locks or fully lowered.
17. Recheck the Adapters to verify they are all still making solid contact with the Lifting Points.
18. Make sure the Lift is engaged on the same Safety Lock on both Posts. You do not want the Lift engaged on Safety Locks of two different heights or one Safety Lock engaged but the other not.
19. Begin work on the Vehicle.

 **DANGER** Only leave the Lift fully lowered or engaged on a Safety Lock. Never move or work under a vehicle unless it is stable and resting on a Safety Lock.

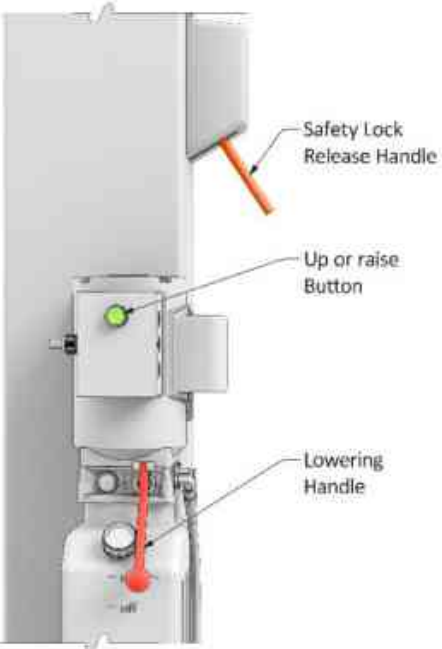
<p>To raise Lift:</p> <ol style="list-style-type: none"> 1. Press and hold Up Button. 2. When Lift is just past desired height, release Up Button. 3. Press and hold Lowering Handle. <p><i>Do not pull down the Safety Lock Release Handle. If you do, the Lift will continue to lower and will not engage on its Safety Locks.</i></p> <p>Lift engages on its Safety Locks and stops moving; release Lowering Handle when Lift stops.</p> <p><i>Only leave Lift on Safety Locks or fully lowered.</i></p>		<p>To lower Lift:</p> <ol style="list-style-type: none"> 1. Press and hold Up Button for two to three seconds. This moves Lift off its Safety Locks. 2. Pull down and hold Safety Lock Release Handle and Lowering Handle. Lift begins lowering. 3. When Lift is fully lowered, release Safety Lock Release Handle and Lowering Handle. <p><i>Only leave Lift on Safety Locks or fully lowered.</i></p>
-----------------------------------------------------------------------------------------------------------------------------------------------------------------------------------------------------------------------------------------------------------------------------------------------------------------------------------------------------------------------------------------------------------------------------------------------------------------------------------------------------------------------------------------------------	------------------------------------------------------------------------------------	----------------------------------------------------------------------------------------------------------------------------------------------------------------------------------------------------------------------------------------------------------------------------------------------------------------------------------------------------------------------------------------------------------------------------------------------------------------

Lowering a Vehicle

To lower a Vehicle off the Lift, first raise it a small amount to move it off its Safety Locks, then hold in the Safety Lock Release Handle and the Lowering Valve on the Power Unit at the same time to lower the vehicle.

To lower a Vehicle off the Lift:

1. Check under and around the Vehicle to verify the area is clear of all obstructions.
If you find any obstructions, move them out of the way.
2. Press and hold the **Up** Button for a second or two to move the Lift off its Safety Locks.
Raise the Lift at least 2 in. (51 mm) to move clear of the Safety Locks.
3. Push in and hold the Safety Lock Release Handle (on the Power Side Post above and to the right of the Power Unit).
4. Push and hold the Lowering Valve Handle (on the front of the Power Unit). The Lift begins lowering.

Important: Both the Safety Lock Release Handle **and** the Lowering Valve Handle must be held in simultaneously to lower the Lift.

⚠ DANGER Do not override the Lift controls; for safety purposes, they are designed to stop the Lift if released. Overriding the Lift controls *could* lead to damage to the Lift, damage to the Vehicle on the Lift, or injury (even death) to persons near the Lift.

Remain clear of the Lift as it lowers; obey the pinch point warning decals.

5. When the Lift is on the ground, release both Handles, then move all four Lift Arms to their full drive-through positions.
6. Drive the Vehicle out when the way is clear.

About Safety Locks

Your Lift has multiple Safety Lock positions, allowing you to lock the Lift at the best height for what you need to do.

A Safety Lock **position** is defined as when the Lift is engaged on both of the Lift's Safety Locks at the same height on both Posts.

Important: Always make sure the Safety Locks are engaged at the same height on both Posts. You do not want the Lift engaged on Safety Locks of two different heights or the Safety Lock on one Post engaged but the Safety Lock on the other Post not engaged.

Safety Lock positions are created by the Safety Lock Blocks, which are on the back of each Lift Head. Safety Stop Blocks hit the Safety Locks and then move past them as the Lift Heads rise.

Safety Lock Function

(some components omitted or ghosted for clarity)

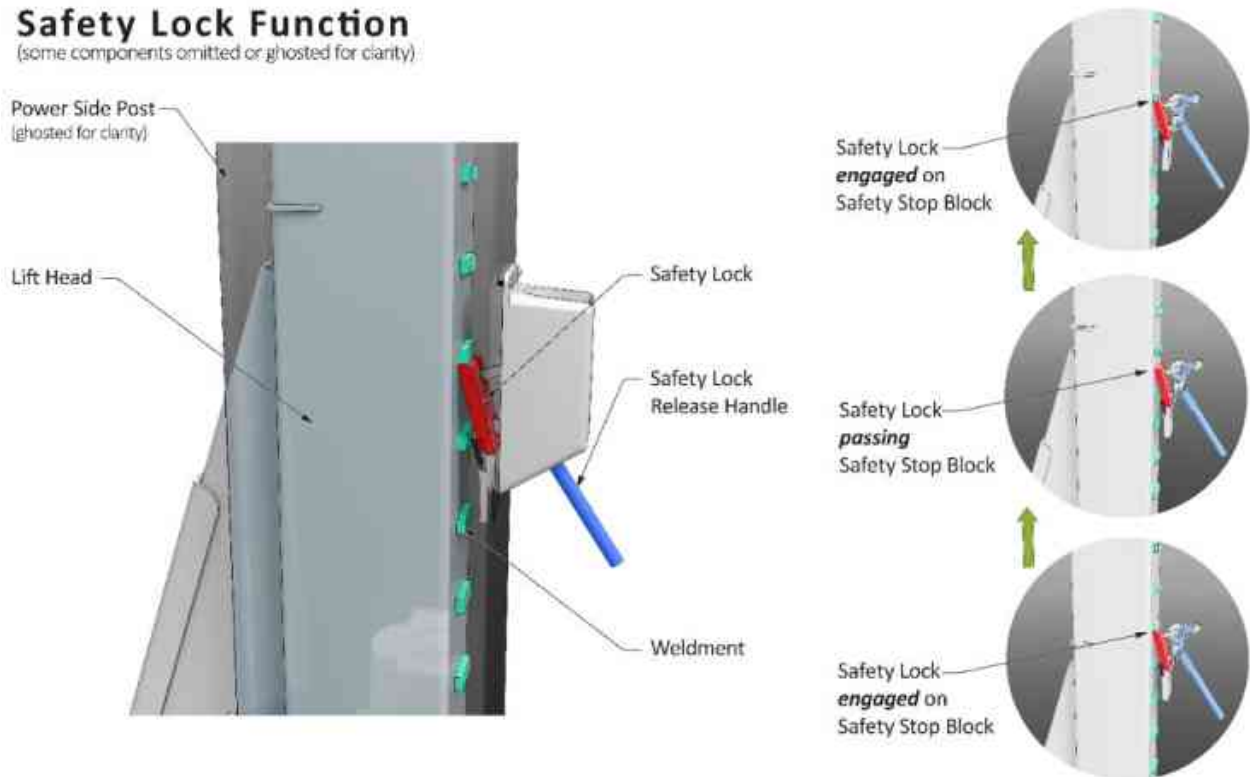

Drawing not to scale. Components removed for clarity. Offside Safety Lock not shown.

As they move past the Safety Locks, the Safety Stop Blocks push the Safety Lock and the Safety Lock Release Handle down (the Safety Lock Release Handle is found on the Power Side Post only). When the Block is completely past the Safety Locks, the Safety Locks spring back into position between Blocks. This happens each time Safety Locks are passed, so you will generally be hearing multiple clanks as the Lift rises and the Safety Locks return to position.

To engage the Lift on a Safety Lock position, wait until the Vehicle reaches the desired height for the work you are going to do, then listen for the clank as the Safety Stop Blocks pass the next Safety Lock position. When you hear the Safety Lock clank, release the Up Button, and then hold down the Lowering Valve Handle (on the front of the Power Unit) for a second or two to back the Safety Stop Blocks down onto the just-passed Safety Locks; *do not* hold down the Safety Lock Release Handle.

⚠ WARNING Only leave the Lift either fully lowered or engaged on Safety Locks. **If you leave the Lift raised but not engaged on Safety Locks, the Vehicle is not secure.** It could fall, possibly damaging the Vehicle, the Lift, and injuring anyone under the Vehicle.

Maintenance

⚠ DANGER Before performing any maintenance on your Lift, make sure it is completely disconnected from power. The Lift uses electrical energy; if your organization has Lockout/Tagout policies, make sure to implement them before performing any maintenance. If you come into contact with high voltage/current, you could be injured or killed.

⚠ DANGER Do not use the Lift if the cables are damaged or extremely worn. If a Vehicle is raised when you notice the damage or extreme wear, very carefully lower the Vehicle to the ground. When the Lift is on the ground, remove it from service, disconnect it from power, and make arrangements to have it repaired.

⚠ WARNING Do not operate your Lift if you find maintenance issues; instead, remove it from service and correct the maintenance issues. Technical support and service is available from your dealer, on the Web at bendpak.com/support, by email at support@bendpak.com, or by phone at **(800) 253-2363**, then follow the prompts.

Online chat is also available at www.bendpak.com click the chat icon.



Read the Installation and Operation manual and understand how this equipment operates before using, maintaining, or repairing. Routine maintenance and adjustments are the responsibility of the owner/user and are not covered under warranty.

Routine maintenance and adjustments should be carried out on a regular basis as outlined below. *Unless stated otherwise, all maintenance may be performed by the owner/employer and does not require trained lift service personnel.* Replace worn, damaged or broken parts with original BendPak or BendPak approved parts or with parts that meet or exceed the original specifications.

Maintenance and Lubrication Interval Recommendations:

This lift's service life is dependent on the level and frequency of care and maintenance you provide. By simply following a few guidelines, you can increase the life of your lift by many years. The following care and maintenance procedures not only help to foster that, but also aid by ensuring safe operation and early detection of problems.

Tools required:

- Open End Wrench Set
- Hydraulic Fluid (same type as currently listed; Monthly Maintenance)
- Shop Towels
- Screwdrivers
- Hex Key Set

Lubricants:

- White Lithium Multi-Purpose Lubricant
- Red Lithium Grease
- ALMASOL Wire Rope Lubricant or 90W Gear Oil

The following maintenance and interval recommendations are based on typical workday use and operation.

Daily Maintenance

1. Keep the Lift and work area clean, to promote safety and better problem visibility.
2. Visually inspect that the Safety Locks are in good operating condition. Do not use your Lift if the Safety Locks are damaged or excessively worn.

⚠ WARNING Always wear proper Personal Protective Equipment when working with hydraulics. Gloves and Safety Glasses are a minimum requirement. Keep your body away from suspected leaks. Use a clean piece of sheet metal (or new paper towel) to rub along hoses and fittings to detect leaks. Shut down the equipment if a leak is suspected.

3. Watch for hydraulic fluid leaks on hoses and hose fittings. Inspect for damage. Hose covers that are cut, cracked, blistered, show signs of abrasion, kinking or flattened are to be replaced.
4. Verify the cylinder clamp is in place and tight on the hydraulic cylinder above the Lift head.

Monthly Maintenance and Maintenance

1. Remove, clean, and apply new Red Lithium grease to all Cable Sheave Pins as outlined in the **Lubrication Procedure** on the following page.
2. Inspect the condition of all Equalizing Cables and mechanisms. Run a shop towel over the Cable surface while watching for snags. Replace as required.
3. Inspect all hydraulic hoses and fittings for damage and leaks. Approved Hydraulic Fluids are any general-purpose ISO-32, ISO-46, or ISO-68 hydraulic oil.
4. Apply 90-WT gear oil or ALMASOL® Wire Rope Lubricant to both Equalizing Cables.
5. Apply White Spray Lithium MP grease to the four inside contact corners of both Posts.
6. Apply White Spray Lithium MP grease to all Lift Arm Pivot Points.
7. Apply Red Lithium grease to all Sheave Pins.
8. Inspect all Lift Arm Pins and locking mechanisms for damage and wear. Replace as required.
9. Verify all fasteners are torqued to specifications.
10. Verify all Warning labels are in good condition and legible.

Every Two Months

Verify all anchor bolts are secure and torque to 85-95 ft.-lbs.

Every three to five years or sooner as required

1. Carefully check the Equalizing Cables for signs of damage or extreme wear. See **Wire Rope Inspection and Maintenance** for additional information.
2. If the Lift becomes inoperative in a raised position, see the **Troubleshooting** section.

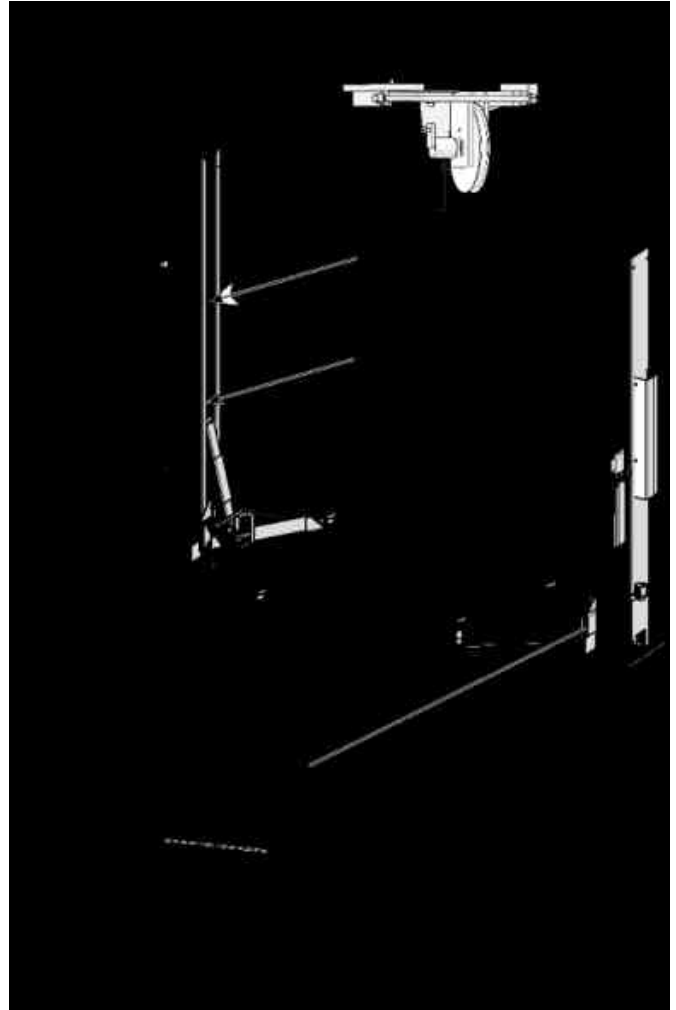

Lubrication Procedure

⚠ DANGER Always refer to the lubricant and hydraulic fluid manufacturer's Material Safety Data Sheet (MSDS) for information on the proper handling and disposal of chemicals.

To Lubricate

1. Raise the Lift Head (if required) to rest on at least the first Safety Lock.
2. Remove the Polyethylene Cover from the Lift Head then loosen the Cable Nut to relax the cable.
3. Lubricate the Sheaves.
 - a. Remove the hairpin securing the pin at the sheave.
 - b. Remove the Pin from the Sheave.
 - c. Apply Red Lithium Grease to the Pin.
 - d. Reinstall the Sheave Pin through the Sheave then re-insert the hairpin.
 - e. Tighten the Cable Nut. See Leveling Section to readjust Lift Arms.
4. Lube 4 inside lift head vertical contact tracks (inside posts) with white lithium grease.
5. Lube cables with ALMASOL or 90W gear oil.

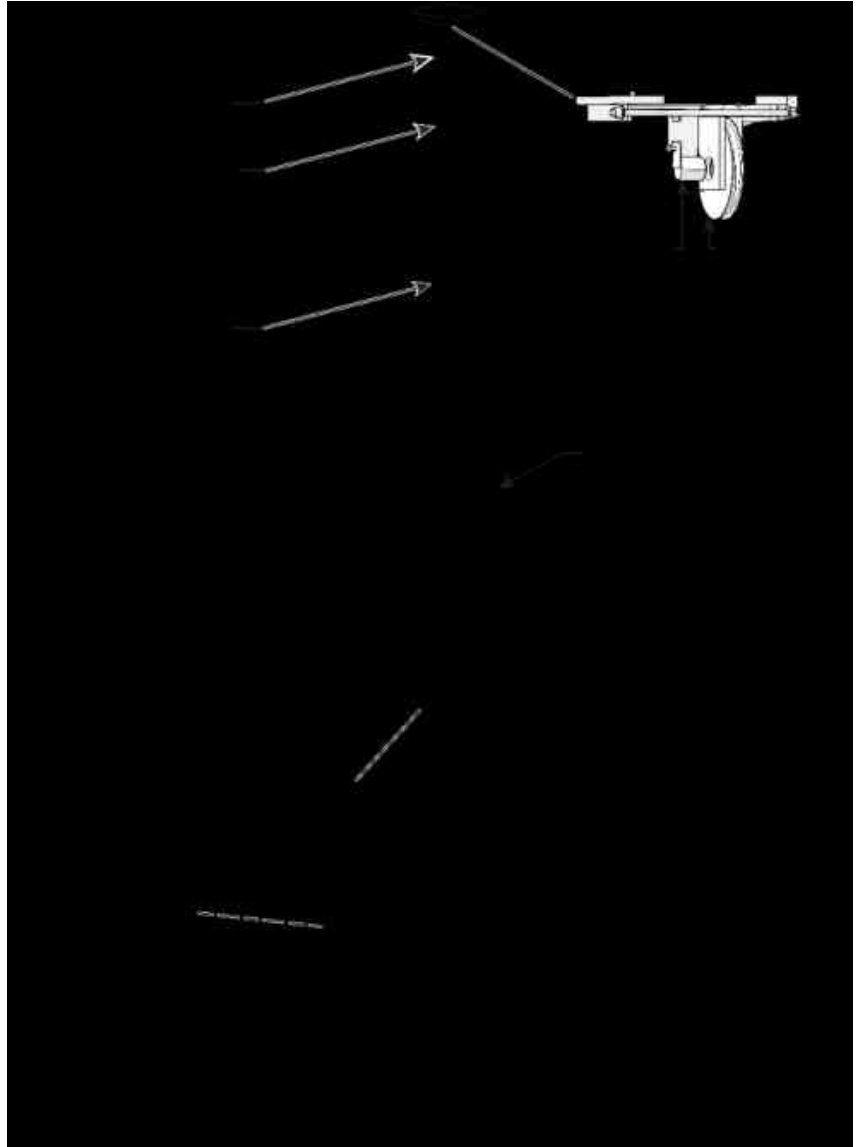

9APF and 12APF Wire Rope Inspection and Maintenance

The 9APF and 12APF wire ropes should be inspected regularly:

- Equalizing cables should be replaced when there are visible signs of damage or extreme wear. **Do not use the Lift if it has damaged or worn cables.**
- Lifting cables should always be maintained in a well-lubricated condition.

Wire rope is fully protected when each wire strand is lubricated both internally and externally. Excessive wear shortens the life of wire rope. Use a wire-rope lubricant that penetrates to the core of the rope and provides long-term lubrication between each individual strand, such as 90-WT gear oil or ALMASOL® Wire Rope Lubricant.

To make sure that the inner layers of the rope remain well lubricated, lubrication should be carried out at intervals not exceeding three months during operation.

- All sheaves and guide rollers in contact with the moving rope should be given regular visual checks for surface wear and lubricated to make sure they run freely. This operation should be carried out at appropriate intervals generally not exceeding three months during operation.

For all sheave axles, use Red Lithium grease. For all sheaves guide rollers (sheave cable-groove), use 90-WT gear oil or a similar heavy lubricant, applied by any method including pump/spray dispensing, brush, hand, or swabbing.

- How often should the Cables be inspected?

Lifting cables should be visually inspected at least once each day when in use, as suggested by American Petroleum Institute's Recommended Practice 54 guidelines. Any lifting cables that have met the criteria for removal must be immediately replaced.

- When should you replace lifting cables due to broken wires?

Lifting cables should be removed from service when you see six randomly distributed broken wires within any one lay length, or three broken wires in one strand within one lay length.

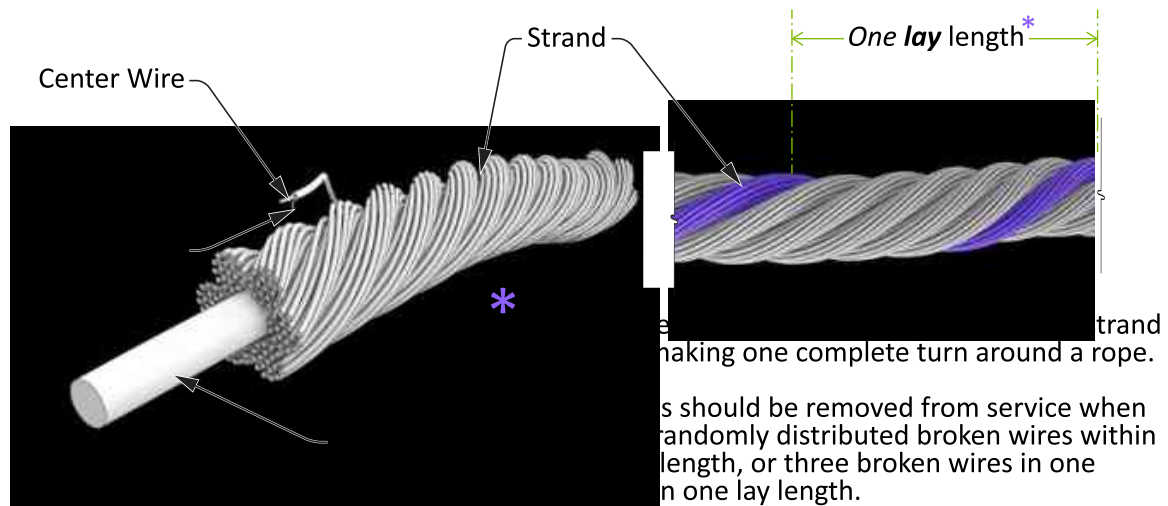

- Are there other reasons to replace your lifting cables?

Yes. Corrosion that pits the wires and/or connectors, evidence of kinking, crushing, cutting, birdcaging, or a popped core, wear that exceeds 10% of a wire's original diameter, or heat damage.

Wire Rope Issues

(Stop use *immediately* and order replacements if you see *any* of these)



Corroded & Pitted

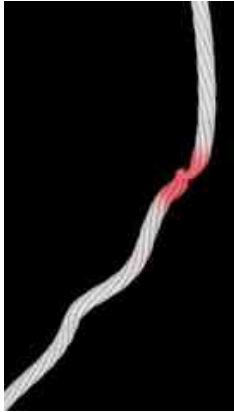

Kinked



Crushed







Cut / Frayed

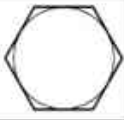

Birdcaging

- How do you find broken wires?
 - a. Relax your rope to a stationary position and move the pick-up points off the sheaves. Clean the surface of the rope with a cloth — a wire brush, if necessary — so you can see any breaks.
 - b. Flex the rope to expose any broken wires hidden in the valleys between the strands.
 - c. Visually check for any broken wires. One way to check for crown breaks is to run a cloth along the rope to check for possible snags.
 - d. With an awl, probe between wires and strands and lift any wires that appear loose. Evidence of internal broken wires may require a more extensive rope examination.

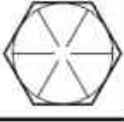
Torque Chart

FASTENER TORQUE CHART												
Bolt Grade (SAE)		SAE Grade 0-1-2		SAE Grade 5		SAE Grade 8		Socket Head Cap Screw	SAE Grade			
Bolt Class (Metric)												
Bolt Size (SAE)	Tightening Torque			Tightening Torque			Tightening Torque					
	Lubricated (ft.-lbs)	Zinc Plated (ft.-lbs)	Plain & Dry (ft.-lbs)	Lubricated (ft.-lbs)	Zinc Plated (ft.-lbs)	Plain & Dry (ft.-lbs)	Lubricated (ft.-lbs)	Zinc Plated (ft.-lbs)	Plain & Dry (ft.-lbs)			
1/4-20	2.3	2.6	3.0	5.8	6.6	7.7	8.3	9.4	11.1	9.7	11.0	13.0
5/16-18	3.8	4.3	5.0	9.7	11.0	13.0	13.9	15.8	18.5	16.3	18.4	21.7
3/8-16	10.8	12.3	14.4	27.9	31.6	37.2	39.9	45.2	53.2	46.7	52.9	62.2
7/16-14	24.0	27	30.0	35.0	42	50.0	55.0	59	70.0	61.0	68	76.0
1/2-13	18.9	21.4	25.2	48.7	55.1	64.9	69.6	78.9	92.8	81.4	92.2	108.5
9/16-12	30.2	34.2	40.2	77.8	88.1	103.7	111.3	126.1	148.4	130.0	147.4	173.4
5/8-11	47	53	62	121	137	161	173	196	230	202	229	269
3/4-10	65	73	86	167	189	222	239	270	318	279	316	372
7/8-9	136	155	182	320	365	430	460	515	600	510	575	640

WARNING! Prior to installation, inspect all accompanying manuals, parts lists and catalogs to ensure you have all the necessary parts. Identify all fasteners and their proper torque settings as illustrated on this chart. Proper torquing practices cannot be over emphasized. Torque values are provided as a convenient method of achieving correct pre-loading of highly stressed fasteners. If the fasteners are not properly plated, the fastener threads are not clean and free of deformation, or are not properly lubricated, the correct fastener pre-load will not be achieved even though the given torque value is reached. For this reason, it is critical that all fasteners be inspected for proper plating, thread form and correctly lubricated prior to torquing. Failure to verify a fastener's serviceability or to correctly lubricate the fastener prior to assembly and torquing will result in the fastener not being properly pre-loaded and subsequent failure of the fastener may occur. The torque values can only be achieved if the nut (or tapped hole) has a proof load greater than or equal to the bolt's minimum ultimate tensile strength. Clamp loads estimated as 75% of proof load for specified bolts. Torque values are listed in foot-pounds. Torque wrenches should be calibrated on an annual basis. Never use an impact driver on a torque multiplier.

Troubleshooting

This section describes how to troubleshoot your Lift.

⚠ CAUTION If your Lift is not functioning correctly, you must take it out of service until it is fixed.
Qualified personnel must perform all repair work.

⚠ WARNING The Lift uses electrical energy; if your organization has Lockout/Tagout policies, make sure to implement them before performing any Troubleshooting.

Issue	Action to Take
Once raised, Lift does not lower.	Verify there is sufficient Hydraulic Fluid in the reservoir. Make sure there is no air in the Hydraulic System. Make sure none of the Hydraulic Hoses are pinched or leaking. Make sure the Power Unit is getting electrical power. If the Hydraulic Fluid is dirty, replace it with clean fluid. Make sure the Lift is not overloaded. Make sure the load on the Lift is balanced. Contact BendPak Support at bendpak.com/support , via email at support@bendpak.com , or by phone at (800) 253-2363 select option 7, then 4.
Lift Head and Arms move erratically or squeak when in use.	Move the Lift Head up and down a few times to flush any residual air from the Hydraulic System.
Lift does not stay up.	Make sure to leave the Lift engaged on its Safety Locks. Check for Hydraulic Fluid leaks.
Vehicle on Lift not level.	Make sure Lift is engaged on Safety Locks at the same height. Make sure the Safety Locks in both Posts are engaged. If either condition is not met, carefully lower the Vehicle back down to the ground and raise it again.
Motor not running.	Check connection to power source; make sure it is plugged in and the appropriate voltage. Check wiring diagram on Power Unit.
Hydraulic Fluid is dirty.	Refill with approved Hydraulic Fluid: any general-purpose ISO-32, ISO-46, or ISO-68 hydraulic oil.
Lift makes odd noises.	Lubricate hinge points using white lithium grease.

If you continue to have issues with your Lift, take the Lift out of service, then contact your dealer or BendPak Support at bendpak.com/support, via email at support@bendpak.com, or by phone at **(800) 253-2363** then follow the prompts.

Troubleshooting Lift Arm Lock Disengagement

⚠ WARNING Avoid excessive Shim heights! A new concrete cutout and steel reinforced pour are recommended to correct out of level conditions in excess of 3°.

Some floors with excessive out of level conditions may require Shim heights that reach or exceed .5 in. / 12.7 mm. When the Shim Height reaches this level, the Lift Arm Lock Pins may not function to disengage the Lift Arms when completely lowered. To correct this condition, the Arm Lock Pins include an M12 x 1.75 internal thread, approximately 12 mm deep. A mating M12 Hex Head Bolt with Lock Washers, or a backing nut (not supplied) may be used to extend the contact point of the Arm Lock Pins. Adjust the Bolt head position to disengage the Lock as required. Refer to the figure below.

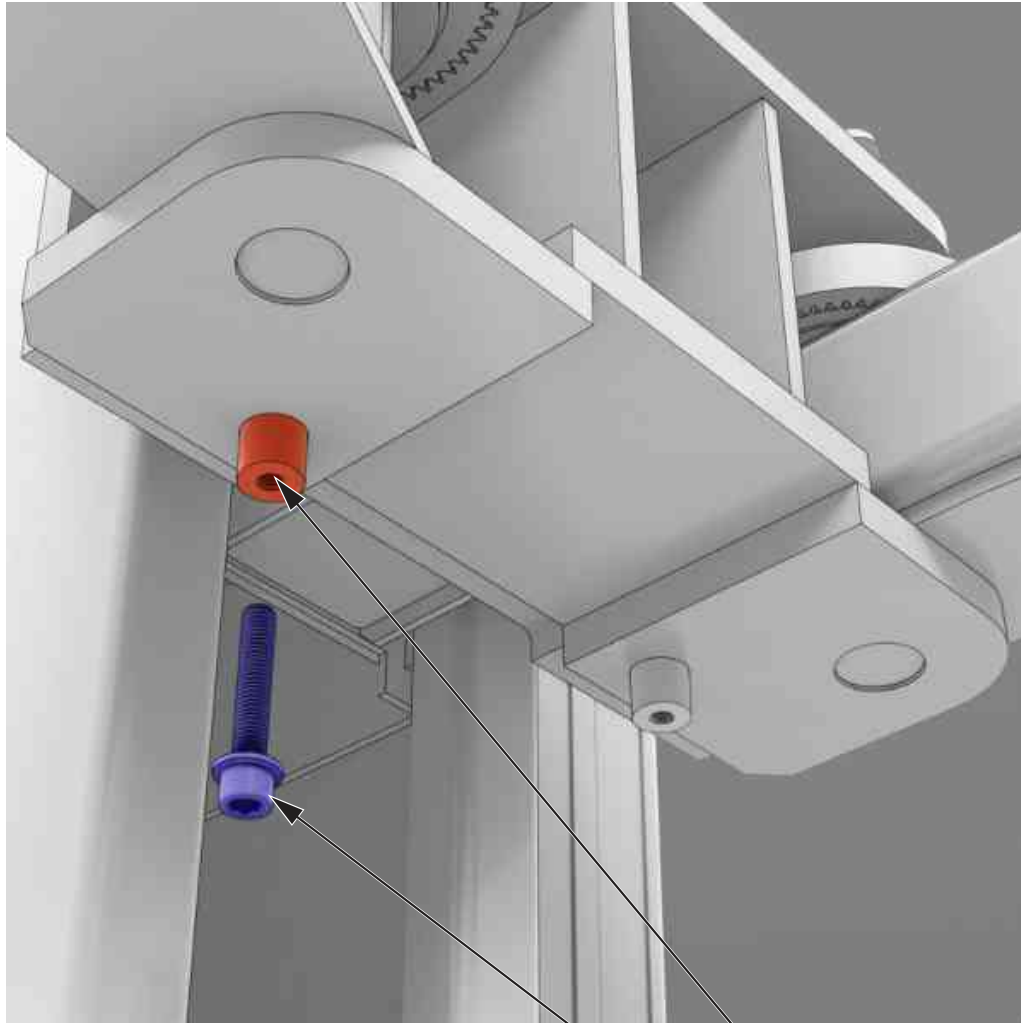

When Arm Lock Pins do not both make proper contact with the floor, a work-around to get arm release can be used: these pins include an M12 x 1.75 internal thread, approximately 12 mm deep.

A mating M12 Hex Head Bolt with Lock Washers, or a backing nut (not supplied) may be used to extend the contact point of the Arm Lock Pins.

Lift Arm Lock Pin
M12 x 1.75

M12 x 1.75 Bolt(s)
and Lock Washers
not supplied

Disposing of Used Hydraulic Fluid

Used Hydraulic Fluid **must not** be disposed of by dropping it into the trash or dumping it into the street. It has toxic ingredients that are harmful to the environment.

Instead, you are required to either recycle it or drop it off at a hazardous waste collection facility.

If you are unable to find an appropriate facility, the website earth911.com has resources that may be of help.

 **DANGER** Always refer to the lubricant and hydraulic fluid manufacturer's Material Safety Data Sheet (MSDS) for proper handling and disposal of chemicals.

9APF & 12APF Lift Disposal - End of Service Life

Once your Lift has reached the end of its service life it must be disposed of properly. Metal recyclers will be able to advise on methods and costs to remove the Lift and will *reuse* the materials, diverting them from landfills. The best option is to contact a metal recycling center and discuss the size and weight of the Lift to determine if the facility can deconstruct and recover the usable components and metals.

The Hydraulic Cylinders, Hoses, Fittings, and the Power Unit itself must be disposed of in accordance with current national, state, and local regulations governing the use and disposal of hazardous materials. These components and any used Hydraulic Fluid **must not** be disposed of by dropping it into the trash or dumping it into the street. The Hydraulic Fluid contains toxic ingredients that are harmful to the environment.

These components and the Hydraulic Fluid are required to be recycled or must be delivered to a hazardous waste collection facility.

If you have large amounts of Hydraulic Fluid, consider contacting a commercial waste disposal company. In all cases, the best approach is to find an appropriate facility and contact them — in advance — to ask them: what kinds of fluids and materials they accept, what kind of containers it must be in, what hours they are open, their location, and any other information specific to their facility.

If you are unable to find an appropriate facility, the website earth911.com has resources that may be of help.

Wiring Diagram

5585454 208-240VAC Single Phase
50/60Hz, 4HP, ≈14Amps

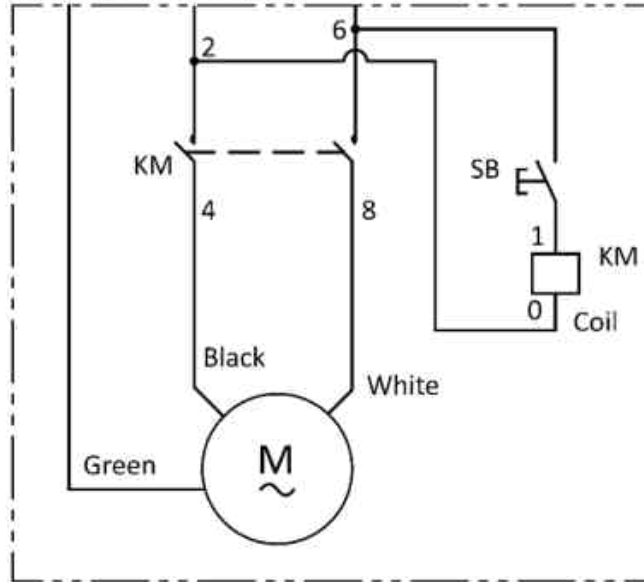

5585685 208-230VAC, 23A, Single Phase
50/60 Hz, 5HP

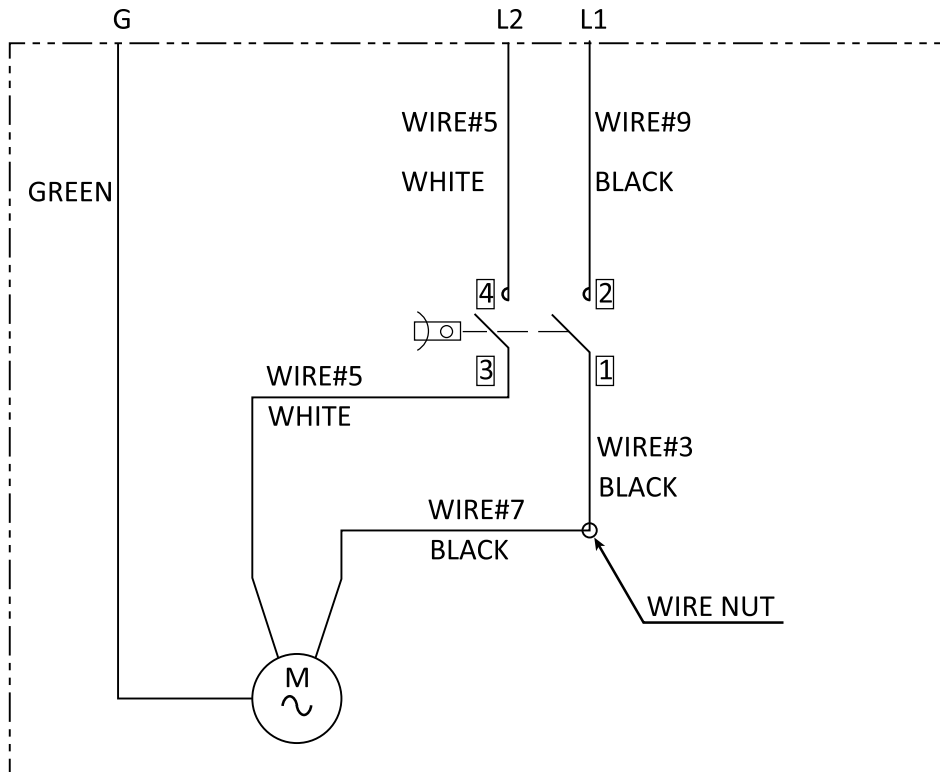

Labels



PN 5906112
BPK_Made_Strong_Post
_Branding_Decal
 Size: 4.25"W x 37.5"H

A **IMPORTANT**
NECESSAIRE POUR L'UTILISATION CORRECTE DE CE LÉVATEUR À HAUTE CAPACITÉ
NECESSARY TO THE PROPER USE OF THIS LIFT

A DANGER

A DANGER

A CAUTION **A MISE EN GARDE**

A WARNING **A ATTENTION**

LES ENGELS PERMETTENT **LES ENGELS PERMETTENT**

NECESSARY TO THE PROPER USE OF THIS LIFT **NECESSARY TO THE PROPER USE OF THIS LIFT**

A WARNING **A ATTENTION**

LES ENGELS PERMETTENT **LES ENGELS PERMETTENT**

NECESSARY TO THE PROPER USE OF THIS LIFT **NECESSARY TO THE PROPER USE OF THIS LIFT**

A WARNING **A ATTENTION**

LES ENGELS PERMETTENT **LES ENGELS PERMETTENT**

NECESSARY TO THE PROPER USE OF THIS LIFT **NECESSARY TO THE PROPER USE OF THIS LIFT**

LIFT OPERATION **OPÉRATION DE LEVAGE**

PN 5906087
2-Post_Safety_&Lift
Operation_Decal-FRE-ENG
-5906087-REV
 Size: 8.5"W x 44"H

C **BP BendPak** 30440 Apurva Road
 Apurva Hills, CA USA
 www.BendPak.com

LIFT TYPE: Surface Mount **MANUFACTURER:** BendPak. See data plate for product details.

POWER: Electric/Hydraulic **INSTALLATION:** See manual or contact factory

Safety Instructions: If attachments, accessories, or configuration-modifying components that are located in the load path affect operation of the lift, affect the lift electrical rating, or affect intended vehicle accommodation are used on this lift and, if they are not certified for use on this lift, then the certification of this lift shall become null and void. Contact the participant for information pertaining to certified attachments, accessories, or configuration-modifying components.

BendPak lifts are supplied with concrete fasteners meeting the criteria as prescribed by ASTM E488/E488M-18. Lift buyers are responsible for any special regional, structural, and/or seismic anchoring requirements specified by any other agencies and/or codes such as the Uniform Building Code (UBC) and/or International Building Code (IBC).

The manufacture, use, sale, or import of this product may be subject to one or more United States patents, or pending applications, owned by BendPak Inc.

Do Not Remove Engineered by BendPak Inc., USA PN 5905940 Made in China

PN 5905940
Product_Data_Label_5905940_REV_02-24
 Size: 4.5"W x 2.75"H

D₉ **A DANGER**

THE MAXIMUM LIFTING CAPACITY FOR THIS LIFT IS DESCRIBED BELOW

Maximum Lifting Capacity
 9,000 lbs. / 4,082 kg

Max. Lifting Cap. / Front of Lift Center
 4,500 lbs. / 2,041 kg

Max. Lifting Cap. / Rear of Lift Center
 4,500 lbs. / 2,041 kg

Exceeding the weight capacity of this lift can damage lift and/or property and may cause personal harm, injury or death to operators and/or bystanders. All vehicles MUST be positioned on lift with CENTER OF GRAVITY midway between adapters and/or centered on runways. Damage to lift due to overloading or misuse IS NOT covered under warranty.

LA CAPACITÉ DE LEVAGE MAXIMUM POUR CE LEVAGE EST DÉCRIT CI-DESSOUS

Capacité de Levage Maximale
 9,000 lbs. / 4,082 kg

Max. Capuchon De Levage, / Avant du centre de rétroviseur
 4,500 lbs. / 2,041 kg

Max. Capuchon De Levage, / Arrière du centre de levage
 4,500 lbs. / 2,041 kg

Le dépassement de la capacité de poids de cet éleveur peut endommager l'éleveur et/ou les biens et peut causer des dommages corporels, des blessures voire la mort aux opérateurs et/ou aux passants. Tous les véhicules DOIVENT être placés sur l'éleveur avec le CENTRE DE GRAVITÉ à mi-chemin entre les adaptateurs et/ou au centre des plates. Dommages à soulever dus à la surcharge ou une mauvaise utilisation N'EST PAS couverte par la garantie.

PN 5905402
Max. Cap. Danger 9K
ENG-FRE 5905402
 Size: 4"W x 8.25"H

D₁₂ **A DANGER**

THE MAXIMUM LIFTING CAPACITY FOR THIS LIFT IS DESCRIBED BELOW

Maximum Lifting Capacity
 12,000 lbs. / 5,443 kg

Max. Lifting Cap. / Front of Lift Center
 6,000 lbs. / 2,722 kg

Max. Lifting Cap. / Rear of Lift Center
 6,000 lbs. / 2,722 kg

Exceeding the weight capacity of this lift can damage lift and/or property and may cause personal harm, injury or death to operators and/or bystanders. All vehicles MUST be positioned on lift with CENTER OF GRAVITY midway between adapters and/or centered on runways. Damage to lift due to overloading or misuse IS NOT covered under warranty.

LA CAPACITÉ DE LEVAGE MAXIMUM POUR CE LEVAGE EST DÉCRIT CI-DESSOUS

Capacité de Levage Maximale
 12,000 lbs. / 5,443 kg

Max. Capuchon De Levage, / Avant du centre de rétroviseur
 6,000 lbs. / 2,722 kg

Max. Capuchon De Levage, / Arrière du centre de levage
 6,000 lbs. / 2,722 kg

Le dépassement de la capacité de poids de cet éleveur peut endommager l'éleveur et/ou les biens et peut causer des dommages corporels, des blessures voire la mort aux opérateurs et/ou aux passants. Tous les véhicules DOIVENT être placés sur l'éleveur avec le CENTRE DE GRAVITÉ à mi-chemin entre les adaptateurs et/ou au centre des plates. Dommages à soulever dus à la surcharge ou une mauvaise utilisation N'EST PAS couverte par la garantie.

PN 5905404
Max. Cap. Danger 12K
ENG-FRE 5905404
 Size: 4"W x 8.25"H

E₉ **A ATTENTION**

MAXIMUM LIFTING CAPACITY
CAPACITÉ DE LEVAGE MAXIMUM

9000 Lbs.
4082 Kg.

PN 5905650
NRTL Lifting Cap 9K ENG-FRE 5905650
 Size: 4.5"W x 3.25"H

E₁₂ **A ATTENTION**

MAXIMUM LIFTING CAPACITY
CAPACITÉ DE LEVAGE MAXIMUM

12000 Lbs.
5443 Kg.

PN 5905660
NRTL Lifting Cap 12K ENG-FRE 5905660
 Size: 4.5"W x 3.25"H

L

CALIFORNIA PROPOSITION 65
WARNING
 WARNING! This product can expose you to chemicals including styrene and vinyl chloride which are on the list of over 900 chemicals identified by the State of California to cause cancer, birth defects or reproductive harm. ALWAYS use this product in accordance with the manufacturer's instructions. For more information, go to www.p65warnings.ca.gov. PN 5905775

PN 5905775
Prop_65_Label-5905775
 Size: 1.5"W x 1.5"H

F

ALI Blue Label P/N 5905109
 (Kit includes Blue, Yellow & Orange Labels)

Order ALL these labels from ALI

ALI Yellow Label

ALI Orange Label

Order ALL these labels from ALI

J

TO RAISE LIFT:

1. Press and hold **UP** button.
2. When lift is just **PAST** desired height, release **UP** button.
3. Hold down Lowering Handle. **DO NOT** hold down Safety Lock Release Handle. Lift engages on safety locks.
4. Release Lowering Handle.

TO LOWER LIFT:

1. Press and hold **UP** button for two to three seconds, moving lift off safety locks.
2. Hold down Safety Lock Release Handle and Lowering Handle.
3. When lift is fully lowered, release both handles.

PN 5906113
2-Post_Lock-Release_Label_Verical_5906113
 Size: 2"W x 3.75"H

K



PN 5906044
American_Owned_60_Years_Decal-5906163
 Trim: 4"W x 3"H

I

NOTICE

If attachments, accessories, or configuration modifying components used on this lift are located in the load path and affect operation of the lift, affect the lift electrical listing, or affect intended vehicle accommodations; and if they are not certified for use on this lift, then the certification of this lift shall become null and void. Contact the participant for information pertaining to certified attachments, accessories, or configuration modifying components.

www.autolift.org ©2011 by ALI, Inc. ALI / WLSIA01

ALI_Notice_Label.jpg
 Size: 3"W x 1.75"H

G

PLEASE READ

Internal packing oil may cause the cylinders to bleed oil during start up. This is normal. To extend cylinder and seal life, raise the lift to full height at least once every day.

PN 5905177
2-Post Red Cylinder
 Size: 3"W x 1.75"H

H

BendPak 30440 Agoura Road, Agoura Hills, CA 91301 USA

MODEL NO. / N° DE MODÈLE	SERIAL NO. / N° DE SÉRIE
DESCRIPTION	
LIFT CAPACITY / CAPACITÉ DE LEVAGE	
UPC	DATE CODE
VER.	REV.

SCAN TO FIND LATEST MANUAL & PARTS LIST

⚠ DANGER!
 Disconnect Power Before Servicing / Débrancher l'alimentation avant l'entretien

WARRANTY VOID IF DATA PLATE IS REMOVED / GARANTIE NULLE SANS LA PLAQUE D'INFORMATION

MADE IN CHINA / FABRIQUÉ EN CHINE

PN 5906156
BendPak_3x3-Nameplate_Label_A_5906156
 Size: 3"W x 3"H

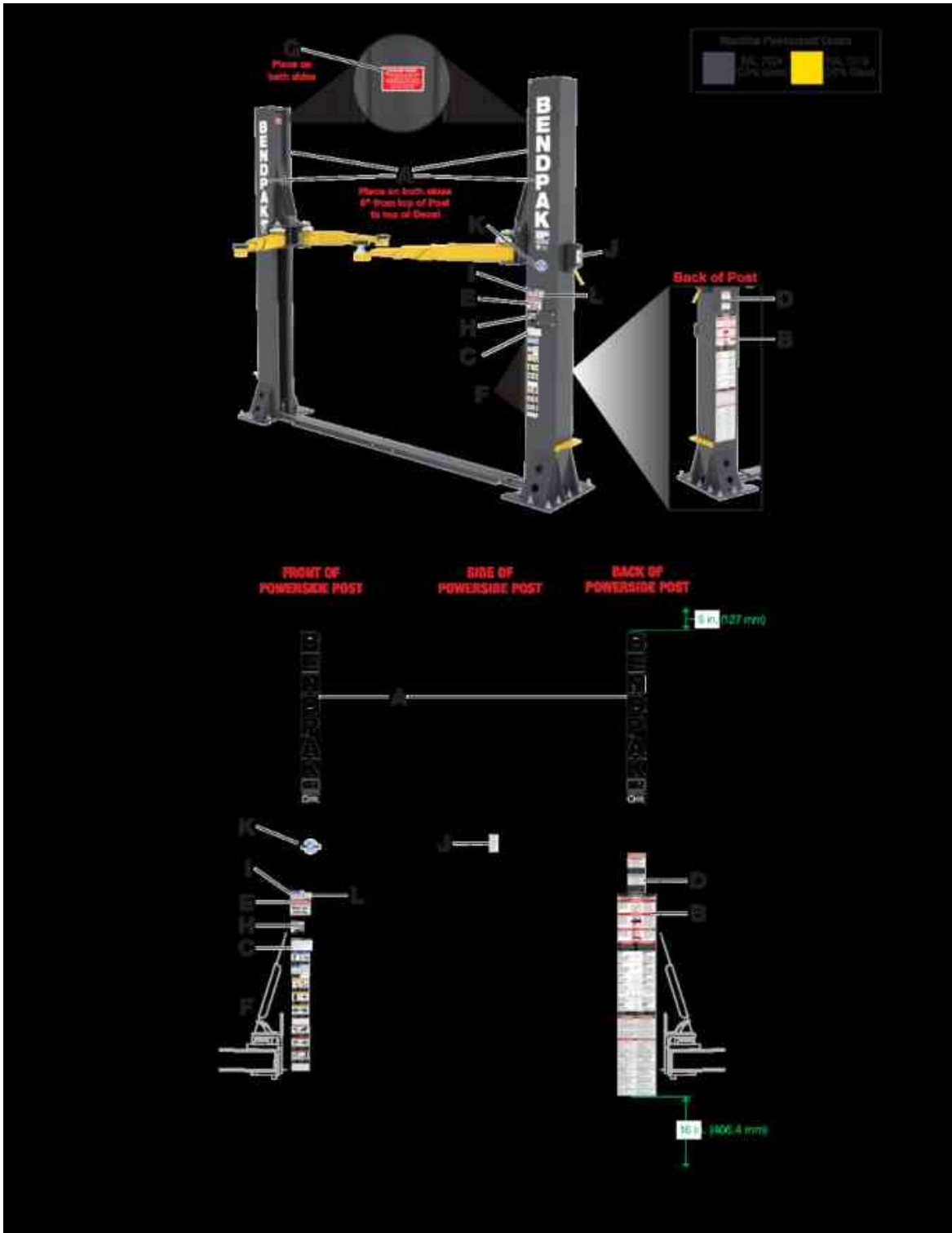

Parts Drawings

REVISION			
REV	DESCRIPTION	DATE	EDITED BY/ECO#
E	UPDATED BOM REVISION	10/17/2024	TM 01574
F	ASSIGNED PART NUMBER, UPDATED BOM REVISIONS	12/27/2024	CA 01579
G	UPDATED BOM REVISIONS, ADDED PRE-INSTALLATION INSTRUCTION (PG.4)	03/07/2025	CA 01587

ITEM NO.	PART NUMBER	DESCRIPTION	QTY.
1	5245295	9APF LIFT SUPERSTRUCTURE	1
2	5250385	9APF PARTS BOX	1
3	5216216	9APF/10AP TRIPLE TELESCOPING ARM ASSEMBLY, LONG	2
4	5216217	9APF/10AP TRIPLE TELESCOPING ASYMMETRIC ARM ASSEMBLY, LEFT	1
5	5216218	9APF/10AP TRIPLE TELESCOPING ASYMMETRIC ARM ASSEMBLY, RIGHT	1
6	5216317	9APF TOP PLATE ASSEMBLY	2
7	REF	POWER UNIT	1

ISOMETRIC VIEW FOR REFERENCE ONLY
DO NOT SCALE

NOTE: UNLESS OTHERWISE SPECIFIED.
1. REFER TO MODEL FOR ADDITIONAL INFORMATION
2. SEE COLORS & GRAPHICS FOR LABEL PLACEMENT
3. SEE SHIPPING INSTRUCTIONS FOR FINAL PACKAGING
4. POWER UNIT REFERENCE ON PURCHASE ORDER

DO NOT SCALE DRAWING

DRAWN: NAME: DATE: 10/09/2023
RK
CHECKED: 30440 AGOURA RD, AGOURA HILLS, CA 91301
THIRD ANGLE PROJECTION
TITLE: 9APF PRODUCTION LIFT VER A
SIZE: DWG. NO.: 5260722
REV: A
SCALE: 1:30
SHEET 1 OF 4

[91.022 OR 101.022 in]
2312.0 OR 2566.0mm
DRIVE THROUGH

[22.071 MIN - 47.610mm MAX]
560.6 MIN - 1209.3mm MAX

[9.457in]
240.2mm

[29.405 MIN - 56.944in MAX]
746.9 MIN - 1446.4mm MAX

[135.945 OR 145.945 in]
3453.0 OR 3707.0mm

[129.488 OR 139.488 in]
3289.0 OR 3543.0mm

[108.228 OR 118.228 in]
2749.0 OR 3003.0mm

[73.373in]
1863.7mm
RAISED

[69.931in]
1776.2mm

[123.150in]
3128.0mm

[4.609in]
117.1mm
LOWERED

55.0mm (2.165in)
ADJUSTMENT

[1.417in]
36.0mm

BP BandPak
30440 AGOURA RD,
AGOURA HILLS, CA 91301
TITLE: 9APF PRODUCTION LIFT VER A
SIZE: DWG. NO.: 5260722
REV: A
SCALE: 1:28
SHEET 2 OF 4

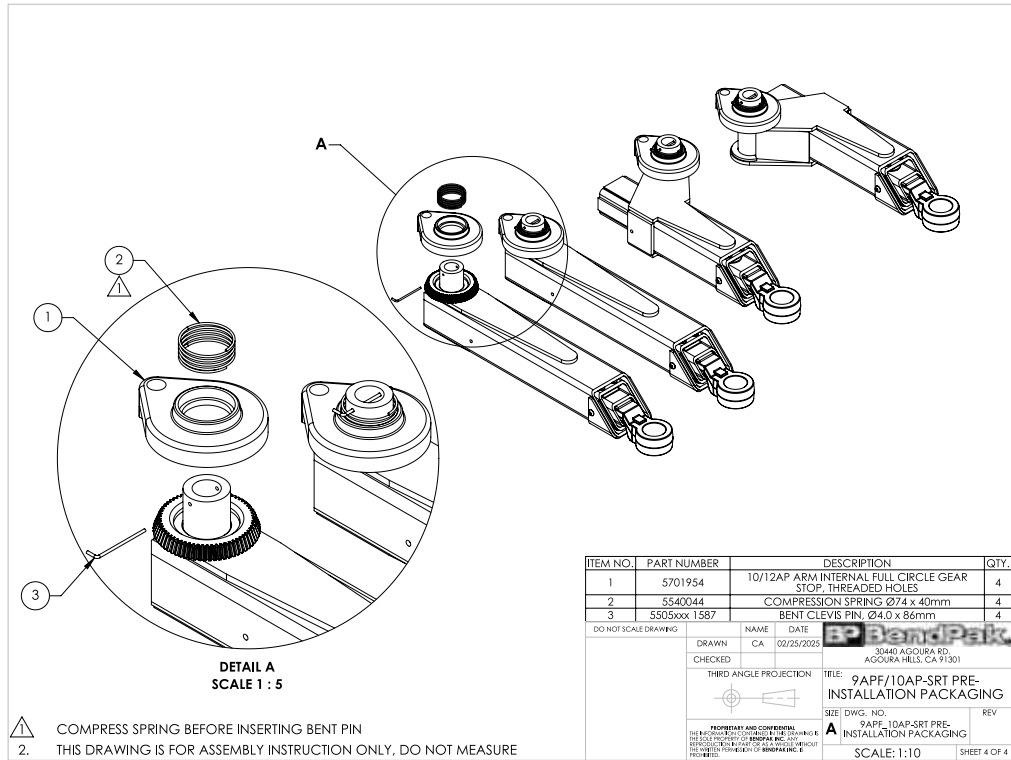
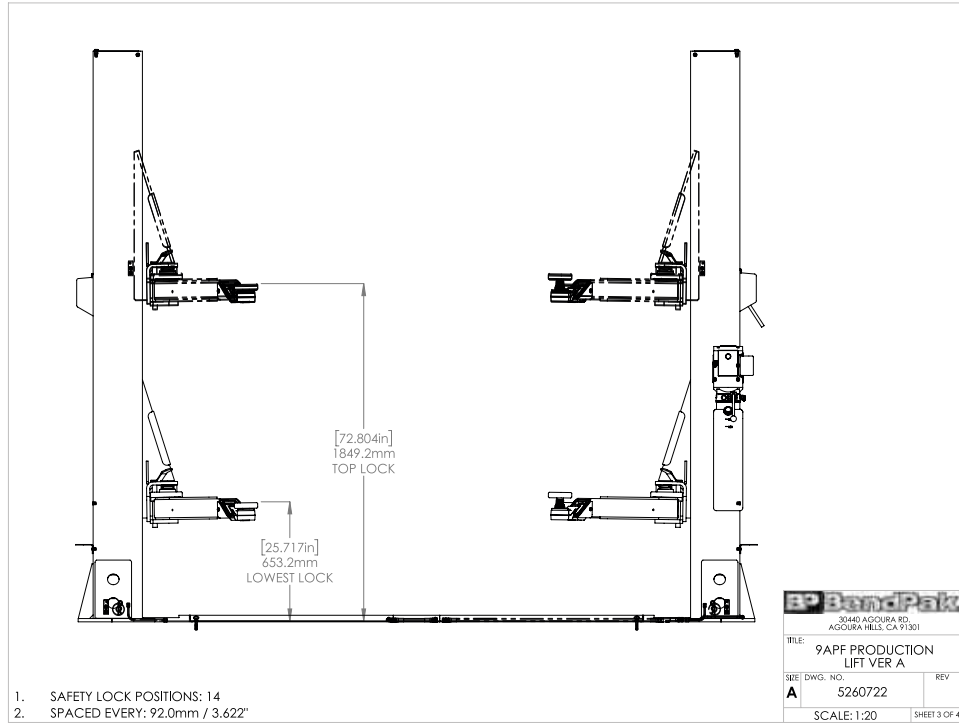

REV	DESCRIPTION	REVISION	DATE	EDITED BY	ECO#
A	PRODUCTION RELEASE. DERIVED FROM 5174125		06/07/2024	TM	01554
B	ASSIGNED PART NUMBER, UPDATED NEXT ASSEMBLY		12/18/2024	CA	01579
C	REPLACED 14) 5530065 WITH 5530472; REMOVED 4) 5535013 AND 4) 5545341; REMOVED 5545005 AND 5535357		02/24/2025	CA	01587

ITEM NO.	PART NUMBER	DESCRIPTION	QTY
1	5530423	SSS M6 x 1.0 x 12 CONE, CL 10.9	8
2	5530472	BHSS M6 x 1.0 x 12 FT, CL 10.9	4
3	5530065	BHSS M6 x 1.0 x 20 FT, CL 10.9	4
4	5530084	FTG ELB -04 NPT x -04 JIC	2
5	5550103	FTG ELB -04 JIC -06 ORB	1
6	5530010	HBB M8 x 1.25 x 25 FT, CL 10.9	4
7	5535001	NUT M8 x 1.25 NL, CL 10.9	2
8	5545202	WASHER M8 x Ø15 SL, CL 10.9	6
9	5530412	HBB M8 x 1.25 x 30 CL 10.9	1
10	5530413	BHSS M8 x 1.25 x 45 CL 10.9	1
11	5535354	NUT M12 x 1.75, CL 10.9	2
12	5545347	WASHER M12 x 24 FLAT, CL 10.9	2
13	5535013	NUT M10 x 1.5 NL, CL 10.9	4
14	5545341	WASHER M10 x Ø20 FLAT, CL 10.9	8
15	5530106	HBB M10 x 1.5 x 35 FT, CL 10.9	4
16	5560012	LIQUID PTFE THREAD SEALANT 50ml	1
17	5550095	FTG NPL -04 JIC x -04 JIC	5
18	5550153	FTG ELB -04 NPT x -04 JIC	1
19	5550181	FTG TEE -04 JIC x -04 JIC x 04 NPT	1

WHERE USED
9APF

NOTE: UNLESS OTHERWISE SPECIFIED.
1. SEE SHIPPING INSTRUCTIONS FOR FINAL PACKAGING

NEXT ASSEMBLY
5250385

DO NOT SCALE DRAWING

DRAWN	TM	DATE	06/07/2024
CHECKED			

THIRD ANGLE PROJECTION

PROPRIETARY AND CONFIDENTIAL
THE INFORMATION CONTAINED HEREIN IS UNCLASSIFIED EXCEPT WHERE SHOWN OTHERWISE AND IS TO BE RELEASED WITHOUT LIMITATION TO THE PUBLIC BY BENDPAK INC.

SCALE: 1:3

SHEET 1 OF 1

REV	DESCRIPTION	REVISION	DATE	EDITED BY	ECO#
A	SAMPLE RELEASE, DERIVED FROM 5215704		03/23/2023	CA	01536
A-001	PRODUCTION RELEASE		02/08/2024	TM	

WHERE USED
9APF
10AP SERIES
10AP-SRT
XPR-9TF*
XPR-9SBT*

NOTE: UNLESS OTHERWISE SPECIFIED.
1. REFER TO MODEL FOR ADDITIONAL INFORMATION
2. SEE SHIPPING INSTRUCTIONS FOR FINAL PACKAGING
3. ASSEMBLE ITEMS AS SHOWN

NEXT ASSEMBLY
5216520
5250385
5250401
5250402
5250403
5250404
5250411

DO NOT SCALE DRAWING

DRAWN	CA	DATE	03/23/2023
CHECKED			

THIRD ANGLE PROJECTION

PROPRIETARY AND CONFIDENTIAL
THE INFORMATION CONTAINED HEREIN IS UNCLASSIFIED EXCEPT WHERE SHOWN OTHERWISE AND IS TO BE RELEASED WITHOUT LIMITATION TO THE PUBLIC BY BENDPAK INC.

SCALE: 1:3

SHEET 1 OF 1

REVISION			
REV	DESCRIPTION	DATE	EDITED BY
C	UPDATED BOM REVISIONS	02/05/2024	TM 01538
D	UPDATED BOM REVISIONS	04/23/2024	TM 01547
E	UPDATED BOM REVISION, REMOVED TEETH PAINT NOTE	08/08/2024	TM 01564

ITEM NO	PART NUMBER	DESCRIPTION	QTY
1	5601937	9APF/10AP LONG ARM WELDMENT, OUTER	1
2	5601936	9APF/10AP LONG ARM WELDMENT, MIDDLE	1
3	5601512	9APF/10AP LONG ARM WELDMENT, INNER	1
4	5737188	AP MIDDLE ARM SLIDE STOP	1
5	5530352	PHSS M10 x 1.25 x 1/2 CL10.9	2
6	5530479	BHSS M10 x 1.5 x 20 FT. CL10.9 B.O.	2

WHERE USED
9APF
10AP SERIES
10AP-SRT

NOTE: UNLESS OTHERWISE SPECIFIED.

- REFER TO MODEL FOR ADDITIONAL INFORMATION
- REMOVE WELD SPLATTER
- SEE SHIPPING INSTRUCTIONS FOR FINAL PACKAGING
- ASSEMBLE ITEMS AS SHOWN
- MASK BORE AND ALL THREADS BEFORE PAINTING
- APPLY LOCTITE BLUE 242 AND CURE PER MANUFACTURE SPECIFICATION
- DIMENSIONS SHOWN ARE AFTER WELDING AND PAINTING
- PAINT YELLOW (RAL-1018) 20% GLOSS

REVISION	DATE	BY	DESCRIPTION
1	04/20/2023	TM	INITIAL RELEASE

REV	DATE	BY	DESCRIPTION
A	08/08/2024	TM	REMOVED TEETH, PAINT NOTE

SECTION A-A
SCALE 1 : 4

BendPak	
1645 LEMONWOOD DR SANTA PAULA, CA 93060	
TITLE: 9APF/10AP TRIPLE TELESCOPING ARM ASSEMBLY, LONG	
SIZE: DWG. NO.	REV
A	5216216
SCALE: 1:6 SHEET 2 OF 2	

REVISION				
REV	DESCRIPTION	DATE	EDITED BY	ECO#
C	UPDATED BOM REVISIONS	02/05/2024	TM	01536
D	UPDATED BOM REVISION	04/15/2024	TM	01547
E	UPDATED BOM REVISION, REMOVED TEETH PAINT NOTE	08/08/2024	TM	01564

**ISOMETRIC VIEW
FOR REFERENCE ONLY
DO NOT SCALE**

WHERE USED

9APF
10AP SERIES
10AP-SRT

NOTE: UNLESS OTHERWISE SPECIFIED.

- REFER TO MODEL FOR ADDITIONAL INFORMATION
- REMOVE WELD SPLATTER
- SEE SHIPPING INSTRUCTIONS FOR FINAL PACKAGING
- ASSEMBLE ITEMS AS SHOWN
- MASK BORE AND ALL THREADS BEFORE PAINTING
- DIMENSIONS SHOWN ARE AFTER WELDING AND PAINTING PAINT YELLOW (RAL-1018) 20% GLOSS
-
- APPLY LOCTITE BLUE 242 AND CURE PER MANUFACTURE SPECIFICATION

ITEM NO	PART NUMBER	DESCRIPTION	QTY
1	5601938	9APF/10AP ASYMMETRIC OUTER ARM WELDMENT, LEFT	1
2	5601753	9APF/10AP ASYMMETRIC ARM WELDMENT, MIDDLE	1
3	5601752	9APF/10AP ASYMMETRIC ARM WELDMENT, INNER	1
4	5737188	AP MIDDLE ARM SLIDE STOP	1
5	5530382	FHSS M8 x 1.25 x 12 CL 10.9	2
6	5530479	BHSS M10 x 1.5 x 20 FT. CL 10.9 B.O.	2

DO NOT SCALE DRAWING

DRAWN	TM	DATE	04/21/2023
CHECKED			

THIRD ANGLE PROJECTION

1645 LEMONWOOD DR.
SANTA PAULA, CA 93060

TITLE: 9APF/10AP TRIPLE
TELESCOPING ASYMMETRIC
ARM ASSEMBLY, LEFT

SIZE: DWG. NO. A 5216217

SCALE: 1:5 SHEET 1 OF 2

NEXT ASSEMBLY	DIMENSIONS ARE IN MM
5260722	☺
5260726	
5260727	
5260728	
5260729	
5260736	

SECTION A-A

BendPak

1645 LEMONWOOD DR.
SANTA PAULA, CA 93060

TITLE: 9APF/10AP TRIPLE
TELESCOPING ASYMMETRIC
ARM ASSEMBLY, LEFT

SIZE: DWG. NO. A 5216217

SCALE: 1:5 SHEET 2 OF 2

REVISION				
REV	DESCRIPTION	DATE	EDITED BY	ECO#
D	UPDATED BOM REVISION	08/07/2024	TM	01564
E	ASSIGNED PART NUMBER, REPLACED 5210251 WITH 5216318, UPDATED BOM REVISIONS AND NEXT ASSEMBLY	12/27/2024	CA	01579
F	ADDED 5535057xxx1551 AND 5535057xxx1586, UPDATED BOM REVISIONS	02/21/2025	CA	01587

ITEM NO	PART NUMBER	DESCRIPTION	QTY
1	5602057	9APF POWER SIDE POST WELDMENT	1
2	5216314	9APF LIFT HEAD ASSEMBLY	1
3	5502065	CYLINDER ASSEMBLY Ø2.5 x 34.5" SINGLE PORT	1
4	5216318	9APF CHAIN SHEAVE ASSEMBLY	1
5	5216323	CYLINDER CHAIN ASSEMBLY 2665mm	1
6	5575111	9APF SHEAVE ASSEMBLY Ø127mm	2
7	5545004	WASHER Ø25 x Ø63 FLAT	2
8	5505350	HAIR PIN 1/8" x 2 9/16"	2
9	5602087	9APF/10AP-SRT POWER SIDE SAFETY BLOCK WELDMENT	1
10	5746494	AP SAFETY PIVOT PIN	1
11	5530414	BHSC M8 x 1.25 x 25 CL10.9	1
12	5545202	WASHER M8 x Ø15 SL CL10.9	1
13	5540047	EXTENSION SPRING Ø6.35 x 38mm	2
14	5530045	BHPS M5 x 0.8 x 10 FT. CL 8.8	4
15	5575074	AP SAFETY CABLE ROLLER	1
16	5565350	SAFETY SHEAVE SPACER, 11.5mm	1
17	5530756	HHB M6 x 1.0 x 25 FT. CL 10.9	1
18	5535357	NUT M6 x 1.0 NL CL10.9	1
19	5575325	SAFETY CABLE SHEAVE Ø50mm	1
20	5530407	BHSS M8 x 1.25 x 40 FT. CL 10.9	1
21	5535001	NUT M8 x 1.25 NL CL10.9	1
22	5535057	NUT M8 x 1.25 x 17.5, RIVET	4
23	5535057x1551	NUT M6 x 1.0 x 18, RIVET	4
24	5535057x1586	NUT M10 x 1.5 x 20.5, RIVET	2
25	5761003	PL-7000DLX/9APF CHAIN CONNECTOR	1
26	5530761	SHCS M10 x 1.5 x 55	2
27	5535013	NUT M10 x 1.5 NL CL10.9	2

WHERE USED
9APF

NOTE: UNLESS OTHERWISE SPECIFIED.
 1. REFER TO MODEL FOR ADDITIONAL INFORMATION
 2. SEE SHIPPING INSTRUCTIONS FOR FINAL PACKAGING
 3. ASSEMBLE ITEMS AS SHOWN

NEXT ASSEMBLY
5245295

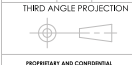
DO NOT SCALE DRAWING	NAME	DATE	BP BandPak 30440 AGOURA RD. AGOURA HILLS, CA 91301
DRAWN	RK	09/08/2023	
CHECKED			TITLE: 9APF POWER SIDE POST ASSEMBLY
DIMENSIONS ARE IN MM			REV
THIRD ANGLE PROJECTION			SCALE: 1:18
			SHEET 1 OF 2
<small>PROPRIETARY AND CONFIDENTIAL THIS INFORMATION IS CONTAINED HEREIN IN WHOLE OR IN PART IS THE PROPERTY OF BANDPAK INC. AND IS TO BE KEPT SECRET BY THE USER. THE USER AGREES TO HOLD BANDPAK INC. HARMLESS FROM ANY AND ALL CLAIMS, DAMAGES, LOSSES AND EXPENSES, INCLUDING REASONABLE ATTORNEY'S FEES, THAT MAY BE ASSERTED AGAINST BANDPAK INC. BY ANY THIRD PARTY AS A RESULT OF THE USER'S FAILURE TO MAINTAIN THE CONFIDENTIALITY OF THIS INFORMATION.</small>			

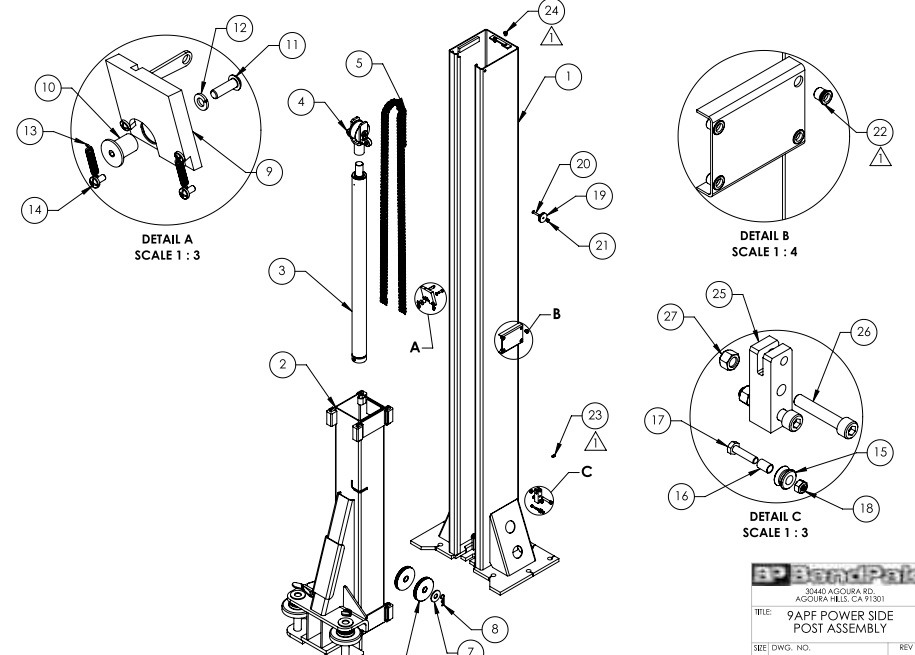

INSTALL RIVET NUTS INTO POST AND POST BRACKET AS SHOWN

BP BandPak	
<small>30440 AGOURA RD. AGOURA HILLS, CA 91301</small>	
TITLE: 9APF POWER SIDE POST ASSEMBLY	
REV	REV
A	5216312
SCALE: 1:18	
SHEET 2 OF 2	

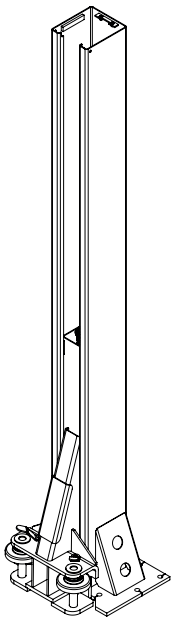

REVISION				
REV	DESCRIPTION	DATE	EDITED BY	ECO#
D	UPDATED BOM REVISIONS	08/07/2024	TM	01564
E	ASSIGNED PART NUMBER, REPLACED 5210251 WITH 5216318, UPDATED BOM REVISIONS AND NEXT ASSEMBLY	12/19/2024	CA	01579
F	ADDED 5535057xxx1551 AND 5535057xxx1586, UPDATED BOM REVISIONS	02/21/2025	CA	01587

ITEM NO	PART NUMBER	DESCRIPTION	QTY
1	5602067	9APF OFF SIDE POST WELDMENT	1
2	5216314	9APF LIFT HEAD ASSEMBLY	1
3	5502065	CYLINDER ASSEMBLY Ø2.5 x 34.5" SINGLE PORT	1
4	5216318	9APF CHAIN SHEAVE ASSEMBLY	1
5	5214323	CYLINDER CHAIN ASSEMBLY, 2665mm	1
6	5575111	9APF SHEAVE ASSEMBLY, Ø127mm	2
7	5545004	WASHER Ø25 x Ø63 FLAT	2
8	5505350	HAIR PIN 1/8" x 2.9171"	2
9	5602081	9APF/10AP-SRT OFF SIDE SAFETY BLOCK WELDMENT	1
10	5746494	AP SAFETY PIVOT PIN	1
11	5530414	BHSC M8 x 1.25 x 25 CL10.9	1
12	5545202	WASHER M8 x Ø15 SL, CL10.9	1
13	5540047	EXTENSION SPRINGS Ø6.35 x 38mm	2
14	5530045	BHPS M5 x 0.8 x 10 FT, CL 9.8	4
15	5575074	AP SAFETY CABLE ROLLER	1
16	5565350	SAFETY SHEAVE SPACER, 11.5mm	1
17	5530756	HBB M6 x 1.0 x 25 FT, CL 10.9	1
18	5535357	NUT M6 x 1.0 NL, CL10.9	1
19	5575325	SAFETY CABLE SHEAVE, Ø50mm	2
20	5530407	BHSS M8 x 1.25 x 40 FT, CL 10.9	2
21	5535001	NUT M8 x 1.25 NL, CL10.9	2
22	5761003	PL-7000DLX/9APF CHAIN CONNECTOR	1
23	5530761	SHCS M10 x 1.5 x 55	2
24	5535013	NUT M10 x 1.5 NL, CL10.9	2
25	5535057XXX1551	NUT M6 x 1.0 x 18, RIVET	4
26	5535057XXX1586	NUT M10 x 1.5 x 20.5, RIVET	2

WHERE USED
9APF

NOTE: UNLESS OTHERWISE SPECIFIED.
1. REFER TO MODEL FOR ADDITIONAL INFORMATION
2. SEE SHIPPING INSTRUCTIONS FOR FINAL PACKAGING
3. ASSEMBLE ITEMS AS SHOWN

NEXT ASSEMBLY
5245295



 DRAWN: RIK 09/08/2023
 CHECKED: []
 DIMENSIONS ARE IN MM
 THIRD ANGLE PROJECTION
 TITLE: 9APF OFF SIDE POST ASSEMBLY
 SRE: DWG. NO.: 5216313
 SCALE: 1:18 SHEET 1 OF 2

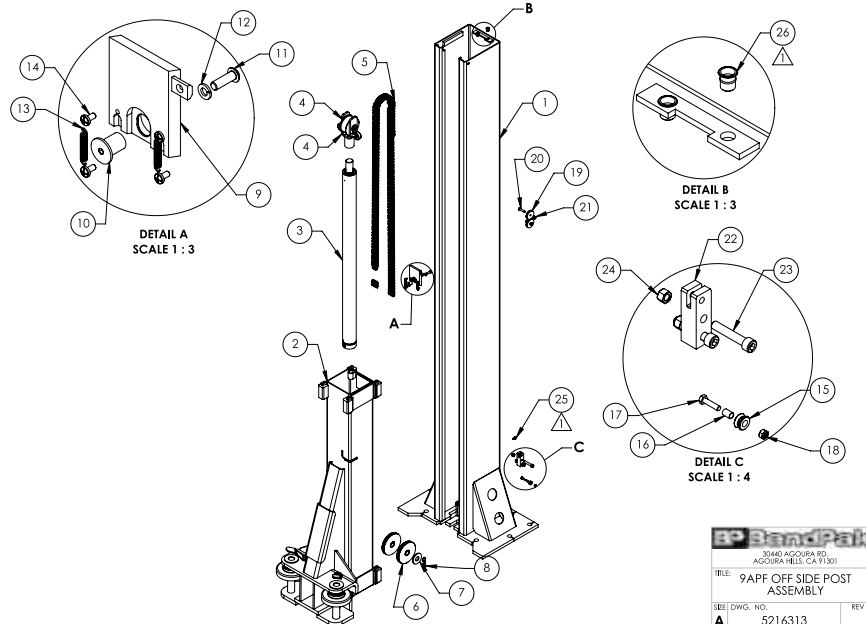

DETAIL A
SCALE 1 : 3

DETAIL B
SCALE 1 : 3

DETAIL C
SCALE 1 : 4

▲ INSTALL RIVET NUTS INTO POST AS SHOWN



 TITLE: 9APF OFF SIDE POST ASSEMBLY
 SRE: DWG. NO.: 5216313
 SCALE: 1:18 SHEET 2 OF 2

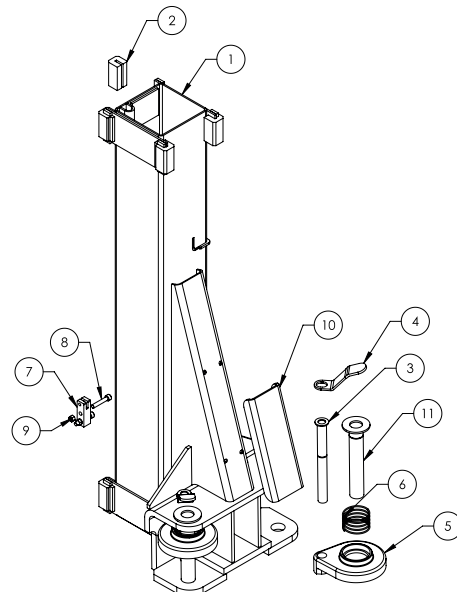

REVISION				
REV	DESCRIPTION	DATE	EDITED BY	ECO#
C	UPDATED BOM REVISION	08/07/2024	TM	01564
D	ASSIGNED PART NUMBER, UPDATED BOM REVISION AND NEXT ASSEMBLIES	12/19/2024	CA	01579
E	ADDED 5601505, UPDATED BOM REVISION	04/01/2025	CA	01587

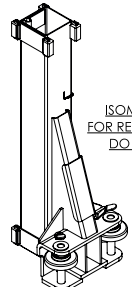

ISOMETRIC VIEW
FOR REFERENCE ONLY
DO NOT SCALE

ITEM NO.	PART NUMBER	DESCRIPTION	QTY.
	5602069	9APF LIFT HEAD WELDMENT	1
2	5716001	2 POST GUIDE BLOCK	8
3	5602029	9APF/10AP/SRT ARM LOCK GUIDE ROD WELDMENT, GROOVE	2
4	5701700	AP ARM LOCK RELEASE HANDLE	2
5	5701954	10/12AP ARM INTERNAL FULL CIRCLE GEAR STOP, THREADED HOLES	2
6	5540044	COMPRESSION SPRING Ø74 x 40mm	2
7	5761003	PL-7000DLX/9APF CHAIN CONNECTOR	1
8	5530741	SHCS M10 x 1.5 x 55	2
9	5535013	NUT M10 x 1.5 NL, CL10.9	2
10	5930003	9APF/10AP/SRT LIFT HEAD GUSSET COVER	1
11	5601505	9APF/10AP/SRT ARM LOCK PIN WELDMENT, Ø38mm	2

WHERE USED
9APF

NOTE: UNLESS OTHERWISE SPECIFIED.
1. REFER TO MODEL FOR ADDITIONAL INFORMATION
2. SEE SHIPPING INSTRUCTIONS FOR FINAL PACKAGING
3. ASSEMBLE ITEMS AS SHOWN

NEXT ASSEMBLY
5216312
5216313

DO NOT SCALE DRAWING	NAME	DATE	BendPak
DRAWN	RK	09/08/2023	30440 AGOURA RD. AGOURA HILLS, CA 91301
CHECKED			
THIRD ANGLE PROJECTION	TITLE:	9APF LIFT HEAD ASSEMBLY	
☺	SIZE	DWG. NO.	REV
	A	5216314	
		SCALE: 1:10	SHEET 1 OF 2

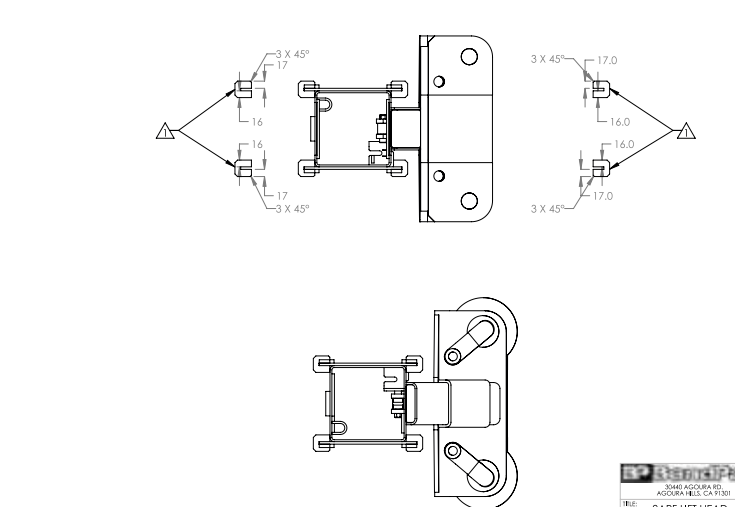

NOTE: UNLESS OTHERWISE SPECIFIED.
▲ NOTE ORIENTATION OF PLASTIC GUIDE BLOCK

TOP VIEW

BendPak			
30440 AGOURA RD. AGOURA HILLS, CA 91301			
TITLE:	9APF LIFT HEAD ASSEMBLY		
SIZE	DWG. NO.	REV	
A	5216314		
	SCALE: 1:7	SHEET 2 OF 2	

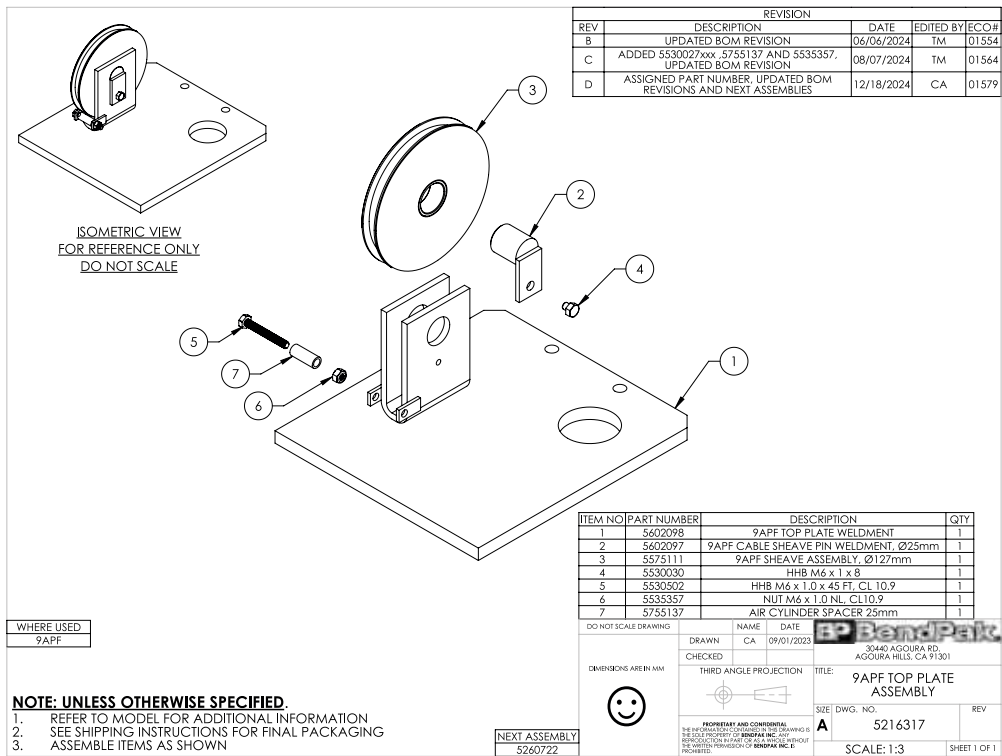
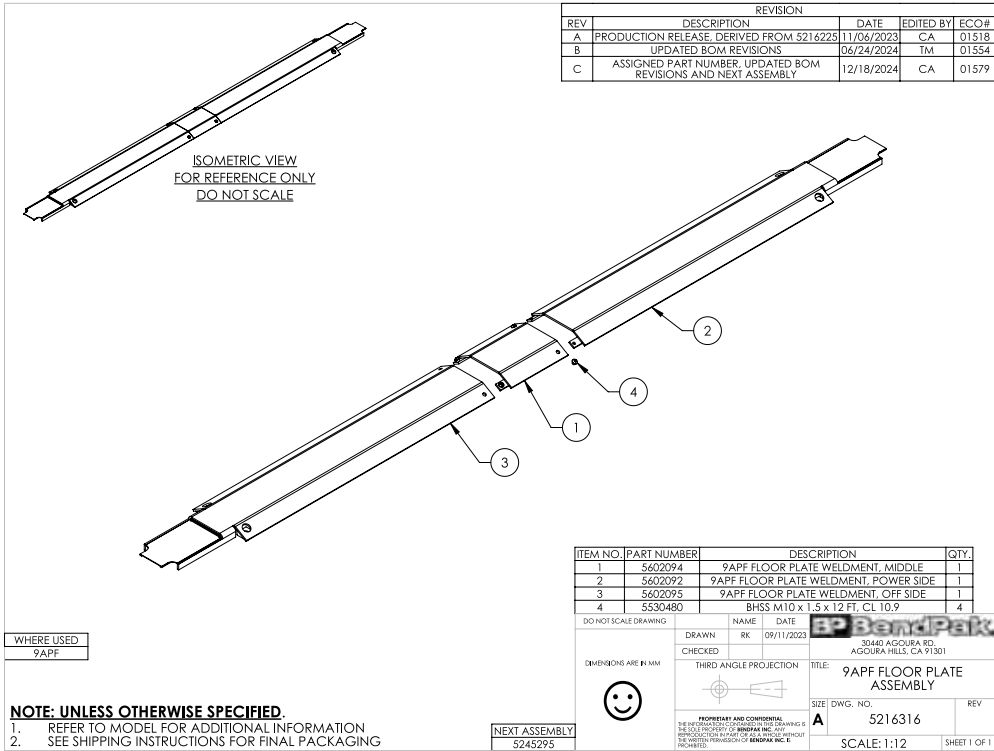

REVISION				
REV	DESCRIPTION	DATE	EDITED BY	ECO#
A	PRODUCTION RELEASE, DERIVED FROM 5210117	11/13/2023	CA	01518
B	UPDATED BOM REVISION	06/09/2024	TM	01554
C	ASSIGNED PART NUMBER, UPDATED BOM REVISIONS AND NEXT ASSEMBLIES	12/18/2024	CA	01579

ISOMETRIC VIEW
FOR REFERENCE ONLY
DO NOT SCALE

ITEM NO	PART NUMBER	DESCRIPTION	QTY
1	5602096	9APF CHAIN SHEAVE BRACKET WELDMENT	1
2	5600082	PL-7000DLX 9APF CHAIN SHEAVE PIN WELDMENT, Ø29mm	1
3	5215073	PL-7000DLX 9APF CHAIN SHEAVE ASSEMBLY, Ø102mm	1
4	5540006	SNAP RING TRUARC 5103-100	1
5	5716113	POLYURETHANE WHEEL, Ø42mm	2
6	5530520	HHB M5 x 0.8 x 35 FT, CL 8.8	2
7	5535142	NUT M5 x 0.8, N1 C18	2

WHERE USED
9APF

NOTE: UNLESS OTHERWISE SPECIFIED.
 1. REFER TO MODEL FOR ADDITIONAL INFORMATION
 2. SEE SHIPPING INSTRUCTIONS FOR FINAL PACKAGING
 3. ASSEMBLE ITEMS AS SHOWN

DRAWN	CHK	DATE	
30440 AGOURA RD. AGOURA HILLS, CA 91301			
THIRD ANGLE PROJECTION			TITLE: 9APF CHAIN SHEAVE ASSEMBLY
SIZE: DWG. NO.			REV
A			5216318
SCALE: 1:2			SHEET 1 OF 1

REVISION				
REV	DESCRIPTION	DATE	EDITED BY	ECO#
D	UPDATED BOM REVISION	10/16/2024	TM	01574
E	ASSIGNED PART NUMBER, REPLACED 5570750 WITH 5570312 AND 5900354 WITH 5900388, UPDATED BOM REVISIONS AND NEXT ASSEMBLIES	12/19/2024	CA	01579
F	REMOVED 5601505, UPDATED BOM REVISIONS	03/07/2025	CA	01587

ITEM NO	PART NUMBER	DESCRIPTION	QTY
1	5174150	9APF PARTS BAG	1
2	5570311	HYDRAULIC HOSE ASSEMBLY Ø6.35 x 1180mm DS	2
3	5570309	HYDRAULIC HOSE ASSEMBLY Ø6.35 x 1316mm DS	1
4	5570256	HYDRAULIC HOSE ASSEMBLY Ø6.35 x 254mm DS	1
5	5570312	HYDRAULIC HOSE ASSEMBLY Ø6.35 x 1335mm SB	1
6	5595856	CABLE ASSEMBLY Ø10 x 10080mm DBST	2
7	5595793	SAFETY CABLE Ø1.8 x 7773mm	1
8	5715003	POWER UNIT VIBRATION DAMPENER	1
9	5601892	APF/SRT SAFETY HANDLE WELDMENT	1
10	5700404	AP SAFETY PIVOT HOLDER	1
11	5716094	APF/SRT PLASTIC SAFETY COVER	2
12	5746167	DOUBLE THREADED ROD M10 x 1.5 x 275	2
13	5216239	ROUND ADJUSTABLE LIFT PAD ADAPTER ASSEMBLY, Ø60mm	4
14	5900388	APF INSTALLATION MANUAL	1
15	5530337	AB 3/4" x 6.3"	18
16	5701660	HEIGHT ADAPTER HOLDER, 60mm	2
17	5216320	9APF HYDRAULIC LINE ASSEMBLY, CYLINDER	2
18	5216321	9APF HYDRAULIC LINE ASSEMBLY, POWER UNIT	1
19	5530326	AB Ø3/8" x 2-1/4"	4

WHERE USED
9APF

NOTE: UNLESS OTHERWISE SPECIFIED.
 1. REFER TO MODEL FOR ADDITIONAL INFORMATION
 2. INSERT PARTS BAG INTO PARTS BOX FOR SHIPMENT
 3. HOSES AND CABLES SHOWN REPRESENTATIONAL FORM

DRAWN	NAME	DATE	
30440 AGOURA RD. AGOURA HILLS, CA 91301			
THIRD ANGLE PROJECTION			TITLE: 9APF PARTS BOX
SIZE: DWG. NO.			REV
A			5250385
SCALE: 1:10			SHEET 1 OF 1

REVISION				
REV	DESCRIPTION	DATE	EDITED BY	ECCO#
A	PRODUCTION RELEASE, DERIVED FROM 5260693	08/04/2024	TM	01542
B	UPDATED BOM REVISION	10/16/2024	TM	01574
C	ASSIGNED PART NUMBER, REPLACED 5216203 WITH 5211009, 5216197 WITH 5211007, AND 5216198 WITH 5211008, UPDATED BOM REVISIONS	06/19/2025	CA	01586

ISOMETRIC VIEW
FOR REFERENCE ONLY
DO NOT SCALE

ITEM NO.	PART NUMBER	DESCRIPTION	QTY.
1	5245296	12APF LIFT SUPERSTRUCTURE	1
2	5250400	12APF PARTS BOX	1
3	5211009	12APX/SRT/APF TRIPLE TELESCOPING ARM, PRE-ASSEMBLY KIT	2
4	5211007	12APX/SRT/APF ASYMMETRIC LEFT ARM, PRE-ASSEMBLY KIT	1
5	5211008	12APX/SRT/APF ASYMMETRIC RIGHT ARM, PRE-ASSEMBLY KIT	1
6	5216330	12APF TOP PLATE ASSEMBLY	2
7	REF	POWER UNIT	1

NOTE: UNLESS OTHERWISE SPECIFIED.

- REFER TO MODEL FOR ADDITIONAL INFORMATION
- SEE COLORS & GRAPHICS FOR LABEL PLACEMENT
- SEE SHIPPING INSTRUCTIONS FOR FINAL PACKAGING

POWER UNIT REFERENCE ON PURCHASE ORDER

30440 AGOURA RD.
AGOURA HILLS, CA 91301

TITLE: 12APF PRODUCTION LIFT VER A

SIZE: DWG. NO. A 5260725

SCALE: 1:35 SHEET 1 OF 3

Top View Dimensions:

- [102.317in] 2598.8mm DRIVE THROUGH
- [25.945 MIN - 55.228in MAX] 659.0 MIN - 1402.8mm MAX
- [9.457in] 240.2mm
- [155.000in] 3937.0mm
- [119.134in] 3026.0mm
- [142.205in] 3612.0mm
- [73.440in] 1865.4mm RAISED
- [70.074in] 1779.9mm
- [11.807in] 299.9mm WITH 63mm [2.5in] AND 125mm [4.9in] ADAPTERS
- [4.462in] 113.3mm LOWERED
- [1.417in] 36.0mm

Side View Dimensions:

- [-1.946 MIN - 56.616 MAX] 49.4mm MIN - 1438.0mm MAX
- [-11.538 MIN - 49.819 MAX] -293.1mm MIN - 1265.4mm MAX
- [144.724in] 3676.0mm

30440 AGOURA RD.
AGOURA HILLS, CA 91301

TITLE: 12APF PRODUCTION LIFT VER A

SIZE: DWG. NO. A 5260725

SCALE: 1:35 SHEET 2 OF 3

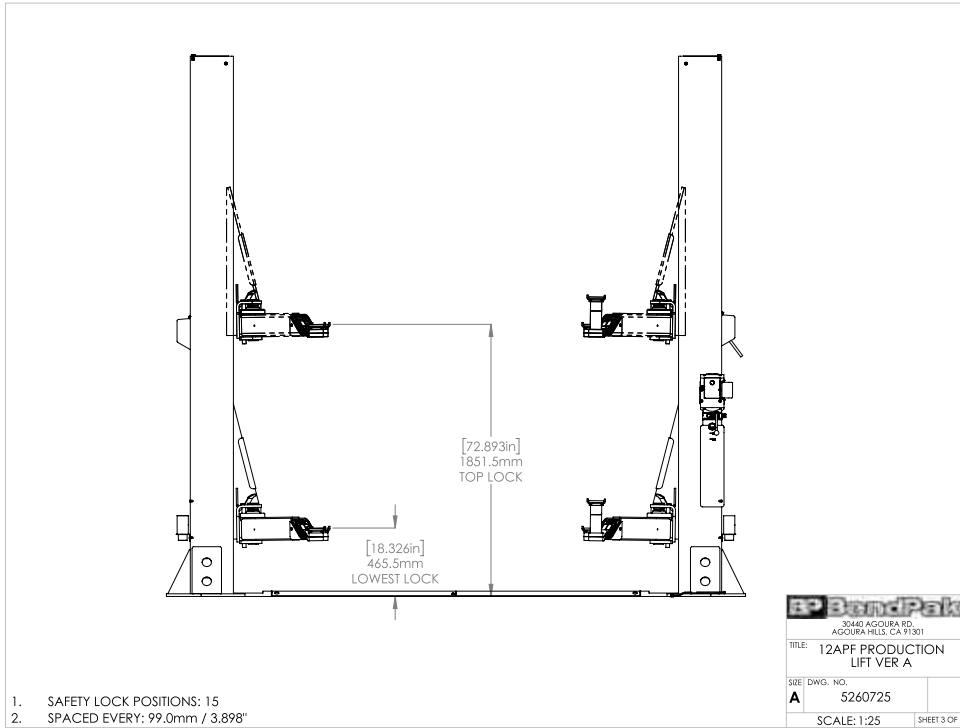

BP BendPak
30440 AGOURA RD.
AGOURA HILLS, CA 91301

TITLE: 12APF PRODUCTION LIFT VER A

SHEET DWG. NO. **A** 5260725

SCALE: 1:25 SHEET 3 OF 3

REV	DESCRIPTION	DATE	EDITED BY	ECO#
A	PRODUCTION RELEASE, DERIVED FROM 5174125	07/26/2024	TM	01562
B	REPLACED (4) 5530065 WITH 5530472 AND (4) 5545341 WITH 5545200, REMOVED (4) 5530119 AND (4) 5545341, REMOVED 5545005 AND 5535357, ASSIGNED PART NUMBER, UPDATED NEXT ASSEMBLY	02/18/2025	CA	01586

ITEM NO.	PART NUMBER	DESCRIPTION	QTY
1	5530423	SSS M6 x 1.0 x 12 CONE, CL 10.9	8
2	5530472	BHSS M6 x 1.0 x 12 FT, CL 10.9	4
3	5530065	BHSS M6 x 1.0 x 20 FT, CL 10.9	4
4	5550147	FTG NPL -04 JIC x -04 NPT	2
5	5550103	FTG ELB -04 JIC -06 ORB	1
6	5530010	HHB M8 x 1.25 x 25 FT, CL 10.9	4
7	5535001	NUT M8 x 1.25 NL, CL10.9	2
8	5545202	WASHER M8 x Ø15 SL, CL10.9	6
9	5530412	BHSS M8 x 1.25 x 30 CL10.9	1
10	5530413	BHSS M8 x 1.25 x 45 CL10.9	1
11	5535354	NUT M12 x 1.75, CL 10.9	2
12	5545347	WASHER M12 x 24 FLAT, CL 10.9	2
13	5535013	NUT M10 x 1.5 NL, CL10.9	4
14	5545341	WASHER M10 x Ø20 FLAT, CL10.9	4
15	5530106	HHB M10 x 1.5 x 35 FT, CL 10.9	4
16	5545200	WASHER M10 x Ø18 SL, CL10.9	4
17	5580012	LIQUID PTFE THREAD SEALANT 50ml	1
18	5550095	FTG NPL -04 JIC x -04 JIC	2
19	5550153	FTG ELB -04 NPT F x -04 JIC	1
20	5550181	FTG TEE -04 JIC x -04 JIC x 04 NPT	1

WHERE USED
12APF

NOTE: UNLESS OTHERWISE SPECIFIED.
1. SEE SHIPPING INSTRUCTIONS FOR FINAL PACKAGING

NEXT ASSEMBLY
5250400

DO NOT SCALE DRAWING

DRAWN: RK 05/24/2024

CHECKED:

THIRD ANGLE PROJECTION

BP BendPak
30440 AGOURA RD.
AGOURA HILLS, CA 91301

TITLE: 12APF PARTS BAG

SHEET DWG. NO. **A** 5174152

SCALE: 1:3 SHEET 1 OF 1

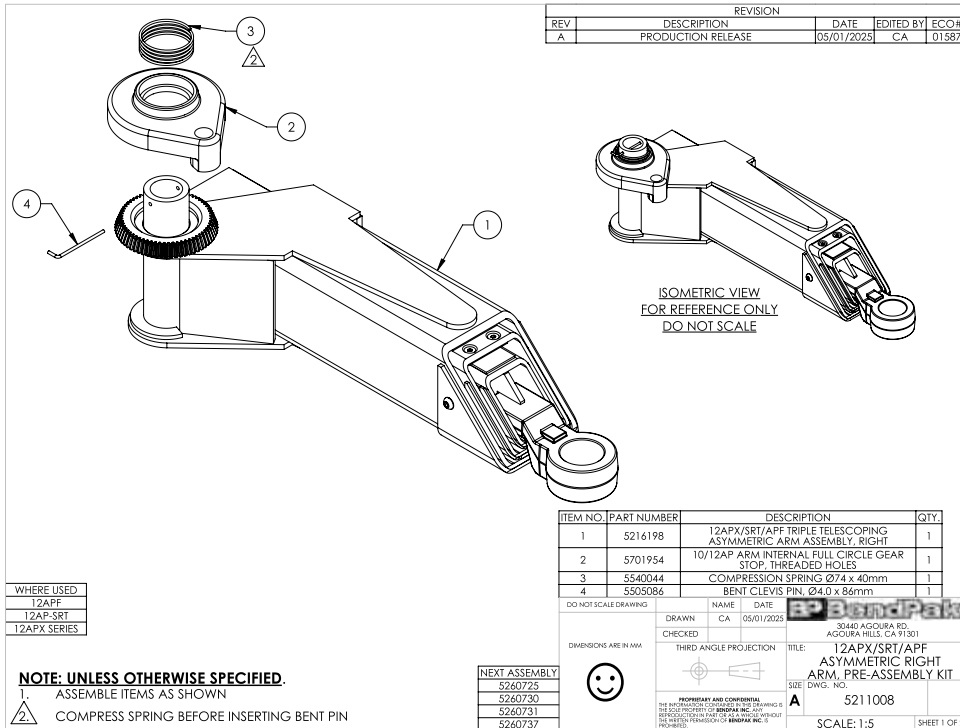
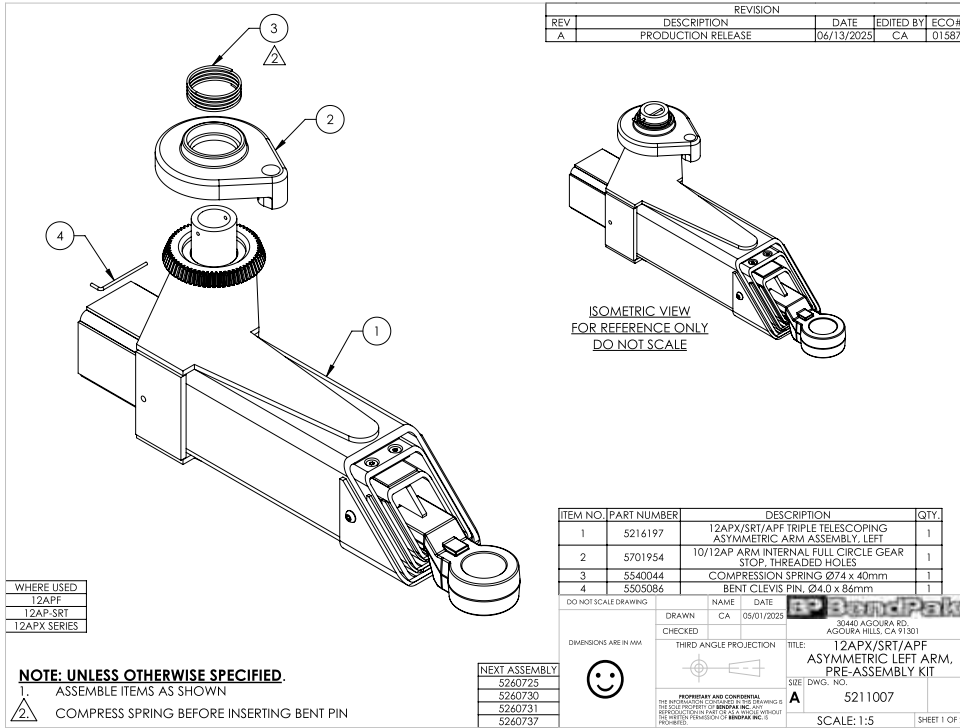

REVISION			
REV	DESCRIPTION	DATE	EDITED BY/ECO#
D	UPDATED BOM REVISIONS	01/31/2024	TM 01536
E	UPDATED BOM REVISIONS	04/12/2024	TM 01547
F	UPDATED BOM REVISION AND REMOVED TEETH PAINT NOTE	08/05/2024	TM 01562

ISOMETRIC VIEW
FOR REFERENCE ONLY
DO NOT SCALE

ITEM NO.	PART NUMBER	DESCRIPTION	QTY.
1	5601899	12APX/SRT/APF ASYMMETRIC ARM WELDMENT, OUTER LEFT TUBE	1
2	5601898	12APX/SRT/APF ASYMMETRIC ARM WELDMENT, MIDDLE TUBE	1
3	5601897	12APX/SRT/APF ASYMMETRIC ARM WELDMENT, INNER TUBE	1
4	5737188	AP MIDDLE ARM SLIDE STOP	1
5	5530382	FHSS M8 x 1.25 x 12 CL10.9	2
6	5530479	BHSS M10 x 1.5 x 20 FT. CL 10.9 B.O.	2

WHERE USED

12APF
12AP-SRT
12APX SERIES

NOTE: UNLESS OTHERWISE SPECIFIED.

- REFER TO MODEL FOR ADDITIONAL INFORMATION
- REMOVE WELD SPLATTER
- SEE SHIPPING INSTRUCTIONS FOR FINAL PACKAGING
- ASSEMBLE ITEMS AS SHOWN
- MASK BORE AND ALL THREADS BEFORE PAINTING
- DIMENSIONS SHOWN ARE AFTER WELDING AND PAINTING
- PAINT YELLOW (RAL-1018) 20% GLOSS
- APPLY LOCTITE BLUE 242 AND CURE PER MANUFACTURE SPECIFICATION

NEXT ASSEMBLY
5211007

NAME	DATE
DRAWN	RK 07/22/2022
CHECKED	

BendPak
1445 LEMMONWOOD DR.
SANTA PAULA, CA 95060

TITLE: 12APX/SRT/APF TRIPLE TELESCOPING ASYMMETRIC ARM ASSEMBLY, LEFT

SHEET DWG. NO. **A** 5216197

SCALE: 1:5 SHEET 1 OF 2

REVISION			
REV	DESCRIPTION	DATE	EDITED BY/ECO#
D	UPDATED BOM REVISION	01/31/2024	TM 01536
E	UPDATED BOM REVISIONS	04/12/2024	TM 01547
F	UPDATED BOM REVISION AND REMOVED TEETH PAINT NOTE	08/06/2024	TM 01562

ISOMETRIC VIEW
FOR REFERENCE ONLY
DO NOT SCALE

ITEM NO.	PART NUMBER	DESCRIPTION	QTY.
1	5601900	12APX/SRT/APF ASYMMETRIC ARM WELDMENT, OUTER RIGHT TUBE	1
2	5601898	12APX/SRT/APF ASYMMETRIC ARM WELDMENT, MIDDLE TUBE	1
3	5601897	12APX/SRT/APF ASYMMETRIC ARM WELDMENT, INNER TUBE	1
4	5737188	AP MIDDLE ARM SLIDE STOP	1
5	5530382	FHSS M8 x 1.25 x 12 CL10.9	2
6	5530479	BHSS M10 x 1.5 x 20 FT. CL 10.9 B.O.	2

WHERE USED

12APF
12AP-SRT
12APX SERIES

NOTE: UNLESS OTHERWISE SPECIFIED.

- REFER TO MODEL FOR ADDITIONAL INFORMATION
- REMOVE WELD SPLATTER
- SEE SHIPPING INSTRUCTIONS FOR FINAL PACKAGING
- ASSEMBLE ITEMS AS SHOWN
- MASK BORE AND ALL THREADS BEFORE PAINTING
- DIMENSIONS SHOWN ARE AFTER WELDING AND PAINTING
- PAINT YELLOW (RAL-1018) 20% GLOSS
- APPLY LOCTITE BLUE 242 AND CURE PER MANUFACTURE SPECIFICATION

NEXT ASSEMBLY
5211008

NAME	DATE
DRAWN	RK 07/22/2022
CHECKED	

BendPak
1445 LEMMONWOOD DR.
SANTA PAULA, CA 95060

TITLE: 12APX/SRT/APF TRIPLE TELESCOPING ASYMMETRIC ARM ASSEMBLY, RIGHT

SHEET DWG. NO. **A** 5216198

SCALE: 1:5 SHEET 1 OF 2

REVISION			
REV	DESCRIPTION	DATE	EDITED BY/ECCO#
D	UPDATED BOM REVISIONS	01/30/2024	TM 01536
E	UPDATED BOM REVISIONS	04/12/2024	TM 01547
F	UPDATED BOM REVISION, REMOVED TEETH PAINT NOTE	08/06/2024	TM 01562

ITEM NO.	PART NUMBER	DESCRIPTION	QTY.
1	5601907	12APX/SRT/APF LONG ARM WELDMENT, OUTER TUBE	1
2	5601908	12APX/SRT/APF LONG ARM WELDMENT, MIDDLE TUBE	1
3	5601909	12APX/SRT/APF LONG ARM WELDMENT, INNER TUBE	1
4	5737188	AP MIDDLE ARM SLIDE STOP	1
5	5530382	FHSS M8 x 1.25 x 12 CL 10.9	2
6	5530479	BHSS M10 x 1.5 x 20 FT. CL 10.9 B.O.	2

WHERE USED
12APF
12AP-SRT
12APX SERIES

NOTE: UNLESS OTHERWISE SPECIFIED.
 1. REFER TO MODEL FOR ADDITIONAL INFORMATION
 2. REMOVE WELD SPLATTER
 3. SEE SHIPPING INSTRUCTIONS FOR FINAL PACKAGING ASSEMBLE ITEMS AS SHOWN
 4. MASK BORE AND ALL THREADS BEFORE PAINTING
 DIMENSIONS SHOWN ARE AFTER WELDING AND PAINTING
 PAINT YELLOW (RAL-1018) 20% GLOSS
 7. APPLY LOCTITE BLUE 242 AND CURE PER MANUFACTURE SPECIFICATION

DO NOT SCALE DRAWING		NAME	DATE
DRAWN	RK	03/23/2022	
CHECKED			
THIRD ANGLE PROJECTION			
DIMENSIONS ARE IN MM			

PROPRIETARY AND CONFIDENTIAL
 THIS INFORMATION IS THE PROPERTY OF BENDPAK INC. AND IS NOT TO BE REPRODUCED OR TRANSMITTED IN ANY FORM OR BY ANY MEANS, ELECTRONIC OR MECHANICAL, INCLUDING PHOTOCOPYING, RECORDING, OR BY ANY INFORMATION STORAGE AND RETRIEVAL SYSTEM.
 BENDPAK INC. 20440 AGOURA RD. AGOURA HILLS, CA 91301

REVISION	
REV	DESCRIPTION
A	PRODUCTION RELEASE, DERIVED FROM 5216195
B	ADDED 5535058 AND 5535059, ASSIGNED PART NUMBER, UPDATED BOM REVISIONS AND NEXT ASSEMBLY

ITEM NO.	PART NUMBER	DESCRIPTION	QTY.
1	5602109	12APF POWER SIDE POST WELDMENT	1
2	5216327	12APF LIFT HEAD ASSEMBLY	1
3	5502066	CYLINDER ASSEMBLY Ø2.5 x 69"	1
4	5701115	CYLINDER CLAMP ASSY 74-79	1
5	5575113	12/16/20AP SHEAVE ASSEMBLY, Ø152mm	2
6	5620142	12/16/20AP CABLE SHEAVE PIN WELDMENT, Ø33mm	2
7	5530181	HHB M6 x 1.0 x 10 FT. CL 10.9	2
8	5530248	HHB M8 x 1.25 x 45 FT. CL 10.9	2
9	5535001	NUT M8 x 1.25 NL, CL 10.9	3
10	5746711	12APF/SRT SHEAVE PLATE SPACER	2
11	5601953	12APF/SRT POWER SIDE SAFETY WELDMENT	1
12	5746494	AP SAFETY PIVOT PIN	1
13	5530414	BHSS M8 x 1.25 x 25 CL 10.9	1
14	5545202	WASHER M8 x Ø15 SL, CL 10.9	1
15	5540047	EXTENSION SPRING Ø6.35 x 38mm	2
16	5530045	BHPS M5 x 0.8 x 10 FT. CL 8.8	4
17	5575074	AP SAFETY CABLE ROLLER	1
18	5563350	SAFETY SHEAVE SPACER, 11.5mm	1
19	5530756	HHB M6 x 1.0 x 25 FT. CL 10.9	1
20	5535357	NUT M6 x 1.0 NL, CL 10.9	1
21	5575325	SAFETY CABLE SHEAVE, Ø50mm	1
22	5530407	BHSS M8 x 1.25 x 40 FT. CL 10.9	1
23	5535057	NUT M8 x 1.25 x 17.5, RIVET	4
24	5535058	NUT M6 x 1.0 x 18, RIVET	4
25	5535059	NUT M10 x 1.5 x 20.5, RIVET	2

WHERE USED
12APF

NOTE: UNLESS OTHERWISE SPECIFIED.
 1. REFER TO MODEL FOR ADDITIONAL INFORMATION
 2. SEE SHIPPING INSTRUCTIONS FOR FINAL PACKAGING ASSEMBLE ITEMS AS SHOWN

DO NOT SCALE DRAWING		NAME	DATE
DRAWN	RK	05/24/2024	
CHECKED			
THIRD ANGLE PROJECTION			
DIMENSIONS ARE IN MM			

PROPRIETARY AND CONFIDENTIAL
 THIS INFORMATION IS THE PROPERTY OF BENDPAK INC. AND IS NOT TO BE REPRODUCED OR TRANSMITTED IN ANY FORM OR BY ANY MEANS, ELECTRONIC OR MECHANICAL, INCLUDING PHOTOCOPYING, RECORDING, OR BY ANY INFORMATION STORAGE AND RETRIEVAL SYSTEM.
 BENDPAK INC. 20440 AGOURA RD. AGOURA HILLS, CA 91301

REVISION	
REV	DESCRIPTION
A	PRODUCTION RELEASE, DERIVED FROM 5216195
B	ADDED 5535058 AND 5535059, ASSIGNED PART NUMBER, UPDATED BOM REVISIONS AND NEXT ASSEMBLY

ITEM NO.	PART NUMBER	DESCRIPTION	QTY.
1	5602109	12APF POWER SIDE POST WELDMENT	1
2	5216327	12APF LIFT HEAD ASSEMBLY	1
3	5502066	CYLINDER ASSEMBLY Ø2.5 x 69"	1
4	5701115	CYLINDER CLAMP ASSY 74-79	1
5	5575113	12/16/20AP SHEAVE ASSEMBLY, Ø152mm	2
6	5620142	12/16/20AP CABLE SHEAVE PIN WELDMENT, Ø33mm	2
7	5530181	HHB M6 x 1.0 x 10 FT. CL 10.9	2
8	5530248	HHB M8 x 1.25 x 45 FT. CL 10.9	2
9	5535001	NUT M8 x 1.25 NL, CL 10.9	3
10	5746711	12APF/SRT SHEAVE PLATE SPACER	2
11	5601953	12APF/SRT POWER SIDE SAFETY WELDMENT	1
12	5746494	AP SAFETY PIVOT PIN	1
13	5530414	BHSS M8 x 1.25 x 25 CL 10.9	1
14	5545202	WASHER M8 x Ø15 SL, CL 10.9	1
15	5540047	EXTENSION SPRING Ø6.35 x 38mm	2
16	5530045	BHPS M5 x 0.8 x 10 FT. CL 8.8	4
17	5575074	AP SAFETY CABLE ROLLER	1
18	5563350	SAFETY SHEAVE SPACER, 11.5mm	1
19	5530756	HHB M6 x 1.0 x 25 FT. CL 10.9	1
20	5535357	NUT M6 x 1.0 NL, CL 10.9	1
21	5575325	SAFETY CABLE SHEAVE, Ø50mm	1
22	5530407	BHSS M8 x 1.25 x 40 FT. CL 10.9	1
23	5535057	NUT M8 x 1.25 x 17.5, RIVET	4
24	5535058	NUT M6 x 1.0 x 18, RIVET	4
25	5535059	NUT M10 x 1.5 x 20.5, RIVET	2

WHERE USED
12APF

NOTE: UNLESS OTHERWISE SPECIFIED.
 1. REFER TO MODEL FOR ADDITIONAL INFORMATION
 2. SEE SHIPPING INSTRUCTIONS FOR FINAL PACKAGING ASSEMBLE ITEMS AS SHOWN

DO NOT SCALE DRAWING		NAME	DATE
DRAWN	RK	05/24/2024	
CHECKED			
THIRD ANGLE PROJECTION			
DIMENSIONS ARE IN MM			

PROPRIETARY AND CONFIDENTIAL
 THIS INFORMATION IS THE PROPERTY OF BENDPAK INC. AND IS NOT TO BE REPRODUCED OR TRANSMITTED IN ANY FORM OR BY ANY MEANS, ELECTRONIC OR MECHANICAL, INCLUDING PHOTOCOPYING, RECORDING, OR BY ANY INFORMATION STORAGE AND RETRIEVAL SYSTEM.
 BENDPAK INC. 20440 AGOURA RD. AGOURA HILLS, CA 91301

REVISION	
REV	DESCRIPTION
A	PRODUCTION RELEASE, DERIVED FROM 5216195
B	ADDED 5535058 AND 5535059, ASSIGNED PART NUMBER, UPDATED BOM REVISIONS AND NEXT ASSEMBLY

ITEM NO.	PART NUMBER	DESCRIPTION	QTY.
1	5602109	12APF POWER SIDE POST WELDMENT	1
2	5216327	12APF LIFT HEAD ASSEMBLY	1
3	5502066	CYLINDER ASSEMBLY Ø2.5 x 69"	1
4	5701115	CYLINDER CLAMP ASSY 74-79	1
5	5575113	12/16/20AP SHEAVE ASSEMBLY, Ø152mm	2
6	5620142	12/16/20AP CABLE SHEAVE PIN WELDMENT, Ø33mm	2
7	5530181	HHB M6 x 1.0 x 10 FT. CL 10.9	2
8	5530248	HHB M8 x 1.25 x 45 FT. CL 10.9	2
9	5535001	NUT M8 x 1.25 NL, CL 10.9	3
10	5746711	12APF/SRT SHEAVE PLATE SPACER	2
11	5601953	12APF/SRT POWER SIDE SAFETY WELDMENT	1
12	5746494	AP SAFETY PIVOT PIN	1
13	5530414	BHSS M8 x 1.25 x 25 CL 10.9	1
14	5545202	WASHER M8 x Ø15 SL, CL 10.9	1
15	5540047	EXTENSION SPRING Ø6.35 x 38mm	2
16	5530045	BHPS M5 x 0.8 x 10 FT. CL 8.8	4
17	5575074	AP SAFETY CABLE ROLLER	1
18	5563350	SAFETY SHEAVE SPACER, 11.5mm	1
19	5530756	HHB M6 x 1.0 x 25 FT. CL 10.9	1
20	5535357	NUT M6 x 1.0 NL, CL 10.9	1
21	5575325	SAFETY CABLE SHEAVE, Ø50mm	1
22	5530407	BHSS M8 x 1.25 x 40 FT. CL 10.9	1
23	5535057	NUT M8 x 1.25 x 17.5, RIVET	4
24	5535058	NUT M6 x 1.0 x 18, RIVET	4
25	5535059	NUT M10 x 1.5 x 20.5, RIVET	2

WHERE USED
12APF

NOTE: UNLESS OTHERWISE SPECIFIED.
 1. REFER TO MODEL FOR ADDITIONAL INFORMATION
 2. SEE SHIPPING INSTRUCTIONS FOR FINAL PACKAGING ASSEMBLE ITEMS AS SHOWN

DO NOT SCALE DRAWING		NAME	DATE
DRAWN	RK	05/24/2024	
CHECKED			
THIRD ANGLE PROJECTION			
DIMENSIONS ARE IN MM			

PROPRIETARY AND CONFIDENTIAL
 THIS INFORMATION IS THE PROPERTY OF BENDPAK INC. AND IS NOT TO BE REPRODUCED OR TRANSMITTED IN ANY FORM OR BY ANY MEANS, ELECTRONIC OR MECHANICAL, INCLUDING PHOTOCOPYING, RECORDING, OR BY ANY INFORMATION STORAGE AND RETRIEVAL SYSTEM.
 BENDPAK INC. 20440 AGOURA RD. AGOURA HILLS, CA 91301

REVISION	
REV	DESCRIPTION
A	PRODUCTION RELEASE, DERIVED FROM 5216195
B	ADDED 5535058 AND 5535059, ASSIGNED PART NUMBER, UPDATED BOM REVISIONS AND NEXT ASSEMBLY

ITEM NO.	PART NUMBER	DESCRIPTION	QTY.
1	5602109	12APF POWER SIDE POST WELDMENT	1
2	5216327	12APF LIFT HEAD ASSEMBLY	1
3	5502066	CYLINDER ASSEMBLY Ø2.5 x 69"	1
4	5701115	CYLINDER CLAMP ASSY 74-79	1
5	5575113	12/16/20AP SHEAVE ASSEMBLY, Ø152mm	2
6	5620142	12/16/20AP CABLE SHEAVE PIN WELDMENT, Ø33mm	2
7	5530181	HHB M6 x 1.0 x 10 FT. CL 10.9	2
8	5530248	HHB M8 x 1.25 x 45 FT. CL 10.9	2
9	5535001	NUT M8 x 1.25 NL, CL 10.9	3
10	5746711	12APF/SRT SHEAVE PLATE SPACER	2
11	5601953	12APF/SRT POWER SIDE SAFETY WELDMENT	1
12	5746494	AP SAFETY PIVOT PIN	1
13	5530414	BHSS M8 x 1.25 x 25 CL 10.9	1
14	5545202	WASHER M8 x Ø15 SL, CL 10.9	1
15	5540047	EXTENSION SPRING Ø6.35 x 38mm	2
16	5530045	BHPS M5 x 0.8 x 10 FT. CL 8.8	4
17	5575074	AP SAFETY CABLE ROLLER	1
18	5563350	SAFETY SHEAVE SPACER, 11.5mm	1
19	5530756	HHB M6 x 1.0 x 25 FT. CL 10.9	1
20	5535357	NUT M6 x 1.0 NL, CL 10.9	1
21	5575325	SAFETY CABLE SHEAVE, Ø50mm	1
22	5530407	BHSS M8 x 1.25 x 40 FT. CL 10.9	1
23	5535057	NUT M8 x 1.25 x 17.5, RIVET	4
24	5535058	NUT M6 x 1.0 x 18, RIVET	4
25	5535059	NUT M10 x 1.5 x 20.5, RIVET	2

WHERE USED
12APF

NOTE: UNLESS OTHERWISE SPECIFIED.
 1. REFER TO MODEL FOR ADDITIONAL INFORMATION
 2. SEE SHIPPING INSTRUCTIONS FOR FINAL PACKAGING ASSEMBLE ITEMS AS SHOWN

DO NOT SCALE DRAWING		NAME	DATE
DRAWN	RK	05/24/2024	
CHECKED			
THIRD ANGLE PROJECTION			
DIMENSIONS ARE IN MM			

PROPRIETARY AND CONFIDENTIAL
 THIS INFORMATION IS THE PROPERTY OF BENDPAK INC. AND IS NOT TO BE REPRODUCED OR TRANSMITTED IN ANY FORM OR BY ANY MEANS, ELECTRONIC OR MECHANICAL, INCLUDING PHOTOCOPYING, RECORDING, OR BY ANY INFORMATION STORAGE AND RETRIEVAL SYSTEM.
 BENDPAK INC. 20440 AGOURA RD. AGOURA HILLS, CA 91301

REVISION	
REV	DESCRIPTION
A	PRODUCTION RELEASE, DERIVED FROM 5216195
B	ADDED 5535058 AND 5535059, ASSIGNED PART NUMBER, UPDATED BOM REVISIONS AND NEXT ASSEMBLY

ITEM NO.	PART NUMBER	DESCRIPTION	QTY.
1	5602109	12APF POWER SIDE POST WELDMENT	1
2	5216327	12APF LIFT HEAD ASSEMBLY	1
3	5502066	CYLINDER ASSEMBLY Ø2.5 x 69"	1
4	5701115	CYLINDER CLAMP ASSY 74-79	1
5	5575113	12/16/20AP SHEAVE ASSEMBLY, Ø152mm	2
6	5620142	12/16/20AP CABLE SHEAVE PIN WELDMENT, Ø33mm	2
7	5530181	HHB M6 x 1.0 x 10 FT. CL 10.9	2
8	5530248	HHB M8 x 1.25 x 45 FT. CL 10.9	2
9	5535001	NUT M8 x 1.25 NL, CL 10.9	3
10	5746711	12APF/SRT SHEAVE PLATE SPACER	2
11	5601953	12APF/SRT POWER SIDE SAFETY WELDMENT	1
12	5746494	AP SAFETY PIVOT PIN	1
13	5530414	BHSS M8 x 1.25 x 25 CL 10.9	1
14	5545202	WASHER M8 x Ø15 SL, CL 10.9	1
15	5540047	EXTENSION SPRING Ø6.35 x 38mm	2
16	5530045	BHPS M5 x 0.8 x 10 FT. CL 8.8	4
17	5575074	AP SAFETY CABLE ROLLER	1
18	5563350	SAFETY SHEAVE SPACER, 11.5mm	1
19	5530756	HHB M6 x 1.0 x 25 FT. CL 10.9	1
20	5535357	NUT M6 x 1.0 NL, CL 10.9	1
21	5575325	SAFETY CABLE SHEAVE, Ø50mm	1
22	5530407	BHSS M8 x 1.25 x 40 FT. CL 10.9	1
23	5535057	NUT M8 x 1.25 x 17.5, RIVET	4
24	5535058	NUT M6 x 1.0 x 18, RIVET	4
25	5535059	NUT M10 x 1.5 x 20.5, RIVET	2

WHERE USED
12APF

NOTE: UNLESS OTHERWISE SPECIFIED.
 1. REFER TO MODEL FOR ADDITIONAL INFORMATION
 2. SEE SHIPPING INSTRUCTIONS FOR FINAL PACKAGING ASSEMBLE ITEMS AS SHOWN

DO NOT SCALE DRAWING		NAME	DATE
DRAWN	RK	05/24/2024	
CHECKED			
THIRD ANGLE PROJECTION			
DIMENSIONS ARE IN MM			

PROPRIETARY AND CONFIDENTIAL
 THIS INFORMATION IS THE PROPERTY OF BENDPAK INC. AND IS NOT TO BE REPRODUCED OR TRANSMITTED IN ANY FORM OR BY ANY MEANS, ELECTRONIC OR MECHANICAL, INCLUDING PHOTOCOPYING, RECORDING, OR BY ANY INFORMATION STORAGE AND RETRIEVAL SYSTEM.
 BENDPAK INC. 20440 AGOURA RD. AGOURA HILLS, CA 91301

REVISION	
REV	DESCRIPTION
A	PRODUCTION RELEASE, DERIVED FROM 5216195
B	ADDED 5535058 AND 5535059, ASSIGNED PART NUMBER, UPDATED BOM REVISIONS AND NEXT ASSEMBLY

ITEM NO.	PART NUMBER	DESCRIPTION	QTY.
1	5602109	12APF POWER SIDE POST WELDMENT	1
2	5216327	12APF LIFT HEAD ASSEMBLY	1
3	5502066	C	

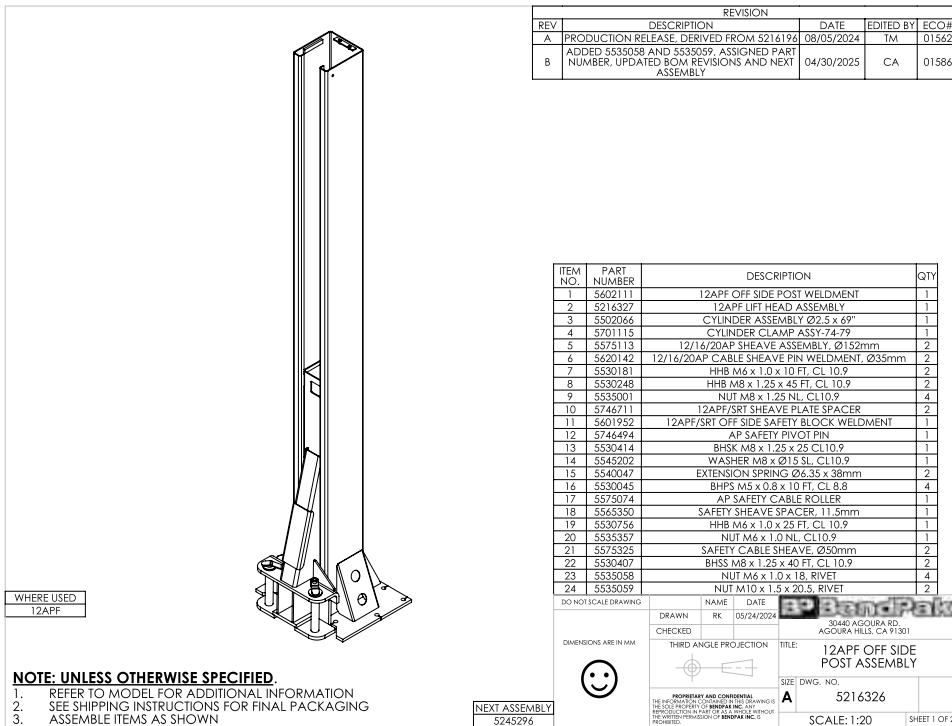
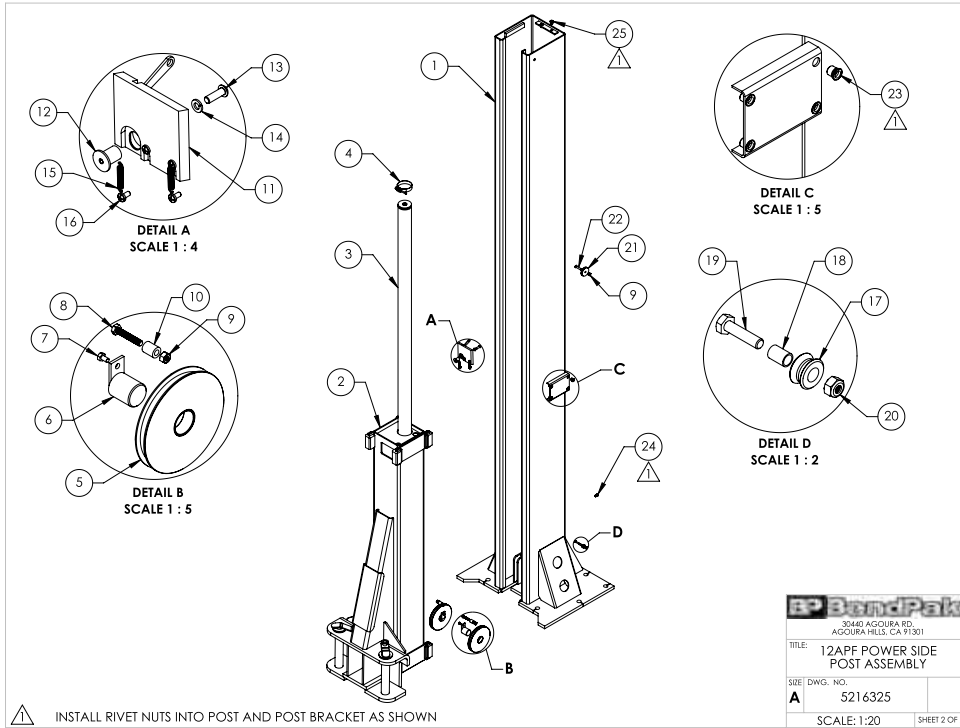

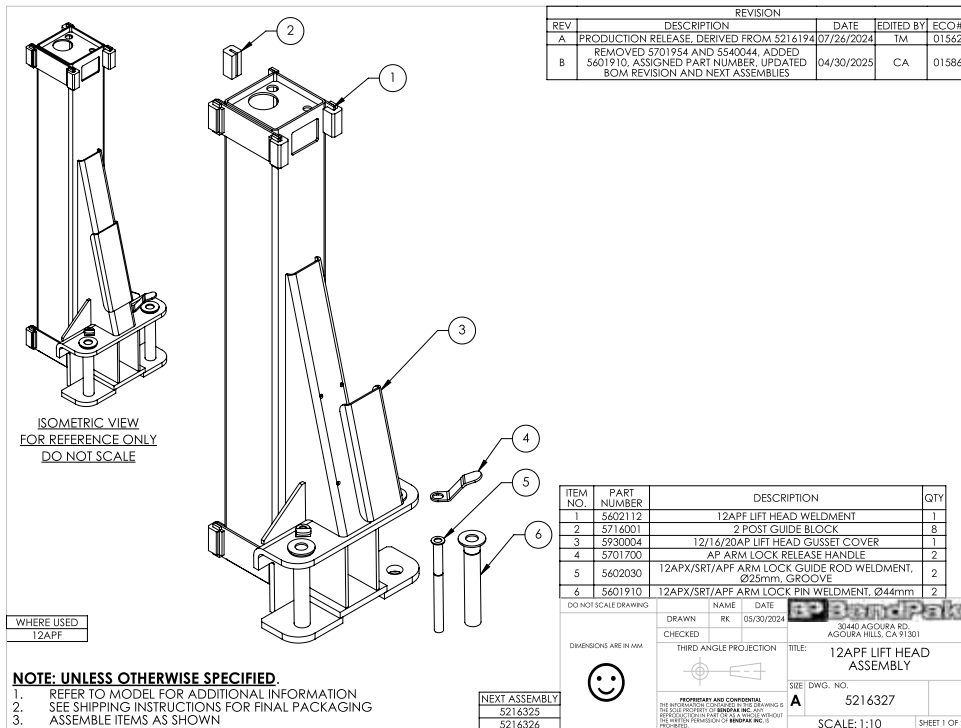
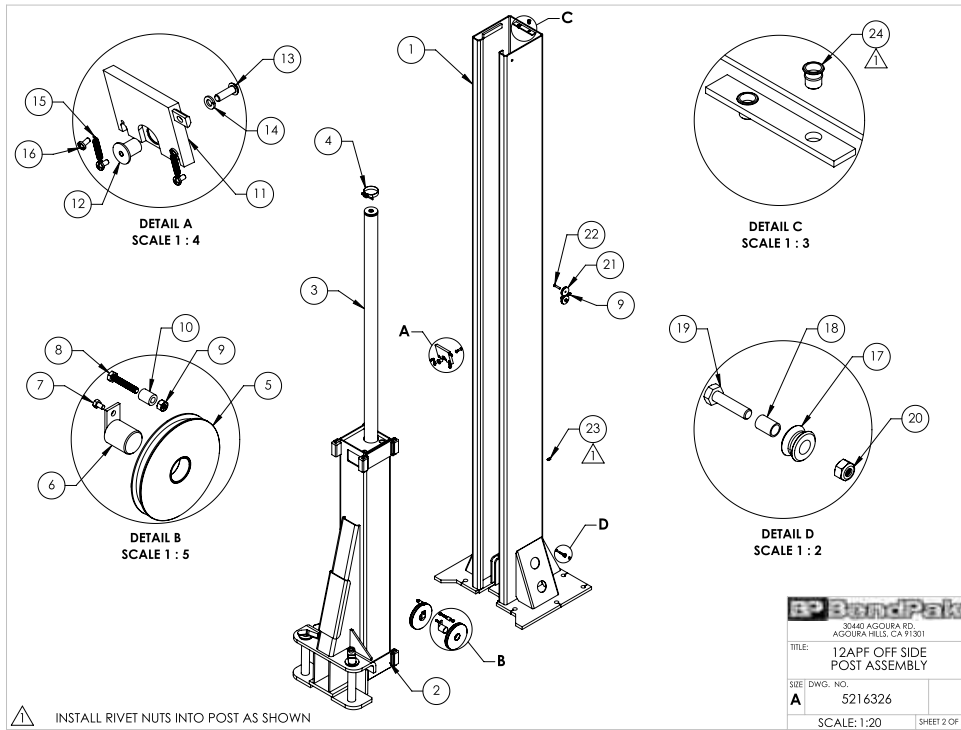

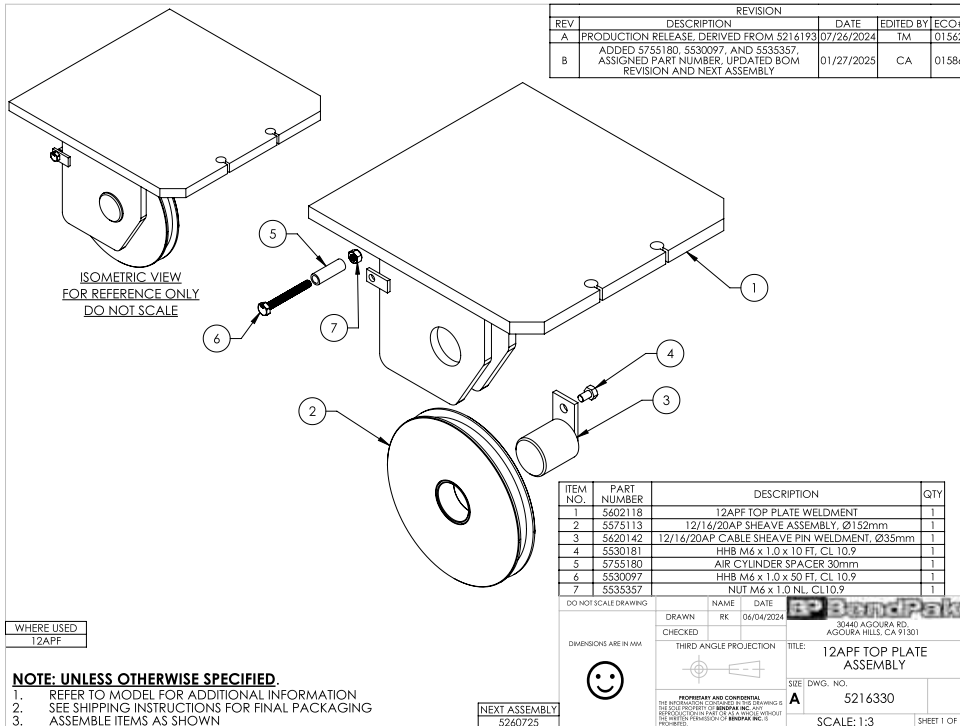
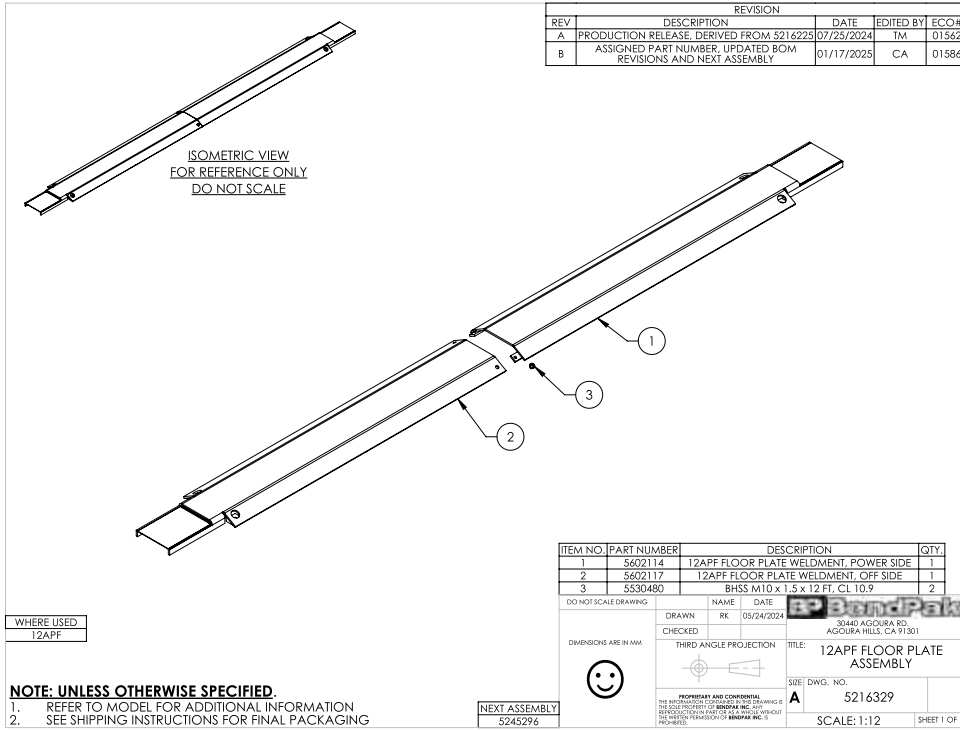

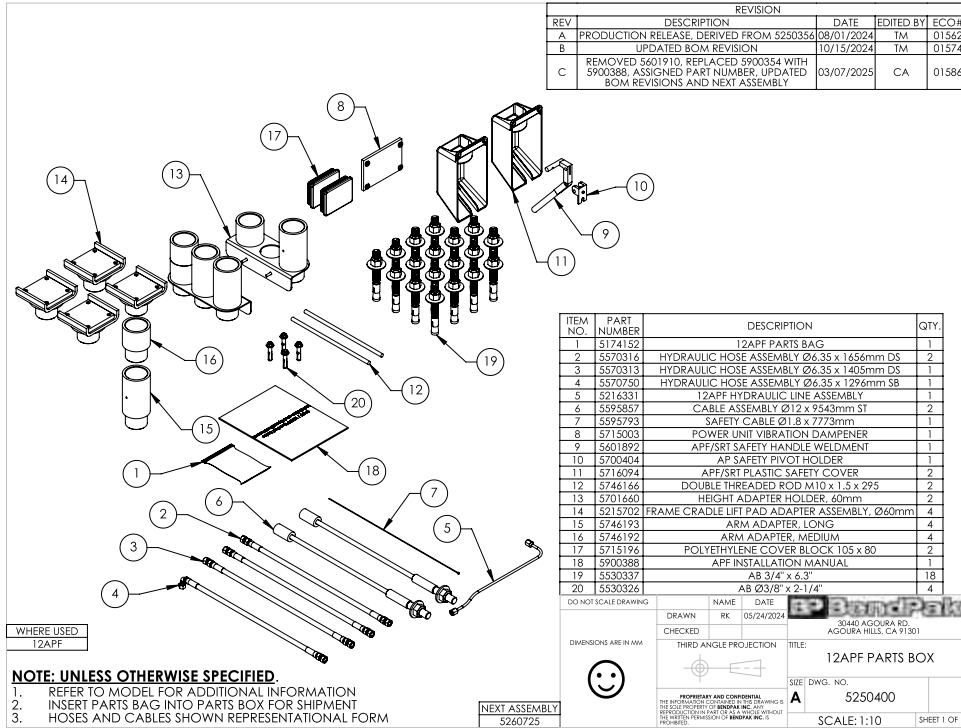

REVISION					
REV	DESCRIPTION	DATE	EDITED BY	ECO#	
A	PRODUCTION RELEASE, DERIVED FROM 5250354	08/01/2024	TM	01562	
B	UPDATED BOM REVISION	10/15/2024	TM	01574	
C	REMOVED 5601910, REPLACED 5900354 WITH 5900388 ASSIGNED PART NUMBER. UPDATED BOM REVISIONS AND NEXT ASSEMBLY	03/07/2025	CA	01586	

ITEM NO.	PART NUMBER	DESCRIPTION	QTY.
1	5174152	12APF PARTS BAG	1
2	5570316	HYDRAULIC HOSE ASSEMBLY Ø6.35 x 1656mm DS	2
3	5570313	HYDRAULIC HOSE ASSEMBLY Ø6.35 x 1405mm DS	1
4	5570750	HYDRAULIC HOSE ASSEMBLY Ø6.35 x 1296mm SB	1
5	5216331	12APF HYDRAULIC LINE ASSEMBLY	1
6	5595857	CABLE ASSEMBLY Ø12 x 9543mm ST	2
7	5595793	SAFETY CABLE Ø1.8 x 7773mm	1
8	5715003	POWER UNIT VIBRATION DAMPENER	1
9	5601892	APF/SRT SAFETY HANDLE WELDMENT	1
10	5700404	AP SAFETY RIVOT HOLDER	1
11	5716094	APF/SRT PLASTIC SAFETY COVER	2
12	5746166	DOUBLE THREADED ROD M10 x 1.5 x 295	2
13	5701660	HEIGHT ADAPTER HOLDER, 60mm	2
14	5215702	FRAME CRADLE LIFT PAD ADAPTER ASSEMBLY, Ø60mm	4
15	5746193	ARM ADAPTER, LONG	4
16	5746192	ARM ADAPTER, MEDIUM	4
17	5715196	POLYETHYLENE COVER BLOCK, 105 x 80	2
18	5900388	APF INSTALLATION MANUAL	1
19	5530337	AB 3/4" x 6.3"	18
20	5530326	AB Ø3/8" x 2-1/4"	4

WHERE USED
12APF

- NOTE: UNLESS OTHERWISE SPECIFIED.**
1. REFER TO MODEL FOR ADDITIONAL INFORMATION
 2. INSERT PARTS BAG INTO PARTS BOX FOR SHIPMENT
 3. HOSES AND CABLES SHOWN REPRESENTATIONAL FORM

NEXT ASSEMBLY
5260725

DO NOT SCALE DRAWING

DRAWN	NAME	DATE
CHKD	RK	05/24/2024
CHECKED		
THIRD ANGLE PROJECTION	TITLE:	12APF PARTS BOX
	SHEET DWGS. NO.	A 5250400
	SCALE:	1:10
		SHEET 1 OF 1

30440 AGOURA RD.
AGOURA HILLS, CA 91301

PROPRIETARY AND CONFIDENTIAL
THIS DOCUMENT IS THE PROPERTY OF BENDPAK, INC. AND IS TO BE USED ONLY FOR THE PROJECT AND QUANTITY SPECIFIED HEREIN. NO REPRODUCTION OR TRANSMISSION OF BENDPAK, INC.'S INFORMATION IS PERMITTED.

Automotive Lift Institute (ALI) Store

You probably checked the [ALI's Directory of Certified Lifts](http://www.autolift.org/ali-directory-of-certified-lifts/) (www.autolift.org/ali-directory-of-certified-lifts/) before making your most recent Lift purchase, but did you know the [ALI Store](http://www.autolift.org/ali-store/) (www.autolift.org/ali-store/) offers a wide variety of professional, easy-to-use, and reasonably priced



Car Lift Safety Materials Value Pack

Everything you need to Keep Lift Safety First At the top and at car lift owners

\$65.00



Vehicle Lifting Points Guide (2024)

Quickly Find Car and Truck Lifting Points Anytime with New Electronic Guide If you're using

\$15.00 – \$24.00



Lifting It Right Online Training

Learn to Stay Safe in the Bay

The number one reason cars fall



Lifting It Right Safety Manual

More than 4 million sold Completely updated and expanded second edition of the world's best-selling

\$18.00 – \$27.00



ALI Automotive Lift Safety Tips Card (10 pack)

Keep Lift Safety in View When it comes to car lift safety, track the deck.

\$20.00



Automotive Lift Safety Tips Poster

Eye-Catching Poster Helps keep focus on Lift Safety help reinforce your car lift safety message

\$22.00



ANSI/ALI ALDIM: 2020 Standard for Automotive Lifts - Safety Requirements for Operation, Inspection and Maintenance

Lift Safety Standard Covering Lift Use, Inspection and Maintenance ANSI/ALI ALDIM Safety Requirements for Operation

\$20.00 – \$29.00

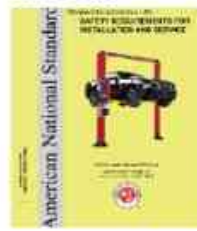

ANSI/ALI ALIS: 2022 Standard for Automotive Lifts - Safety Requirements for Installation and Service

American National Safety Standard Governing Lift Installation and Service throughout North America Car lift safety

\$15.00 – \$22.00

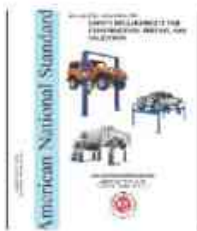

ANSI/ALI ALCTV: 2017 Standard for Automotive Lifts - Safety Requirements for Construction, Testing, and Validation

The Accepted Lift Safety and Performance Standard in North America ANSI/ALI ALCTV: 2017 Safety Requirements



Replacement Warning Label Kit

North America's recognized vehicle lift safety and performance standard, ANSI/ALI ALCTV: 2017 Safety Requirements for

\$60.85



ALI Lift Inspector Certification Program Registration

Become an ALI Certified Lift Inspector ALI's Lift Inspector Certification Program is the only program

\$2,100.00



KPA Online Training Subscription

On-Line Car Dealer Training from our Safety Partner KPA This is a KPA product. ALI

\$1,200.00

training and safety materials that will make your garage a safer place to work?

The ALI Store is your trusted source for workplace safety!

Visit today and get the training and materials you need to work safely:

www.autolift.org/ali-store/.



30440 Agoura Rd.
Agoura Hills, CA 91301 USA

© 2025 by BendPak Inc. All rights reserved.

bendpak.com