

Clear Floor Two-Post Lift Installation and Operation Manual

Manual P/N 5900593 — Revision A1 — November 2025

Model:

- AL10C



*Original instructions in
the English language*

DANGER

IMPORTANT Safety Instructions, save these instructions! Read the *entire* contents of this manual *before* using this product. Failure to follow the instructions and safety precautions in this manual can result in severe injury or death. Make sure all other operators also read this manual. Keep the manual near the product for future reference. *By proceeding with setup and operation, you agree that you fully understand the contents of this manual and assume full responsibility for product use.*

Manual. AL10C Two-Post Lift, *Installation and Operation Manual*, Part Number 5900593, Revision A1, released November 2025.

Copyright. Copyright © 2025 by BendPak Inc. All rights reserved. Copies of this document can be made if it is agreed that: full attribution goes to BendPak Inc., changes to the content is not authorized, no rights are gained to any of the content, and copies will not be used for commercial purposes.

Trademarks. APEX and the APEX logo are registered trademarks of BendPak Inc. All other company, product and service names are used for identification only. All trademarks and registered trademarks mentioned in this manual are the property of their respective owners.

Limitations. Every effort has been made to ensure that complete and accurate instructions are included in this manual. However, product updates, revisions, and/or changes may have occurred since this manual was published. BendPak reserves the right to change any information in this manual without incurring any obligation for equipment previously or subsequently sold. All drawings are for reference only; do not scale. BendPak is not responsible for typographical errors in this manual. The latest version of this **manual for the AL10C can be found on the BendPak website.**



Warranty. The BendPak warranty is a commitment to the quality and value of this product. Contact the nearest BendPak dealer or visit www.bendpak.com/support/warranty for full warranty details.

Safety. The AL10C Lift was designed and manufactured with safety in mind. Installer and operator safety depends on proper training and thoughtful operation. Do not set up, operate, maintain, or repair the Lift without reading and understanding this manual and the labels on the unit. **Do not use the Lift unless it can be done so safely!**

Owner Responsibility. To properly maintain the Lift and ensure the operator's safety, it is the responsibility of the product owner to read and follow the following:

- Follow all installation, operation, and maintenance instructions.
- Make sure the installation of the Lift conforms to all applicable local, state, and federal codes, rules, and regulations, such as state and federal OSHA regulations and electrical codes.
- Read and follow all safety instructions. Keep them readily available for installers and operators.
- Make sure all operators are properly trained on the safe operation of the unit and are properly supervised.
- Do not operate the product until it is confirmed that all parts are securely in place and operating correctly.
- Carefully inspect the product on a regular basis and perform all repairs and maintenance as required.
- Service and maintain the unit using only approved replacement parts.
- Keep the manual with the product and make sure all labels are clean and visible.
- **BendPak** makes no promises, guarantees or assurances that our products meet any state, county, federal or international mandated permits, licenses, codes, standards, certifications, or any other mandates other than what is listed or shown on the BendPak website(s), or any BendPak or APEX online or published catalog. Not all BendPak Lift models meet the standards as prescribed by ANSI/ALI ALCTV-(current edition) or ANSI/UL 201. Consult www.autolift.org for a complete list of Lift models that meet ANSI/ALI ALCTV-(current edition) or ANSI/UL 201 or contact BendPak via sales@bendpak.com. **Buyer assumes full responsibility for any state, county, federal or international mandated permits, licenses, codes, standards, certifications, or any other mandates required related to the installation and/or operation of any BendPak product.** BendPak will not be responsible for any charges, fines, liens, or other levies imposed on the Buyer related to any special or regional structural, seismic or any other building code and/or codes such as the Uniform Building Code (UBC), International Building Code (IBC), or any other state, county, federal or international mandated permit, license, code, standard, certification, or other mandate, law, rule, regulation or directive by any other agency, government, administrations, or corporations whether state, county, federal, or international mandated.

Only operate the Lift if it can be used safely!

Unit Information. Enter the Model Number, Serial Number, and the Date of Manufacture from the ID label on the unit. This information is required for part or warranty issues.

Model Number: _____

Serial Number: _____

Date of Manufacture: _____

Designed and engineered by BendPak Inc. in Southern California, USA. Made in China.

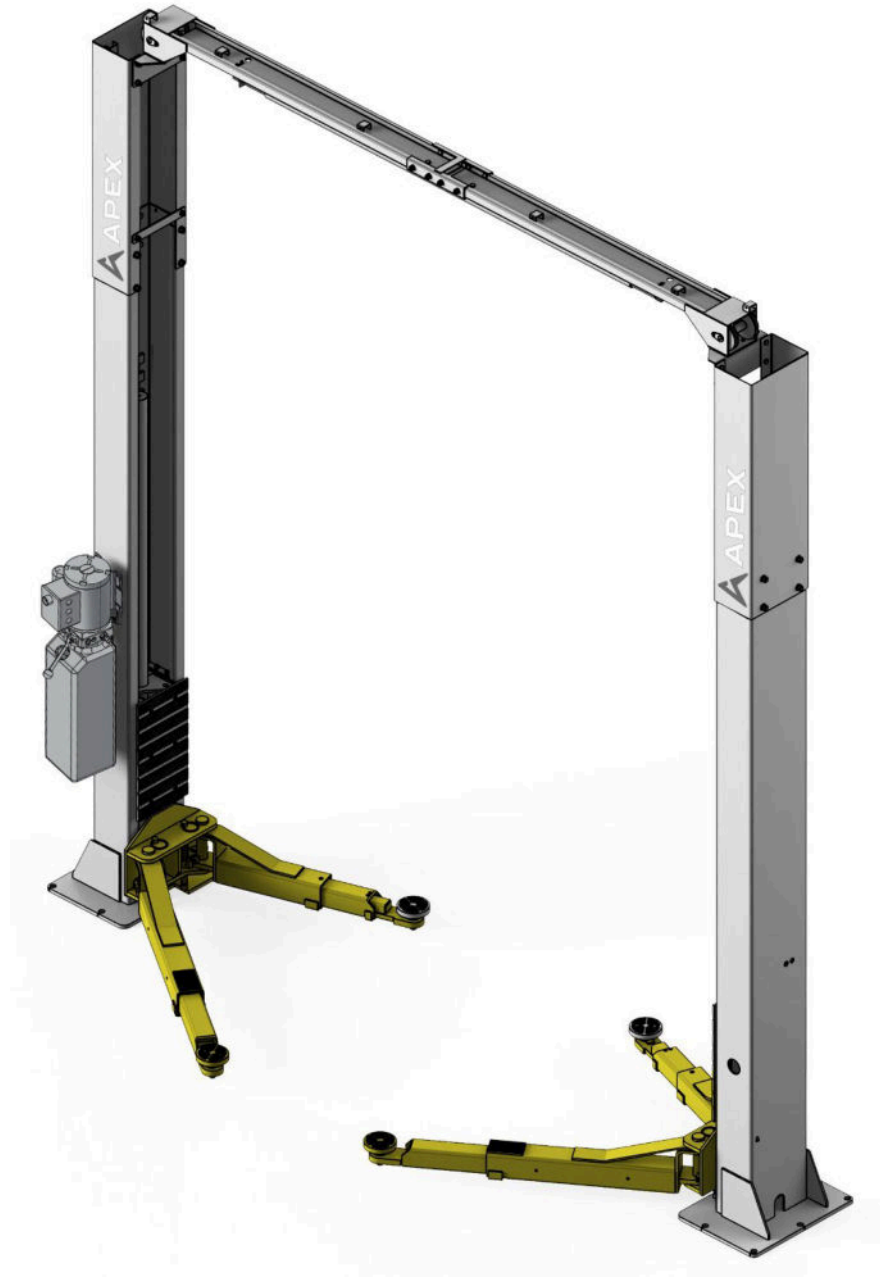

Table of Contents

Introduction	4	Maintenance	60
Shipping Information	5	Troubleshooting	69
Safety Considerations	5	Wiring Diagrams.....	71
Components	9	Labels	73
Specifications.....	10	Parts	76
Installation Checklist	12	ALI Store	81
Installation	13	Maintenance Log.....	82
Operation	51		

Introduction

This manual describes the **APEX AL10C**, a two-post Lift with an overall height of 148 in. (3,759 mm) and capable of lifting vehicles up to 10,000 lbs. (4,536 kg).

⚠ DANGER Be very careful when installing, operating, maintaining, or repairing this equipment. Failure to do so could result in property or product damage, injury, or (in very rare cases) death. Make sure only authorized personnel operate this equipment. All repairs must be performed by an authorized technician. Do not make modifications to the unit as this will void the warranty and increase the chance of injury or property damage. Make sure to read and follow the instructions on the labels on the unit.

This manual is mandatory reading for all users of the AL10C Two-Post Lift, including anyone who installs, operates, maintains, or repairs them. Always keep this manual on or near the Lift.

Technical support and service is available from the dealer, on the web at bendpak.com/support, by email at support@bendpak.com, or by phone at **(888) 856-5820**.

Online chat is also available at www.bendpak.com. Click the chat icon for support. 

Shipping Information

This equipment was carefully checked before shipping. Nevertheless, the shipment should be thoroughly inspected **before** signing to acknowledge that it has been received.

Signing the bill of lading tells the carrier that the items on the invoice were received in good condition. **Do not sign the bill of lading until after the shipment has been inspected.** If any of the items listed on the bill of lading are missing or damaged, do not accept the shipment until the carrier makes a notation on the bill of lading that lists the missing or damaged goods.

If missing or damaged goods are discovered **after** receiving the shipment and the bill of lading has been signed, notify the carrier at once and request that the carrier perform an inspection. If the carrier will not perform an inspection, prepare a signed statement to the effect that the carrier has been notified (on a specific date), and that the carrier has failed to comply with the request.

It is difficult to collect for loss or damage after giving the carrier a signed bill of lading. If this happens, file a claim with the carrier promptly. Support the claim with copies of the bill of lading, freight bill, invoice, and photographs, if available. Our willingness to assist in helping to process the claim does not make us responsible for the collection of claims or replacement of lost or damaged materials.

Safety Considerations

Read this entire manual carefully before using the AL10C Lift. Do not install or operate the Lift until all installation and operating instructions and warnings are clearly understood. Do not allow anyone else to operate the Lift until they are familiar with all operating instructions and warnings.

 **WARNING** **California Proposition 65.** This product can expose installers and operators to chemicals, including styrene and vinyl chloride, which are on the list of over 900 chemicals identified by the State of California to cause cancer, birth defects or reproductive harm. Always use this product in accordance with BendPak's instructions. For more information, visit www.p65warnings.ca.gov.

 **WARNING** BendPak Does not supply hydraulic fluid or lubricants with the Lift. **Always** refer to the Material Safety Data Sheet (MSDS) for safe handling and disposal information. MSDS are available from the hydraulic fluid or lubricant's supplier or manufacturer.

Important Safety Information

When using this equipment, the following basic safety precautions must be followed:

1. Read all instructions and use the Lift only as described in this manual.
2. Only operate the AL10C Lift between temperatures of 41°F to 104°F (5°C to 40°C).
3. Make sure all operators read and understand this *Installation and Operation Manual*. **Keep the manual near the Lift at all times.**
4. For more information about safely installing, using, and servicing the AL10C Lift, BendPak recommends referring to the ANSI/ALI ALIS Standard *Safety Requirements for Installation and Service*.
5. The Lift should only be operated by authorized personnel. Keep children and untrained personnel away from the Lift.

-
6. Do not make any modifications to the Lift as this will void the warranty and increase the chance of injury or property damage. Use only factory-approved attachments or accessories.
 7. Do not use the Lift while tired or under the influence of drugs, alcohol, or medication.
 8. Do not touch hot parts, as this could cause severe burns. Use care when handling the equipment.
 9. Do not operate the Lift if there is a damaged cord, or any part of the equipment has been dropped or damaged – until a qualified service person has examined it and determined that it is safe to use.
 10. Do not let any electrical power cords hang over the edge of a table, bench or counter, or come in contact with hot manifolds or moving fan blades. Loop the power cord securely around the equipment when storing.
 11. If an extension cord is necessary, one with a current rating equal to or greater than that of the equipment should be used. Cords rated for less current than the equipment may overheat. Care should be taken to arrange any cords so that they will not be tripped over or pulled out.
 12. Always unplug the equipment from electrical outlets when not in use. Never use the cord to pull the plug from the outlet. Grasp the plug itself and pull to disconnect.
 13. To reduce the risk of a fire, do not operate the equipment in the vicinity of open containers of flammable liquids (such as gasoline).
 14. Adequate ventilation must be provided when working on operating internal combustion engines.
 15. Keep hair, loose clothing, jewelry, fingers, and all parts of the body away from moving parts.
 16. To reduce the risk of electric shock, do not use the Lift on wet surfaces or expose it to rain.
 17. **Always wear safety glasses!** Everyday glasses only have impact resistant lenses and are not safety glasses.
 18. The AL10C is a two-post service lift. **Use it only for its intended purpose.**
 19. All operators of the Lift must wear OSHA-approved (publication 3151) personal protective equipment **at all times** when installing, using, maintaining, or repairing the Lift. Leather gloves, steel-toed work boots, eye protection, back belts, and hearing protection are all **mandatory**.
 20. **Never** attempt to exceed the rated capacity of the Lift.
 21. Keep loads balanced on the Lift Arm Assemblies. Clear the area immediately if a vehicle is in danger of falling off the Lift.
 22. Modifications to the Lift void the warranty and increase the chance of injury or property damage. **Do not modify any safety-related features in any way.**
 23. The Lift uses electrical energy. If the shop or organization has lockout/tagout policies, make sure to implement them after connecting the Lift to a power source.
 24. When handling the hydraulic components, **always wear safety gloves!** In rare cases, a needle-like stream of hydraulic fluid (even at low pressure) can penetrate fingers, hands, or arms. Such a puncture can feel like a bite, electric shock, or a prick. While it may seem like a minor issue, any amount of hydraulic fluid injected into the human body is a serious issue. Anyone encountering such a puncture wound should be **immediately** taken to the hospital—as an emergency precaution—to determine the extent of the injury. Explain the circumstances of the injury to the attending physician, including what type of hydraulic fluid was involved. Do not assume a puncture wound that could have been caused by hydraulic fluid is a minor issue; it could be life-threatening.
 25. Make a visual inspection of the Lift before using it. Do not use the Lift if any missing or damaged parts are found. Instead, take the Lift out of service and contact an authorized repair facility, the distributor, BendPak at **(888) 856-5820** (follow prompts), or email support@bendpak.com.

26. BendPak recommends making a **thorough** inspection of the Lift at least once a year. Replace any damaged or severely worn parts, decals, or warning labels.



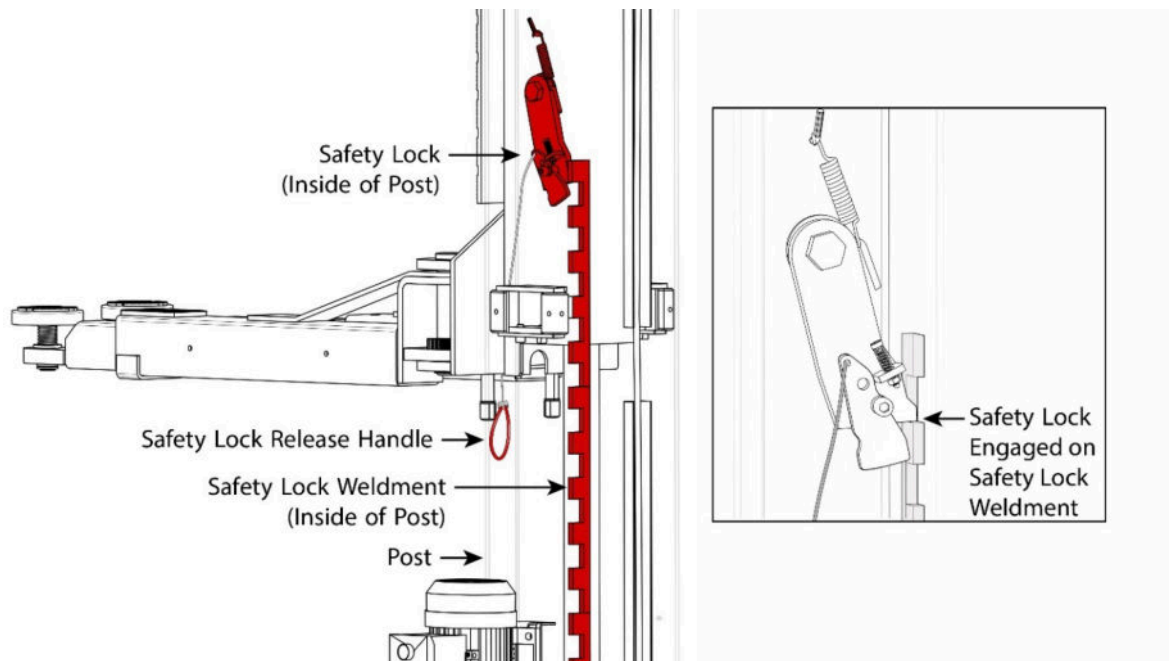

27. Understand Safety Locks and how they work.

- Safety Lock positions are created by the Safety Lock Weldments, which are located on the inside of each Post. As the Lift rises the spring-loaded Safety Locks hit the Safety Lock Weldments, creating a “thumping” sound. The Safety Locks are fully engaged when they are securely lowered onto a Safety Lock Weldment, as shown in the illustration below.
- For more information on Safety Locks, see page 59.



Symbols

The following symbols are used in this manual:

-  **DANGER** Calls attention to a hazard that **will** result in death or injury.
-  **DANGER** Calls attention to an electrical hazard that **will** result in death or injury.
-  **WARNING** Calls attention to a hazard or unsafe practice that **could** result in death or injury.
-  **CAUTION** Calls attention to a hazard or unsafe practice that could result in personal injury, product or property damage.
- NOTICE** Calls attention to a situation that could result in product or property damage.

Liability Information

BendPak assumes **no** liability for damages resulting from:

- Use of the equipment for purposes other than those described in this manual.
- Modifications to the equipment without prior, written permission from BendPak.
- Injury or death caused by modifying, disabling, overriding, or removing safety features.
- Damage to the equipment from external influences.
- Incorrect operation of the equipment.

Components

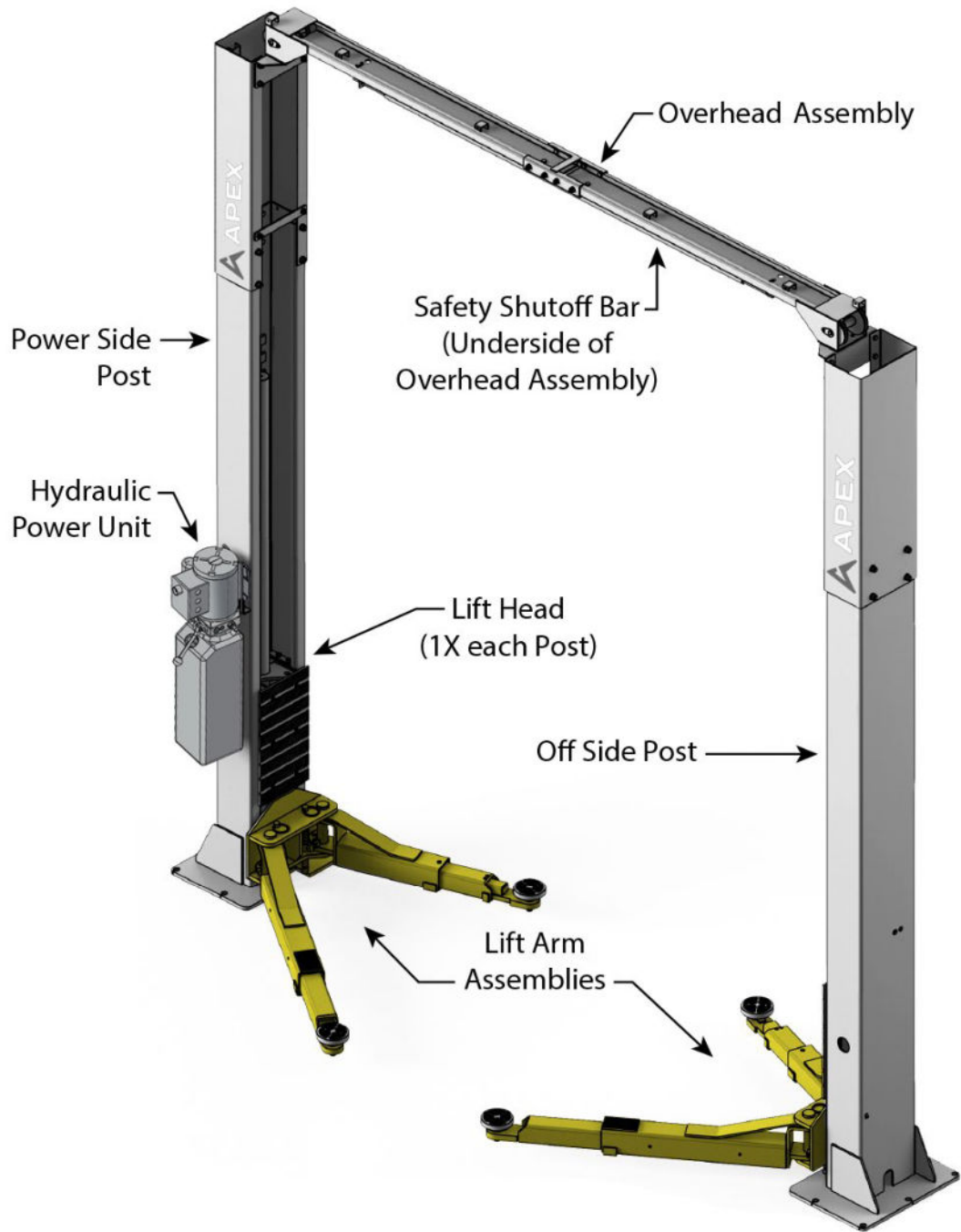

Specifications

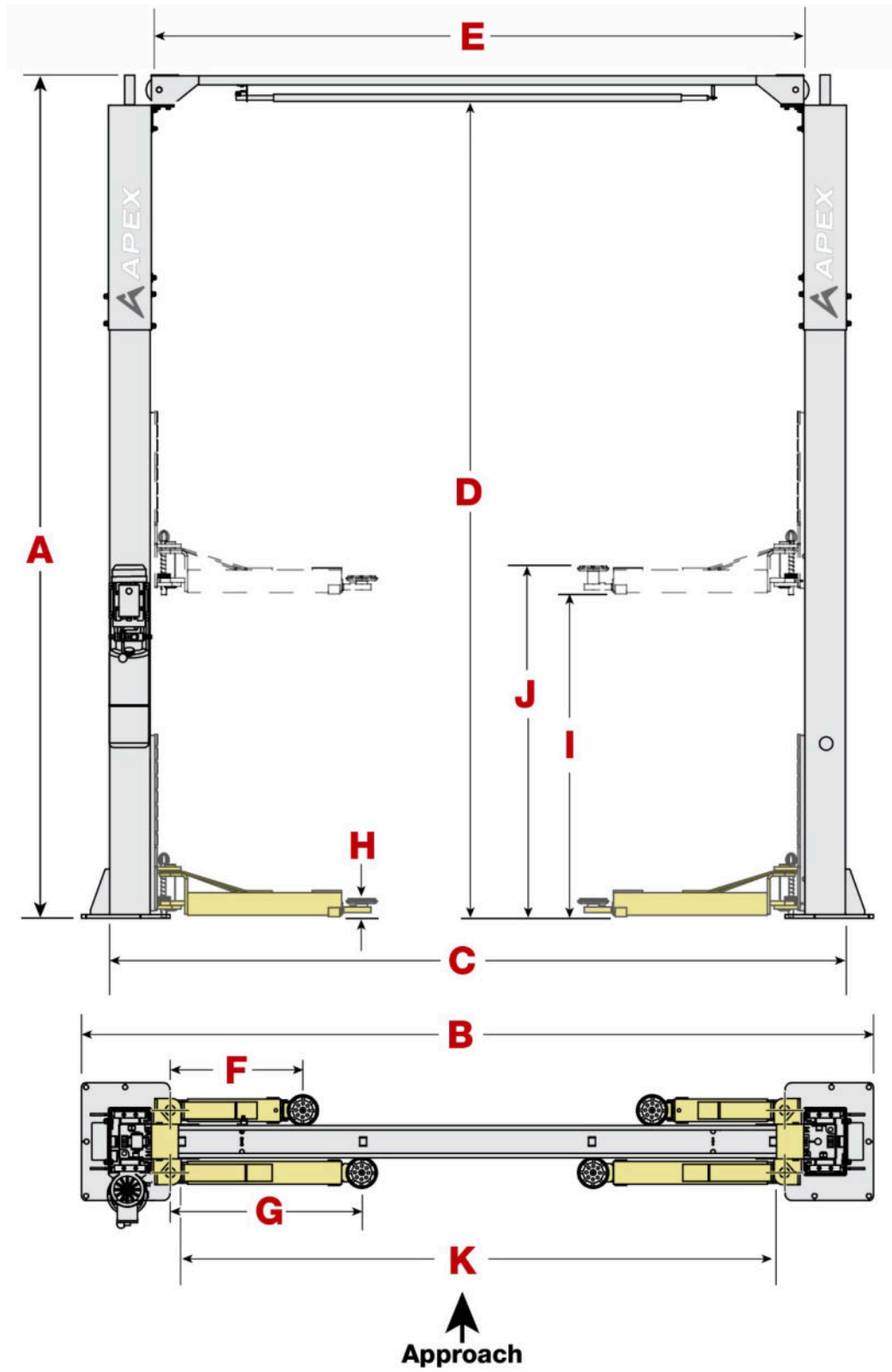

Illustration for reference only. Do not scale.

Specifications

MODEL	AL10C
Lifting Capacity	10,000 lbs. (4,536 kg)
Max Capacity / Front Axle	5,000 lbs. (2,268 kg)
Max Capacity / Rear Axle	5,000 lbs. (2,268 kg)
Max Load Per Arm	2,500 lbs. (1,134 kg)
A - Height Overall: (*)	148 in. (3,759 mm)
B - Width Overall (At Baseplate)	137.5 in. (3,492 mm)
C - Width Outside of Columns	128.5 in. (3,264 mm)
D - Floor to Overhead Switch Bar	142.5 in. (3,619 mm)
E - Width Inside Columns	114.5 in. (2,908 mm)
F – Front Arm Reach (Min.)	22.5 in. (571 mm)
F – Front Arm Reach (Max.)	43.25 in. (1,099 mm)
G – Rear Arm Reach (Min.)	33.25 in. (845 mm)
G – Rear Arm Reach (Max.)	53.25 in. (1,353 mm)
H - Min. Pad Height	3.9 in. (100 mm)
I - Rise	70 in. (1,778 mm)
J - Max Lift Height (Screw Pad w/63mm Adapter)	76.5 in. - 78.5 in. (1,943 – 1,994 mm)
K - Drive-Thru Clearance	103 in. (2,618 mm)
Screw Pad Adjustment	2 in. (51 mm.)
Motor	208-230 VAC / 60 Hz / 1 Ph / 23A
Time to Full Rise	65 seconds
Shipping Weight	1,550 lbs. (703 kg)

* To top of cylinder when lift is raised to maximum height.

Add dimensions rounded to the nearest .25 in. (6.3 mm)

The design, material and specifications are subject to change without notice.

Installation Checklist

The following steps are required to install an AL10C Two-Post Lift. Perform them in this order.

- 1. Review all the safety rules in this manual.
- 2. Make sure all the necessary tools are available.
- 3. Plan for all electrical work using a licensed electrician.
- 4. Review the Installation orientation instructions.
- 5. Review the clearances around the Lift.
- 6. Select the installation location.
- 7. Learn about hydraulic fluid contamination.
- 8. Route the Hydraulic Hoses.
- 9. Create chalk line guides for the Posts.
- 10. Anchor the Posts.
- 11. Prepare and install the Overhead Assembly and Safety Shutoff Bar.
- 12. Connect the Equalizing Cables.
- 13. Mount the Power Unit (*but do not connect it to power yet*).
- 14. Connect the Hydraulic Hoses and ensure that all Hydraulic Connections are secured.
- 15. Install the Lift Arm Assemblies.
- 16. Perform a final leveling.
- 17. Contact the electrician.
- 18. Connect the Limit Switch wiring (***electrician required***).
- 19. Connect the Power Unit (***electrician required***).
- 20. Install the Power Disconnect Switch (***electrician required***).
- 21. Install a Thermal Disconnect Switch, if required by local code (***electrician required***).
- 22. Lubricate the Lift.
- 23. Perform an operational test.
- 24. Review the final checklist.
- 25. Leave the manual at the Lift for the owner/operator.

Installation

The installation process includes multiple steps. Perform them in the order listed in this manual.

 **WARNING** Use only the factory-supplied parts shipped with the AL10C Lift. Using attachments, accessories, or modifying components that are in the path of and/or affect the operation of the equipment, affect the equipment's electrical listing, or affect the intended vehicle accommodation, and are not certified for use with this Lift, void the warranty of the Lift as well as compromise the safety of everyone who sets up or uses the Lift. If parts are missing, visit [BendPak.com/Support](https://www.bendpak.com/Support), email support@bendpak.com or contact BendPak technical support by phone at **(800) 253-2363**. Follow the prompts to reach sales. Online chat is also available at www.bendpak.com. Click the chat icon. 

Reviewing the Safety Rules

When installing a Lift, operator safety depends on proper training and thoughtful operation. BendPak recommends referring to the ANSI/ALI ALIS Standard *Safety Requirements for Installation and Service* for more information about safely installing, using, and servicing the Lift.

 **WARNING** Do not allow the installation of this equipment unless the installer has automotive lift installation training. Always use proper lifting tools, such as a forklift or shop crane, to raise heavy components. Do not install this equipment without first reading and understanding this manual and all of the labels on the Lift.

 **WARNING** Appropriate OSHA approved protective equipment must always be worn during installation, including leather gloves, steel-toed work boots, eye protection, back belts, and hearing protection.

Gathering The Tools and Supplies

The following tools are required:

- Rotary hammer drill (or similar)
- 3/4-in. carbide bit (conforming to ANSI B212.15)
- Hammer and crowbar
- 4 ft. (1.2 m) level
- Open-end wrench set (SAE and metric)
- Socket and ratchet set (SAE and metric)
- Hex-key wrench set
- Crescent and pipe wrenches
- Torque wrench
- Four sawhorses
- Medium-sized flat screwdriver
- Tape measure, 25 ft. (7.3 m) or more
- Needle-nose or circlip pliers
- Forklift or shop crane
- Two 12 ft. (3.7 m) ladders
- Chalk line
- Hydraulic fluid: 3.2 gal. (12.1 liters) for 5585144; 3.6 gal. (13.6 liters) for 5585780
- White lithium spray lubricant
- Red lithium grease
- Wire rope lubricant

Preparing for Electrical Work

A licensed electrician will be required at some point during the installation.

⚠ DANGER All wiring **must** be performed by a licensed electrician in accordance with applicable local, state, and federal electrical codes, rules, and regulations, such as state and federal OSHA regulations and electrical codes. There are numerous variations in electrical wiring, local codes, and dangerous errors are often made that cannot be covered in this manual. Avoiding these problems requires the proper equipment and training that a licensed electrician provides.

NOTICE Notify the electrician in advance, so they arrive prepared with the items required to connect to the facility's power system, or an appropriate power cord with plug to connect to an appropriate VAC power source, a Power Disconnect Switch, and a Thermal Disconnect Switch, if required by the local electrical code. ***These items are not supplied with the Lift.***

The electrician needs to:

- **Connect to the facility's power source.** The Power Unit is delivered with a pigtail for wiring to a power source. Have the electrician connect a power cord with plug to the electrical box on the Lift for connection to a power outlet or have them wire it directly into the electrical system at the Lift location. The Lift's Power Unit must be protected by an appropriate circuit breaker.
- **Connect the Limit Switch wiring to the Power Unit.** The Limit Switch must be wired to the Power Unit. The required wiring is included with the Lift.
- **Install a Power Disconnect Switch.** A Power Disconnect Switch is used to shut down the Lift in the event of an electrical circuit fault, emergency, or when the Lift is being serviced. Refer to **Installing a Power Disconnect Switch** for more information.
- **Install a Thermal Disconnect Switch, if required by local electrical codes.**

Installation Orientation

Keep the following in mind when deciding on how to orient the Lift:

- The first thing to determine is which direction vehicles will be driven in, called **the Approach**.
 - In most cases this is a simple decision. With a driveway on one side of the Lift and a wall on the other side, the driveway is the Approach side. This makes the wall side the front of the Lift and the driveway side the rear of the Lift.
 - If both sides are open, decide which direction vehicles will be driven onto the Lift. This is the approach. The **drive-on** side is the rear of the Lift, and the **drive-off** side is the front.
- While the Power Unit *can only be* installed on the Power Side Post, that Post may be mounted on either side of the Lift. The Power Side Post can be identified by the mounting bracket, which the Power Unit attaches to. Refer to the illustrations below.

Top View: Approach Side

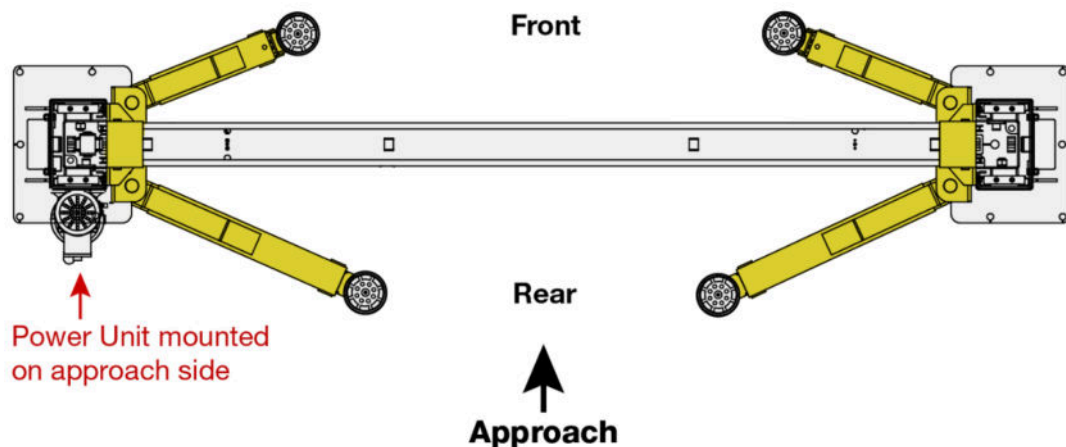

Top View: Opposite Approach

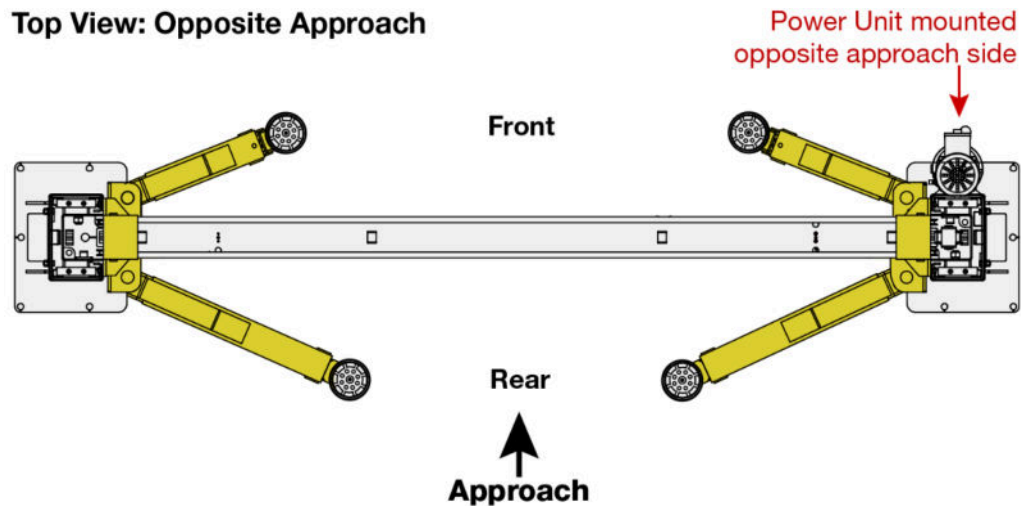

⚠ CAUTION!

Orient the Overhead Assembly so that the Limit Switch is located on the Power Unit side of the Lift.

Clearance around and above the Lift is **required for safety**. Refer to the illustrations below.

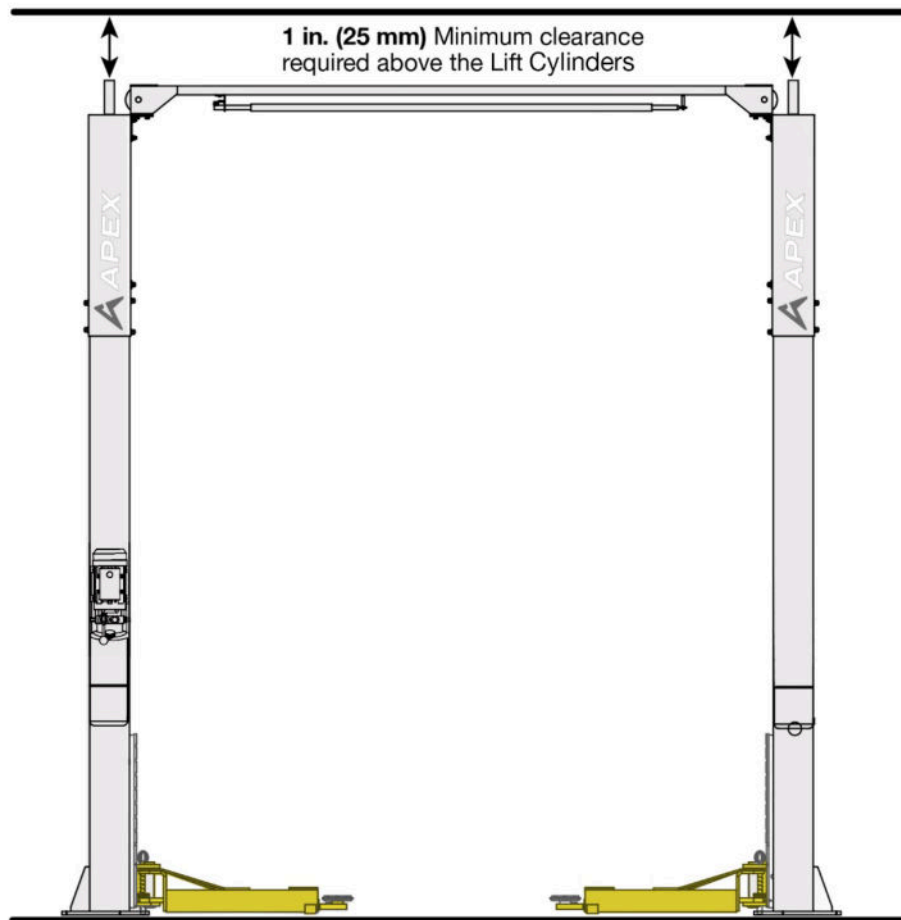
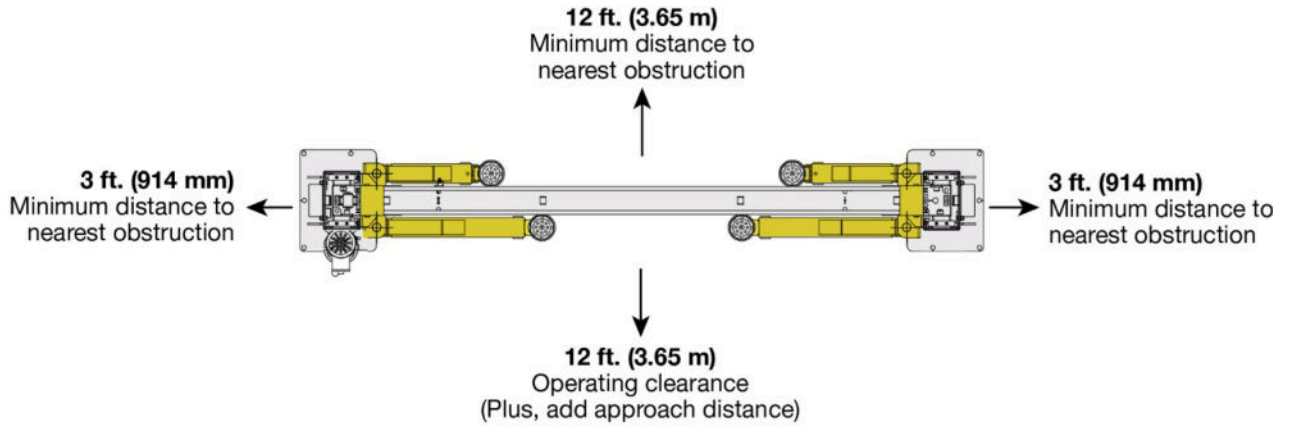

Illustrations not to scale. Additional distance may be required on the front and rear to allow vehicles to be driven in or out from these directions.

Selecting a Location

When selecting the location for the Lift, consider the following:

- **Architectural plans.** Consult the architectural plans for the desired location. Make sure there are no contradictions between the position of the Lift and what the plans will allow.
- **Available space.** Make sure there is enough space for the Lift: front, back, sides, and *above*. Refer to **Specifications** for exact measurements. Check for overhead obstructions such as building supports, heaters, lights, electrical lines, low ceilings, and so on.
- **Power.** An appropriate electrical power source is required for the Lift's Power Unit.
- **Outdoor installations.** The AL10C Two-Post Lift is approved for indoor installation and use only. ***Outdoor installation is prohibited.***
- **Floor.** Only install the Lift on a flat, steel reinforced concrete floor. Do not install on asphalt or any other surface. The surface must be level. ***Do not install the Lift*** if the surface has a slope greater than or equal to 3°.

 **DANGER** Installing the Lift on a surface with more than three degrees of slope could lead to injury or even death. Only install the Lift on a level floor (defined as no more than 3/8 in. (9.5 mm) difference over the installation area). If the floor is not level, consider making the floor level or using a different location.

 **DANGER** **Risk of explosion:** This equipment has internal arcing or parts that may spark and should not be exposed to flammable vapors. The Power Unit's motor should not be located in a recessed area or below floor level.

 **WARNING** Never expose the motor to rain or other damp environments as damage to the motor caused by water is not covered by the warranty.

- **Concrete specifications.** The concrete must be a minimum 4.25 in. (108 mm) thick, 3,000 PSI minimum compressive strength, and cured for a minimum of 28 days. Do not install the Lift on cracked or defective concrete. Anchor Bolts must be more than 6 in. (152 mm) from cracks and expansion joints in the concrete or from a wall.

 **CAUTION** BendPak Lifts are supplied with installation instructions and concrete anchors that meet the criteria set by the latest version of the American National Standard in Automotive Lifts – Safety Requirements for Construction, Testing, and Validation in., ANSI/ALI ALCTV. Consult with an expert for any special regional structural and/or seismic anchoring requirements specified by any other agencies and/or codes such as the Uniform Building Code (UBC) and/or International Building Code (IBC).

Check the floor for the possibility of it being a post-tension slab. In this case, contact the building architect **before** drilling. Ground penetrating radar can be used to help in finding tensioned steel.

 **DANGER** Cutting through a tensioned cable can result in injury or death. Do not drill into a post-tension slab unless the building architect confirms that tensioned steel will not be hit, or tensioned steel has been located using ground penetrating radar. ***If colored sheath comes up while drilling, stop drilling immediately.***

- **Unloading the components.** Unload the Lift components as close to the installation location as possible. The Lift includes several heavy pieces, so the closer they are unloaded to the final installation location, the better.

⚠ WARNING

Some Lift components are very heavy and, if handled incorrectly, can damage materials like tile, sandstone, and brick. Attempt to handle the Lift components only twice: once when delivered and once when moved into final position. A forklift or shop crane is required to move some of the Lift components into position. **Use great care when moving Lift components.**

Creating Chalk Line Guides

Based on the Lift Specifications, create chalk line guides on the ground at the location where the Lift will be positioned.

The following illustration shows the AL10C Lift positioned within the chalk lines.

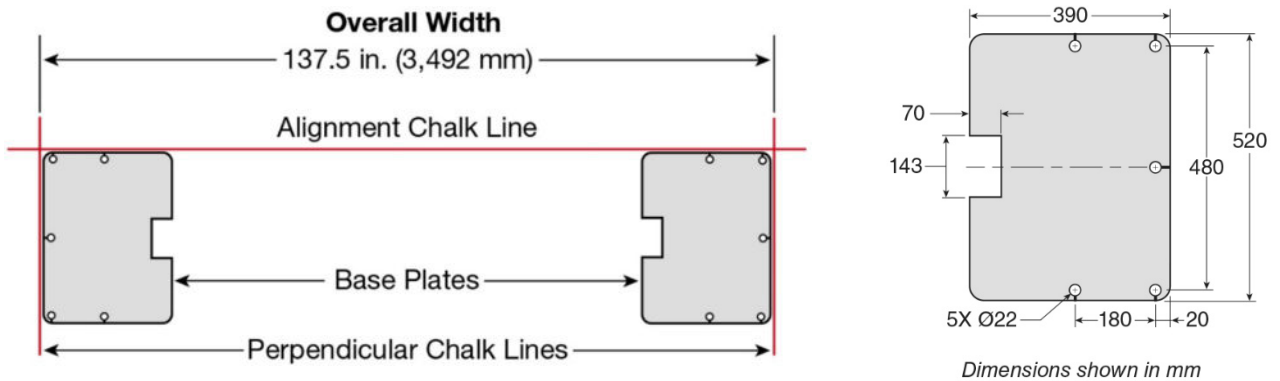

Top View of Base Plates. Not to scale. Not all components are shown.

When moving the Posts into position (later in the installation), put the Base Plates into the corners created by the Chalk Line Guides, as shown in the illustration above.

Adding Chalk Line Guides:

1. Decide where to locate the Lift. Verify the clearances around the Lift area.
2. Create an Alignment Chalk Line at the front of the Lift as shown in the illustration above.
Make the Alignment Chalk Line slightly longer than the **Overall Width** of the Lift.
3. Mark the Alignment Chalk Line at points 137.5 in. (3,492 mm) apart for the **Overall Width**.
4. Create two Perpendicular Chalk Lines at 90° angles to the Alignment Chalk Lines at the **Overall Width** distance, making them at least 24 in. (610 mm) long.
5. Mark the Perpendicular Chalk Lines at 24 in. (610 mm) from the Alignment Chalk Line.
6. Measure diagonally from corner to corner, as shown in the illustration below. If the diagonal measurements are identical, then the Perpendicular Chalk Lines are correct.

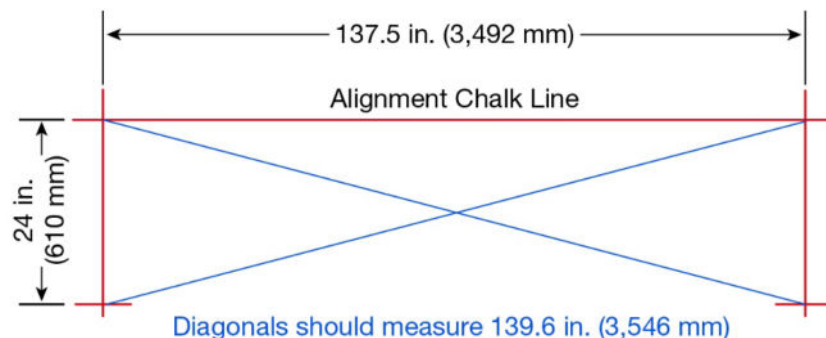

Installing the Post Extensions

- Carefully position each Post and Post Top Extension on the ground as shown. It is recommended to place a material such as cardboard on the ground first to avoid scratching the Posts.

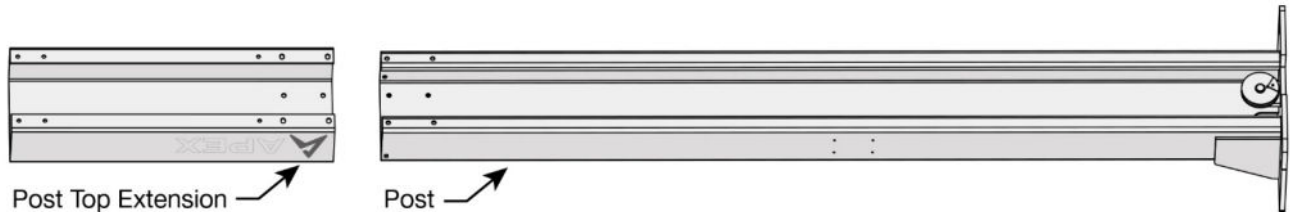

- Slide the Post Top Extension over the Post, aligning the mounting holes.



Illustrations not to scale. Not all components shown.

- Securely bolt the Post Top Extensions to each post following the steps below.
 - As shown in **illustration A** below, insert four bolts through the holes on the open side of the Post, facing outward. Secure each bolt with a locking washer and nut. **Torque bolts to 60 ft.-lbs.**
 - To insert the next four bolts, through the back of the Posts, the Posts will need to be turned onto their sides.

As shown in **illustration B** below, insert four bolts through the back holes in each Post, from the inside facing outward. On the opposite side of the Post, secure each bolt with a locking washer and nut. **Torque bolts to 60 ft.-lbs.**

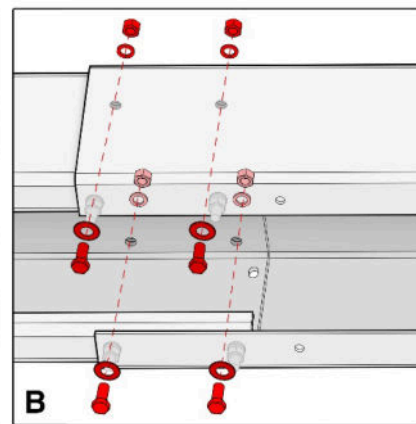
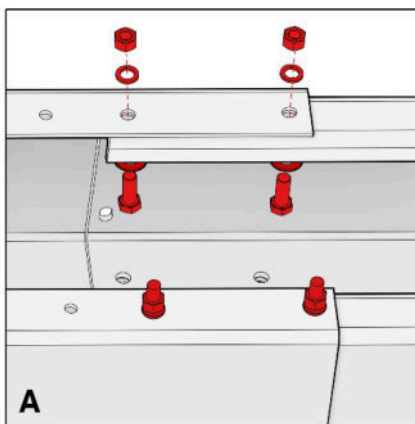

- M12 x 1.75 Bolts (8 ea. Post)
- M12 Flat Washers (8 ea. Post)
- M12 Lock Washers (8 ea. Post)
- M12 Hex Nuts (8 ea. Post)

- Install the Securing Bracket on each Post using two M10 x 15 mm Bolts, Flat Washers and Hex Nuts.

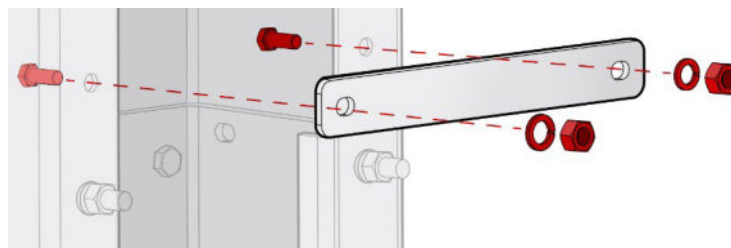

- Unwrap the Hydraulic Hose from within one Post and pull it out through the top end of the Post.

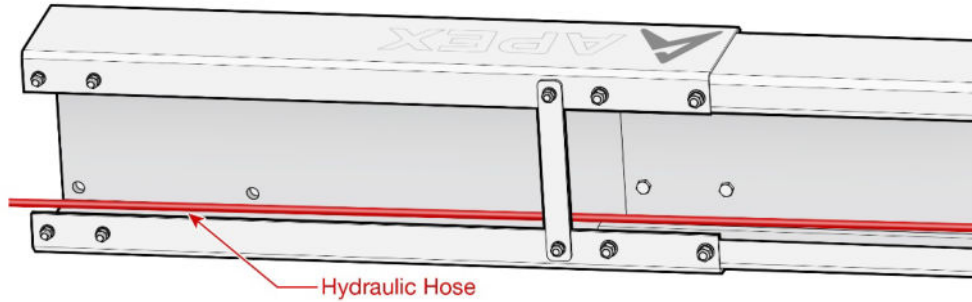

- Insert two Hydraulic Hose Retainers over the Hydraulic Hose and position them by the retaining holes near the top of the Post, as shown in the illustrations above and below.
- Gently pull the Hydraulic Hose from the top of the Post, to ensure that it is not loose within the Post, then secure the two Hydraulic Hose Retainers with the provided bolts, washers and nuts.

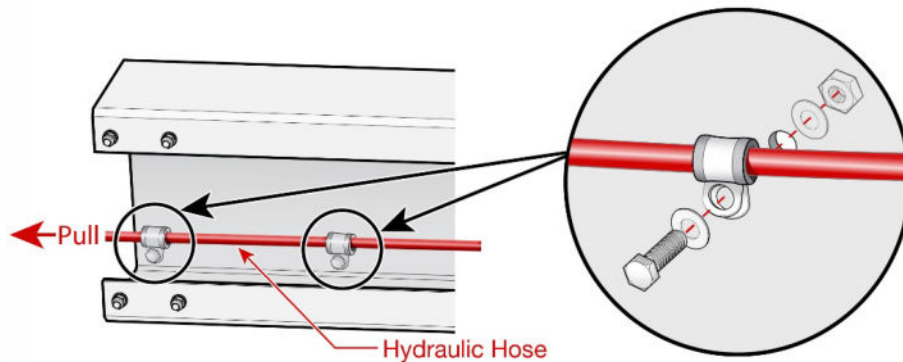

- Wrap the excess Hydraulic Hose and secure it inside the top of the Post, for final connection later, after the Posts have been raised and the Overhead Assembly has been installed.
- Complete steps 5 through 8 on the other Post.
- Turn the Posts onto their back sides.
- Assemble the Overhead Assembly Mounting Brackets on the top end of each Post.

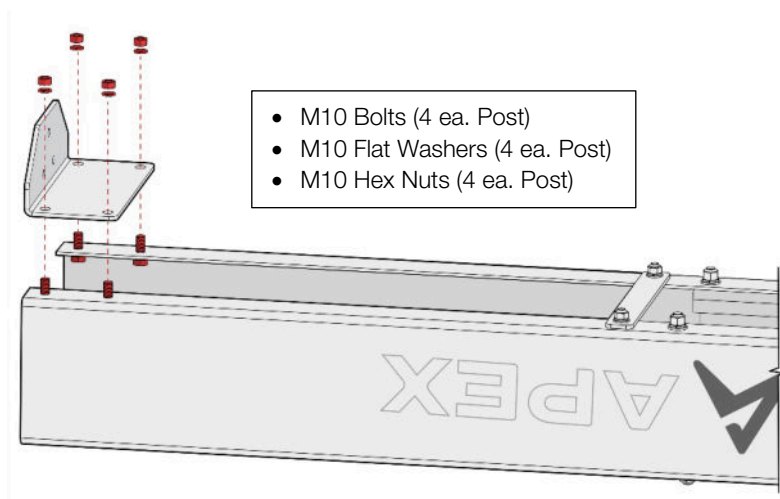

Illustrations not to scale. Some components may vary in appearance.

Raising and Anchoring the Posts

⚠ DANGER Pay special attention when installing the Posts. If done incorrectly, the Lift could fall over, potentially causing damage to a vehicle, the Lift, and injuring bystanders. BendPak strongly recommends consulting a Concrete Specialist early in the planning process for Lift installations. A Concrete Specialist will make necessary adjustments to account for national, state, and local building codes as well as local weather conditions, soil composition, base preparation, load bearing, seismic requirements and any other structural concerns that may arise.

Concrete specifications are:

- **Depth:** 4.25 in. (108 mm) thick (minimum), steel reinforced.
- **PSI:** 3,000 PSI, minimum
- **Cured:** 28 days, minimum

Anchor Bolt specifications are:

- **Length:** 6.3 in. (160 mm)
- **Diameter:** .75 in. (19 mm)
- **Anchor torque:** 85 – 95 ft. lb.
- **Effective embedment:** 3.25 in. (82.5 mm) or more

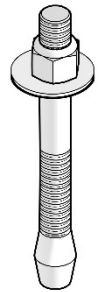

The Concrete floor where the Lift is to be installed **must** meet the following requirements:

- The floor must be a flat, level, concrete floor. **Do not install the Lift on a surface with more than three degrees of slope.**
- Do not install the Lift on cracked or defective concrete.
- Check the floor for the possibility of it being a post-tension slab. In this case, contact the building architect before drilling. Contact a qualified professional to locate the tensioned cables before drilling.

⚠ DANGER Cutting through a tensioned cable can result in injury or death. Do not drill into a post-tension slab unless the building architect confirms that a tensioned cable will not be hit, or any tensioned cables have been located first using ground penetrating radar. **If colored sheath comes up during drilling, stop drilling immediately!**

⚠ WARNING All concrete and Anchor Bolts **must** meet the specifications identified in this manual. Only install the Lift on a concrete surface. If installed on asphalt or any other surface, or the concrete or Anchor Bolts do not meet these specifications, it could lead to product damage, vehicle damage, personal injury, or even loss of life.

BendPak Lifts are supplied with installation instructions and concrete fasteners meeting the criteria as prescribed by the latest version of the American National Standard “Automotive Lifts – Safety Requirements for Construction, Testing, and Validation.”

⚠ WARNING Use **only** the ALI-certified Anchor Bolts that came with the AL10C Two-Post Lift. If components from a different source are used, the warranty will be void and the safety of everyone who installs or uses the Lift will be compromised.

Lift owners are responsible for conforming to all regional, structural, and seismic anchoring requirements specified by any other agencies and/or codes, such as the Uniform Building Code and/or International Building Code.

NOTICE Do *not* torque the Anchor Bolts into position yet. Installing the Overhead Assembly and doing the final leveling will be easier if there is some play in the Posts.

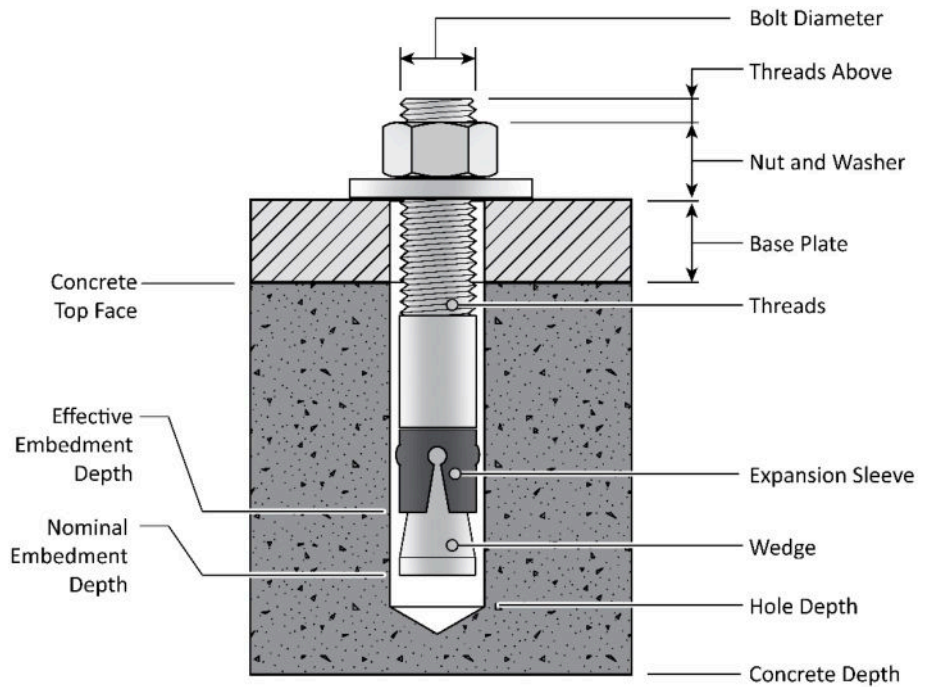

Effective Embedment is the location in the Hole where the Expansion Sleeve presses into the concrete. This is where the Anchor Bolts get their holding strength, the further down into the hole, the greater the holding strength.

Nominal Embedment is how far down into the hole the bottom of the Anchor Bolt is, which does not indicate the holding strength.

Installing the Posts:

1. Using a forklift or shop crane, move the Posts to the Chalk Line Guides created earlier.
2. Carefully stand up each Post, *one at a time*, and move them to the appropriate location.
3. Double check all measurements against the **Specifications** for the Lift.

WARNING Appropriate safety gear, including safety glasses, dust masks, gloves, steel-toed work boots, and heavy work clothes **must be used** when anchoring the Posts.

4. Using the Base Plates as guides, drill each hole **4 in. (102 mm)** deep using a carbide bit.

Drill straight. Do not let the drill wobble.

The diameter of the drill bit must be the same as the diameter of the Anchor Bolt. If using a 3/4 in. diameter Anchor Bolt, for example, use a 3/4 in. diameter drill bit.

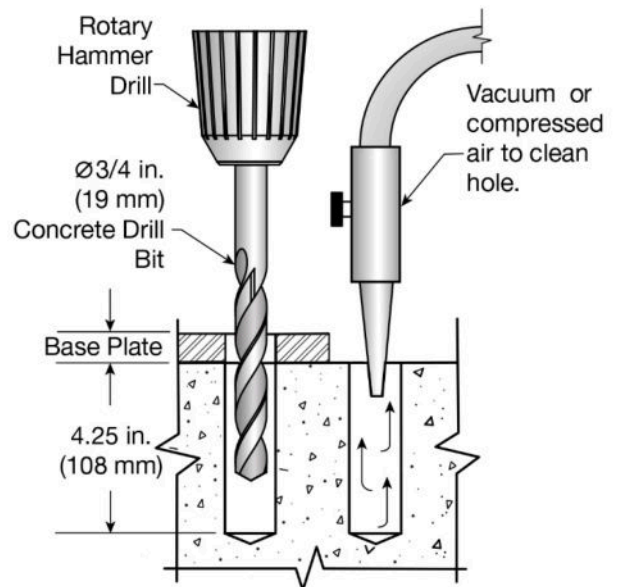

Do not drill all the way through the concrete as this could compromise the holding strength of the Anchor Bolts.

5. Thoroughly vacuum each hole clean to remove all debris.

A wire brush, hand pump, or compressed air may also be used. **Make sure to thoroughly clean each hole.**

Do **not** ream the hole. Do **not** make the hole any wider than the drill bit made it.

NOTICE The holding strength of an Anchor Bolt is partially based on the how cleanly the Expansion Sleeve presses against the concrete. If the hole is dirty or too wide, the result is less holding strength.

6. Make sure the Washer and Nut are in place, then insert the Anchor Bolt into the hole.

The Expansion Sleeve of the Anchor Bolt may prevent the Anchor Bolt from passing through the hole in the Base Plate. This is normal. Use a hammer or mallet to get the Expansion Sleeve through the Base Plate and into the hole.

Even using a hammer or mallet, the Anchor Bolt should only go into the hole part of the way. This is normal. If the Anchor Bolt goes in all the way with little or no resistance, the hole is too wide.

Once past the hole in the Base Plate, the Anchor Bolt eventually stops going down into the hole as the Expansion Sleeve contacts the sides of the hole. This is normal.

7. Hammer or mallet the Anchor Bolt the rest of the way down into the hole and then stop when the Washer is snug against the Base Plate.
8. Plumb each Post using a plumb bob.
9. Install Shims as required, but do not shim more than .5 in. (13 mm).

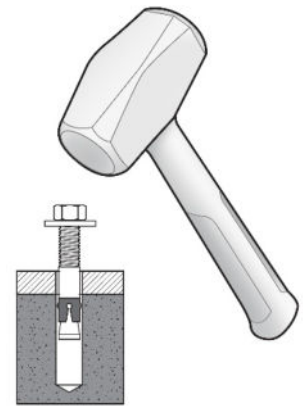

WARNING Avoid excessive Shim heights! A new concrete cutout and steel reinforced pour are recommended to correct out of level conditions in excess of 3°.

Tip If torquing the Anchor Bolts later, so that installing the Height Adapter Holders and the Overhead Assembly, and final leveling, is easier, skip the next step. However, make sure the Anchor Bolts are securely in position as this will ensure that the Posts remain stable and aligned during the rest of the installation.

10. Tighten each nut to the recommended installation torque of 85 – 95 lb.-ft., using a Torque Wrench.

CAUTION Do **not** use an impact wrench to torque the Anchor Bolts.

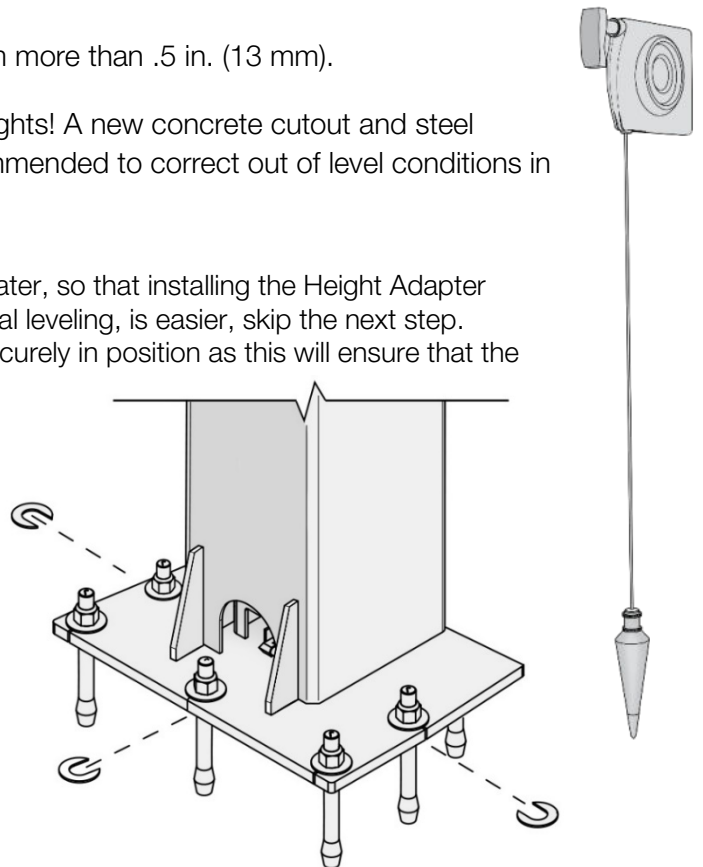

Assembling the Overhead Assembly and Safety Shutoff Bar

The Overhead Assembly is installed above and between the Power Side and Off-side Posts. It holds the Equalizing Cables, Hydraulic Hoses, the Limit Switch and its wiring.

The Overhead Assembly is made up of three pieces, two halves and a bracket in the center that is used to connect them.

NOTICE BendPak recommends placing the Overhead Assembly components on four sawhorses to prepare them for assembly.

CAUTION Be careful when positioning the Overhead Assembly components on the sawhorses to avoid damage to the pre-installed Limit Switch on the underside.



Prepare and install the Overhead Assembly:

1. Locate the two Overhead Assembly pieces, the Center Bracket, and 10 sets of Hex Head Bolts, Washers, and Hex Nuts.
2. Slide the two Overhead Assembly pieces together, into the Center Bracket.

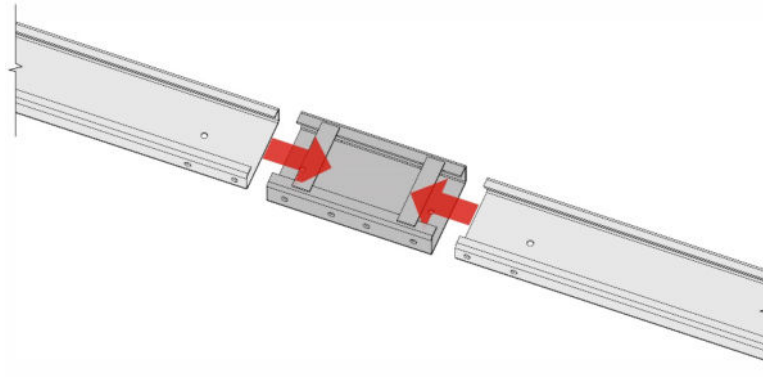

3. Secure both halves of the Overhead Assembly to the Center Bracket using the 10 sets of Hex Head Bolts, Washers, and Hex Nuts, as shown to the right.

- M10 x 30 mm Bolts (10 pcs.)
- M10 Flat Washers (10 pcs.)
- M10 Hex Nuts (10 pcs.)

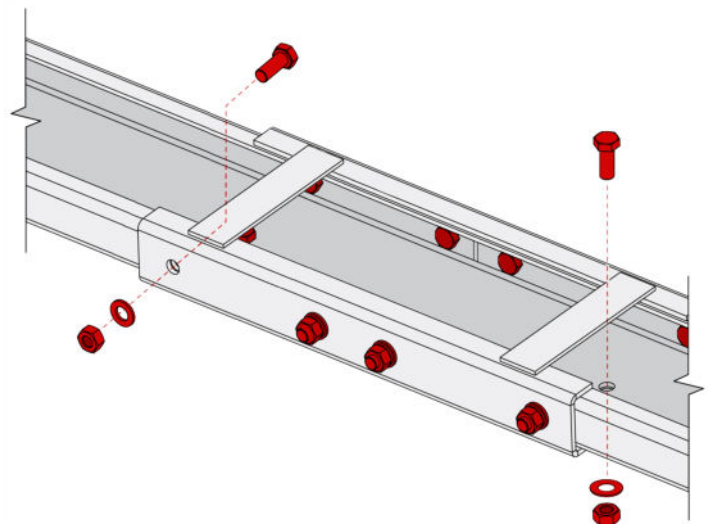

- Turn the Overhead Assembly over and install the Safety Shutoff Bar Assembly Mounting Bracket.

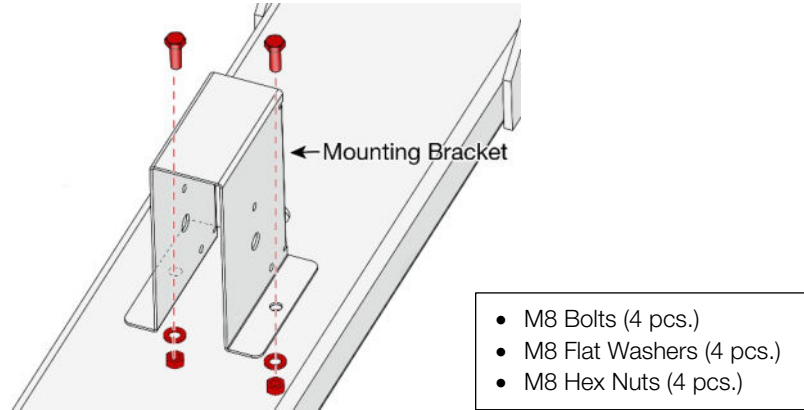

- Install the Limit Switch Assembly to the opposite end of the Overhead Assembly.

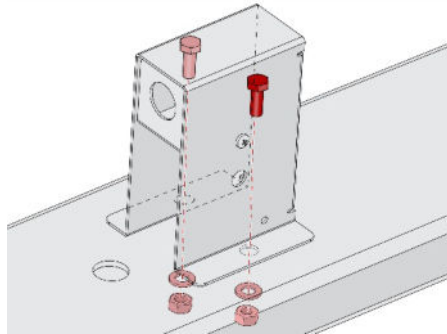

- Insert the rod end of the Safety Shutoff Bar Assembly into the opening in the Limit Switch, by first depressing the Limit Switch Activator, as shown in **Illustration A** below.
- Connect the other end of the Safety Shutoff Bar Assembly to the Retainer Pin using the provided Cotter Pin, as shown in **Illustration B** below.

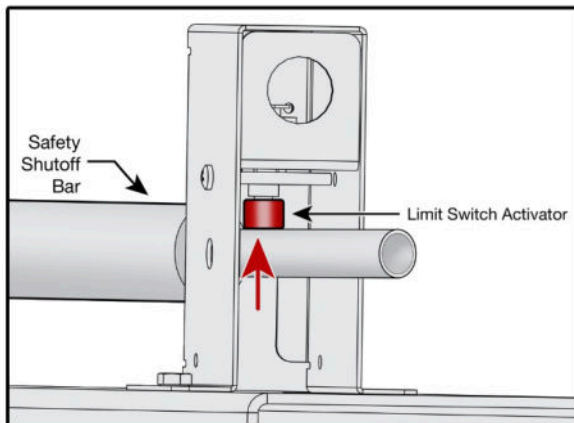
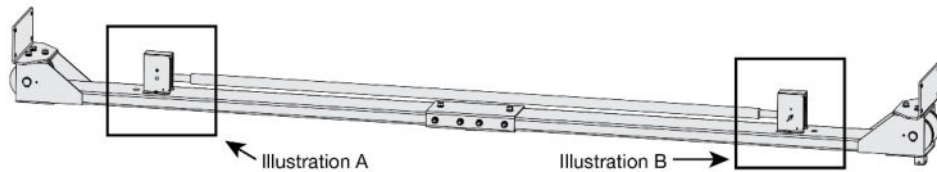

Illustration A

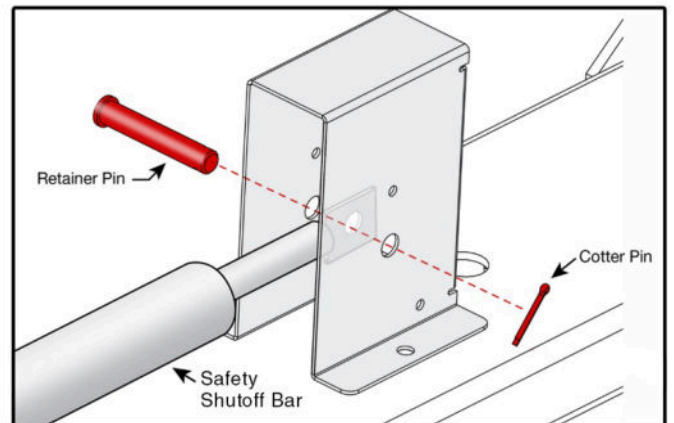
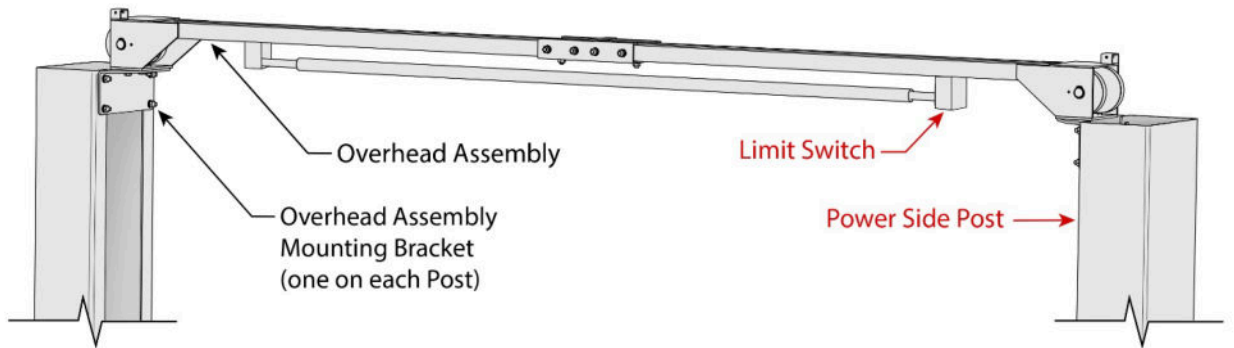

Illustration B

- Using a shop crane or forklift, raise the Overhead Assembly into position between each Post, resting it on the Overhead Assembly Mounting Brackets.

Do **not** remove the crane or forklift until the Overhead Assembly has been securely attached to both Posts.

IMPORTANT The Limit Switch side of the Overhead Assembly **must** be positioned on the Power Post side of the Lift.



- Secure each end of the Overhead Assembly to the Mounting Brackets on each Post.

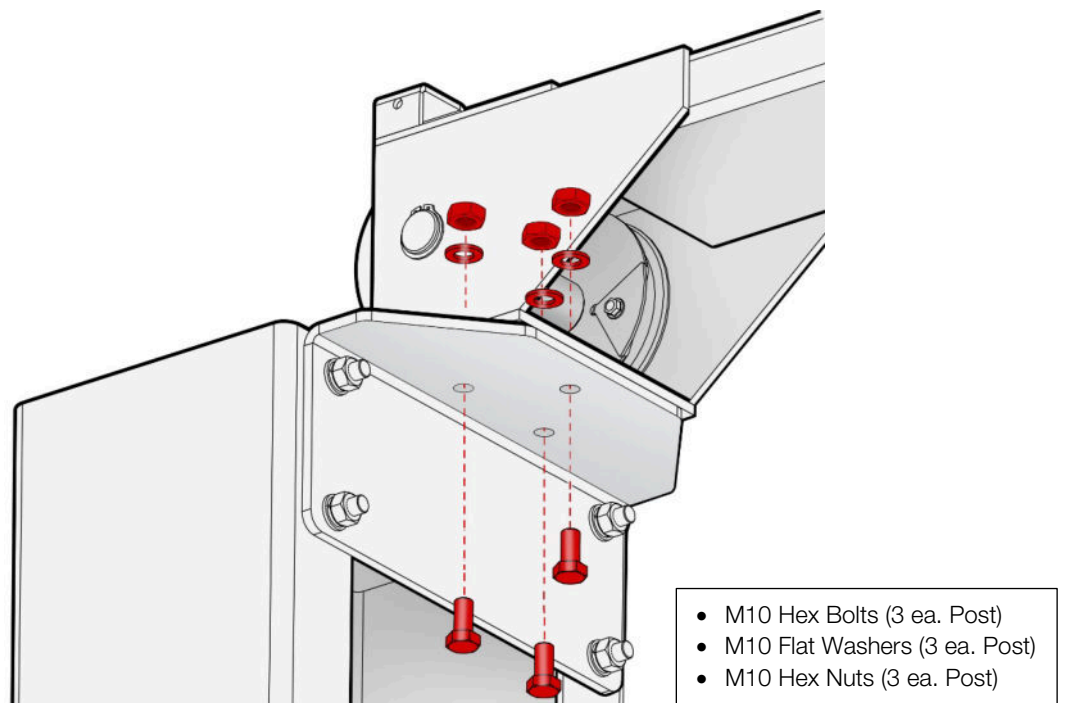

Illustrations not to scale. Some components may vary in appearance.

Installing the Equalizing Cables

When the Equalizing Cables are correctly routed, they are mirror images of each other. Both Equalizing Cables come pre-installed within each Post, connected to the upper Lift Heads. Each one will need to be routed up and over the Overhead Assembly, down the opposite Post, around the lower Cable Sheaves, then up to the Lift Heads, where they will be secured. Refer to the illustration below.

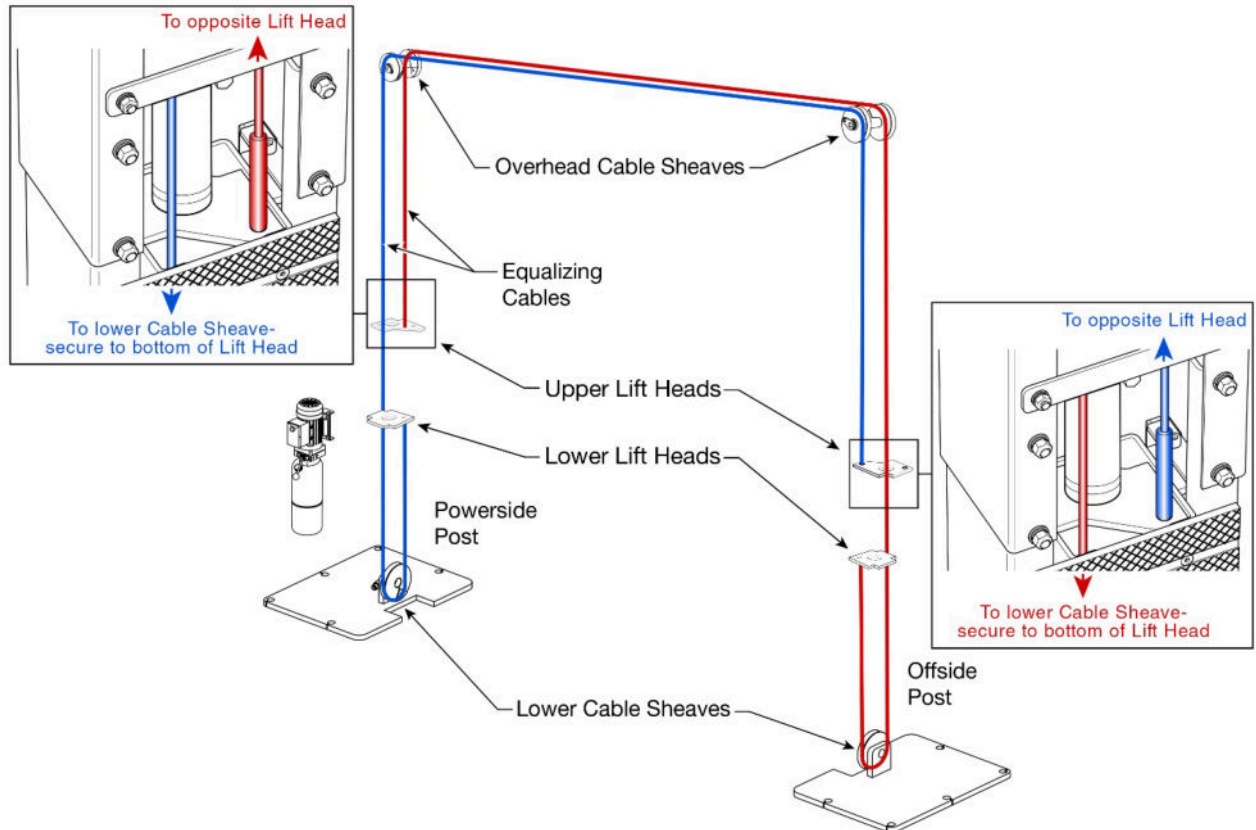

When the Equalizing Cables are correctly routed, they are mirror images of each other. Refer to the illustrations below

Illustrations not to scale. Posts and other components removed for clarity

Routing the Equalizing Cables:

⚠ WARNING A proper lifting device such as a forklift or shop crane must be used to raise and position the Lift components.

1. Using a forklift or shop crane, manually raise both Lift Heads, one at a time, about 28 in. (711 mm) off the ground and then engage each one on the closest Safety Lock.

Measure to verify that both Lift Heads are the same distance off the ground.

2. Choose which of the two Equalizing Cables to be placed into position first, then remove the nuts and washer from the threaded end of that cable.
3. Route the first Equalizing Cable through the Lower Cable Sheave by following these steps:
 - a) Remove the Cable Retainer.
 - b) Position the flat end of the Cable Sheave at the bottom (six o'clock) position.

- c) Once the Equalizing Cable is positioned within the Sheave, re-install the Retainer.

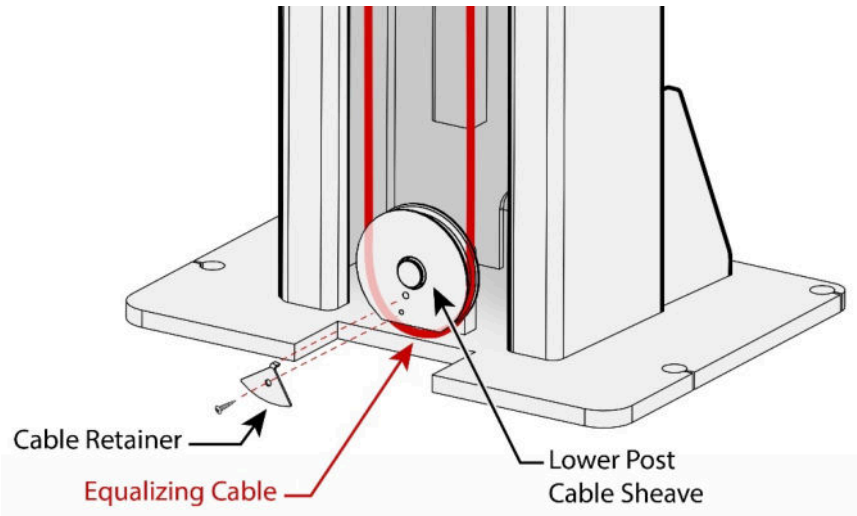

4. Route the open end of the Equalizing Cable up through the Post, out the top, over the Overhead Cable Sheave, and then across the top of the Overhead Assembly.

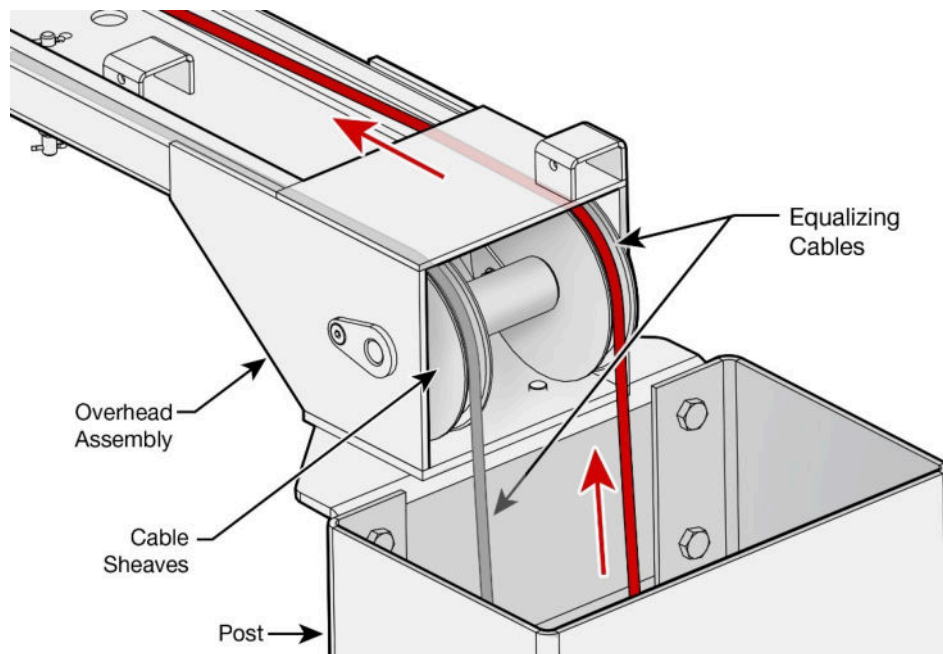

Illustrations not to scale. Not all components shown.

5. Route the Equalizing Cable through the Cable Sheave at the opposite end of the Overhead Assembly, and then down into the Post.

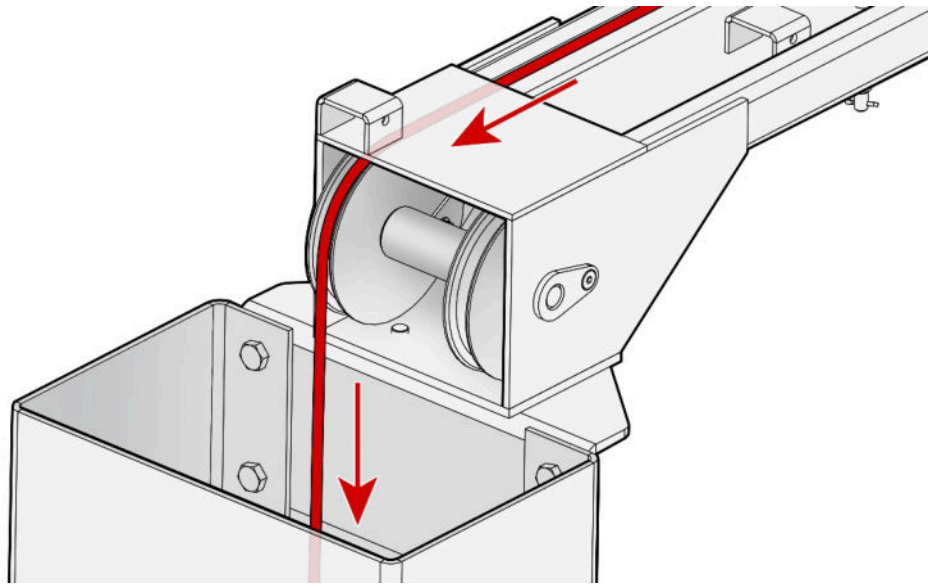

6. Remove the Lift Head Cover to access the upper Lift Head. Put the Lift Head and hardware in a safe place where it can be retrieved (and re-installed) later.

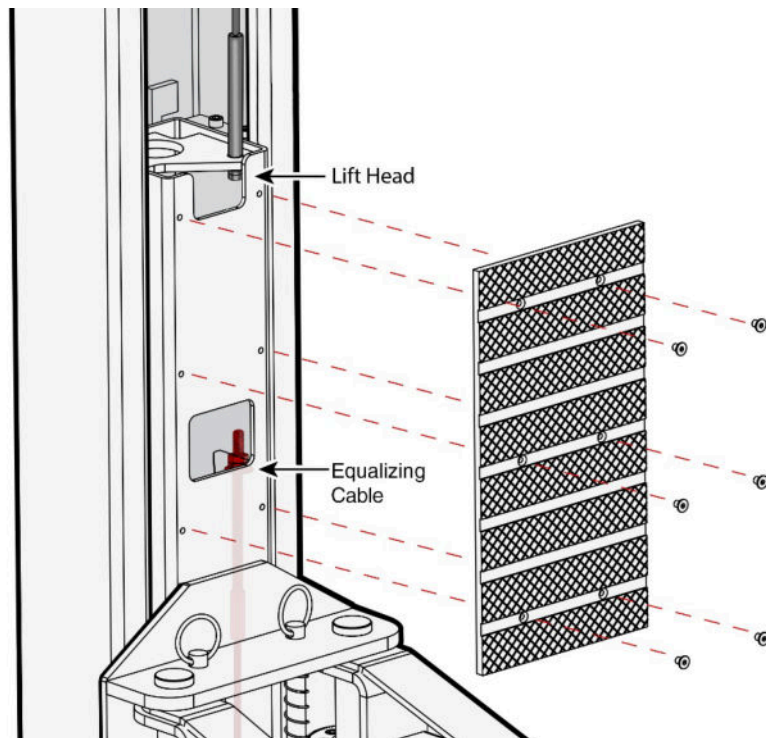

Illustrations not to scale. Not all components shown.

7. Route the open end of the Equalizing Cable up the Post, through the lower opening in the Lift Head Assembly and up to the Cable Weldment, as shown in the illustration below.
8. Complete the connection to the Lift Head using the two hex head nuts and washer removed earlier. Do not fully tighten the cable yet. It will be adjusted and tightened during the leveling process.

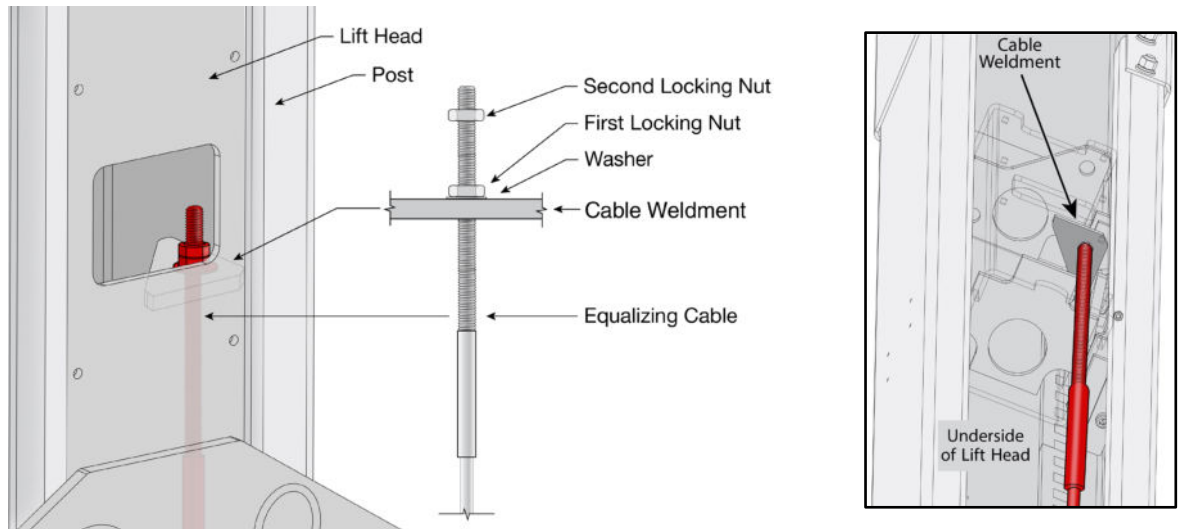

9. Perform Steps 1 through 8 for the other Equalizing Cable.
10. Lubricate all Cable Sheave Pins and Bearings with red lithium grease.

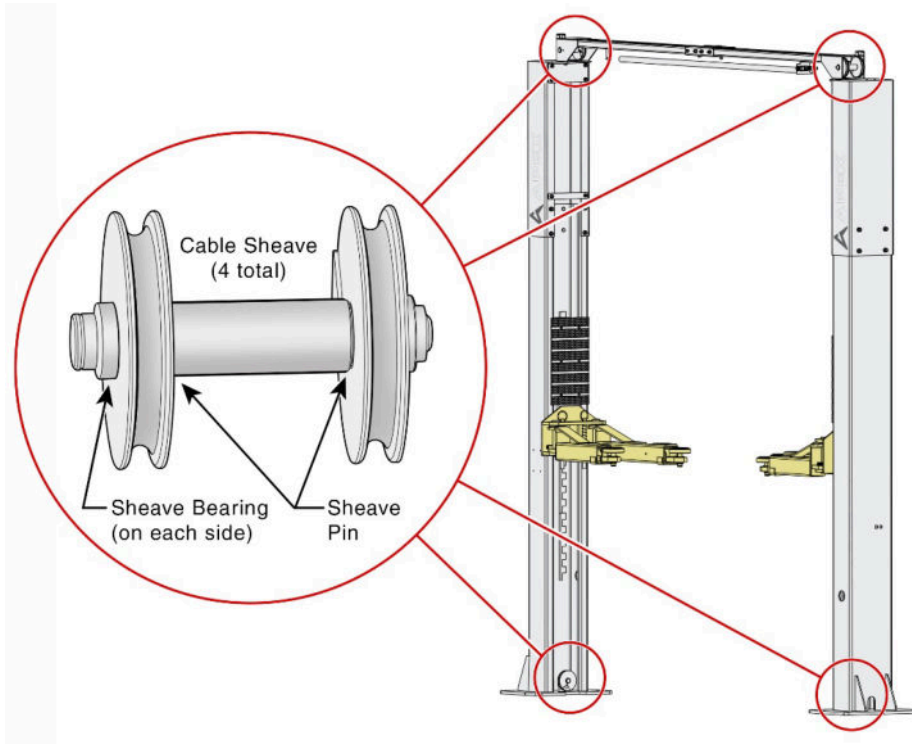

Illustrations not to scale. Not all components shown.

Mounting the Power Unit

This section describes how to mount the Power Unit to the Power Side Post. An electrician is not required to **mount** the Power Unit but will be required to **connect** it to the facilities power source. Refer to **Connecting the Power Unit** for specific information about connecting the Power Unit.

NOTICE Do not connect the Power Unit to the Hydraulic System or to the power source at this point in the installation. These connections will be made later.

CAUTION The Power Unit is heavy. BendPak recommends having one person hold the Power Unit while a second person bolts it into place.

To mount the Power Unit:

1. Retrieve the supplied four M10 x 15 Hex Head Bolts, Self-locking Washers and Nuts.
2. Remove the Power Unit from the packaging material.
3. Secure the Power Unit using the hardware illustrated below, using all four holes on the Power Unit to secure it to the Power Unit Mounting Bracket on the Power Side Post.

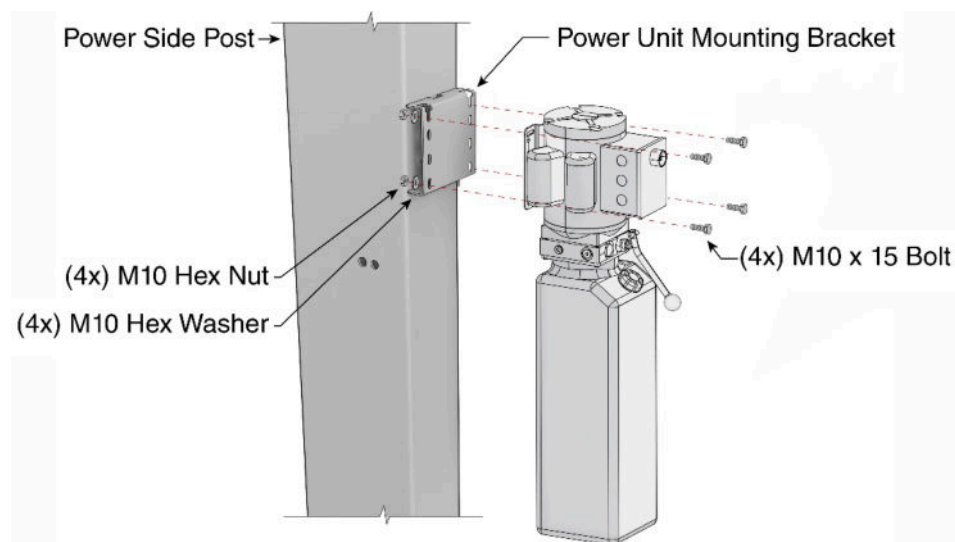

Illustration not to scale. Power Units may vary in appearance.

Mounting the Auxiliary Adapter Holders

The Auxiliary Adapter Holders mount to the bottom of each Post and are used to hold the Auxiliary Adapters.

1. Remove the Nut and Washer from the center Anchor Bolt as shown.
2. Place the Auxiliary Adapter Holder over the Anchor Bolt.
3. Re-install the Nut and Washer and tighten.
4. Repeat steps 1-3 on the opposite Post.

Note: If the Anchor Bolts have previously been torqued, then the removed Nuts can be torqued again to 85–95 lb. ft., using a Torque Wrench. If the Anchor Bolts are to be torqued after final leveling is complete, proceed to the next section without torquing them.

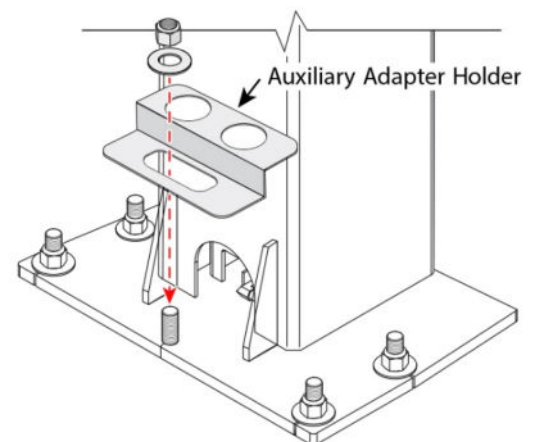



IMPORTANT! PLEASE READ NOW



Hydraulic Fluid Contamination poses a serious issue for any Lift. Contaminants such as water, dirt, or other debris can get into the hydraulic hoses and fittings, making the Lift inoperable.

The AL10C Lift is shipped with clean components, however, BendPak strongly recommends taking secondary precautions and clean all hydraulic hoses and fittings prior to making any connections. It is better, and less costly, to take these extra steps now so that the Lift does not need to be taken out of service later to fix issues that could have been prevented at the time of installation.

There are several ways to clean hydraulic hoses and fittings:

- **Compressed Air.** Use an air compressor to blow out contaminants from each hydraulic hose and hose fitting prior to installation. Clean, dry air is preferred. Wear ANSI-approved eye protection (safety glasses, goggles, or face shield) when using compressed air for cleaning. Never aim an air hose nozzle at any part of the body or at any other person.
- **Fluid Flushing.** If the hydraulic fluid is clean and compatible with the system fluid, hoses and fittings can be flushed to create a turbulent flow that will remove particulates. Always ensure that the fluid used for flushing is contaminant-free.

Some additional steps that will help keep the hydraulic fluid clean:

- **Always use clean equipment.** Using a dirty bucket or funnel to transfer hydraulic fluid into the Hydraulic Fluid Reservoir can introduce contaminants into the system. When using shop towels for cleaning, use only lint-free rags.
- **Proper storage.** Keep the hydraulic fluid sealed in its container until ready for use. Store the fluid in a clean, dry, and cool area.
- **Cover the Hoses and Fittings.** Never leave the ends of any fittings exposed. As a rule, keep the hydraulic hoses and fittings capped and in a clean area until ready for use.
- **Filter the new Hydraulic Fluid.** Just because hydraulic fluid is new does not necessarily mean it is *clean*. Use an offline filtration cart or kidney loop system to make sure the hydraulic fluid is clean before transferring it into the Hydraulic Fluid Reservoir. Even a heavy-duty nylon mesh screen is better than not filtering at all.
- **Avoid mixing different types of Hydraulic Fluids.** If the hydraulic fluid needs to be replaced, make sure to flush the hydraulic system of the old fluid first. Do not mix the old and new together.

Connecting the Hydraulic Hoses

Three of the four Hydraulic Hoses (**B**, **C** and **D**) come pre-packaged within each Post. Hoses **B** and **D** both come pre-assembled at the bottom of each Cylinder. Ensure that Hoses **C** and **D** route through the Hose/Cable Retainers within the Posts before being routed over the Top Assembly and connected.

NOTICE: Before completing this section, ensure that **all** Hydraulic Hose Connections have been securely tightened, including factory-made connections.

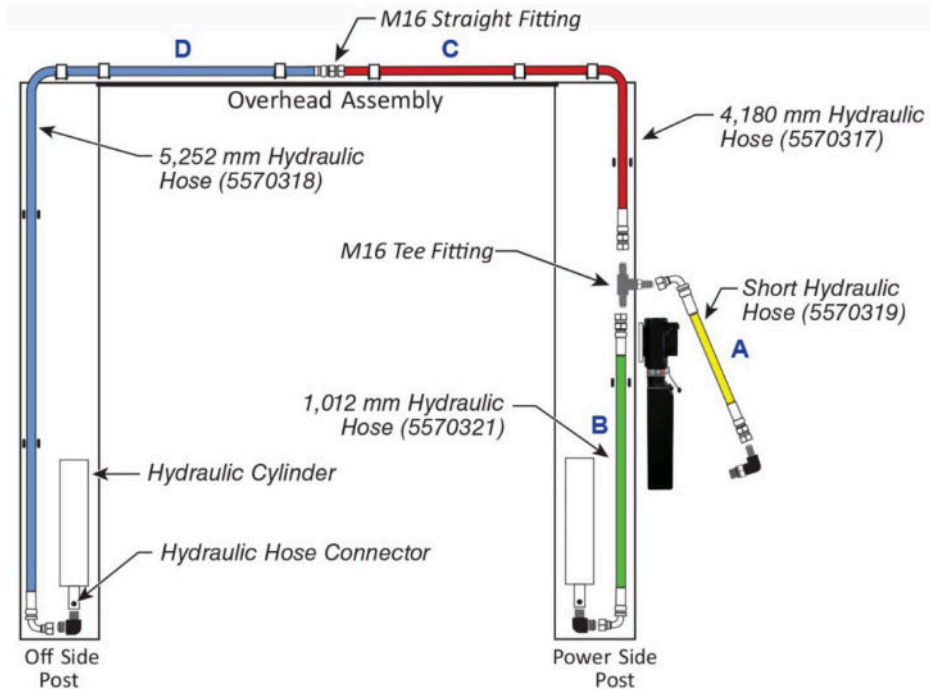

1. Un-coil each Hydraulic Hose at the top of each Post.
2. Route each Hydraulic Hose through the Hose/Cable Retainers and across the Overhead Assembly.

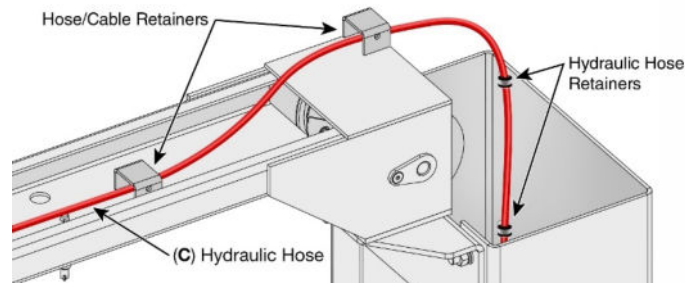

3. Remove the dust caps and connect the Hydraulic Hoses at the middle of the Overhead Assembly using the M16 Straight Fitting. Tighten securely.

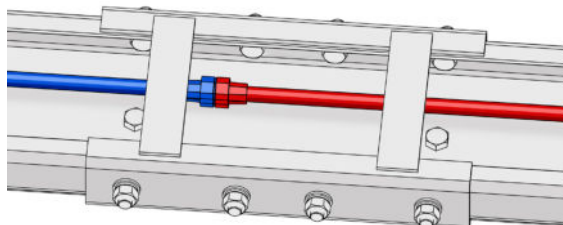

Illustrations not to scale. Some components removed for clarity.

Securing the Hydraulic Port to the Power Side Post:

1. Remove the dust cap and then the Nut from the M16 Tee Fitting on the inside of the Power Side Post.
2. Ensure that Hose **C** and Hose **B** are securely tightened to the M16 Tee Fitting.
3. From the inside of the Power Side Post, press the open male end of the M16 Tee Fitting out through the opening in the Post. The fitting (Hydraulic Port) should be visible from the outside of the Post.
4. From the outside of the Post, tighten the Nut to the M16 Tee Fitting, securing the fitting (Hydraulic Port) to the Post, as shown in the illustrations to the right and below.

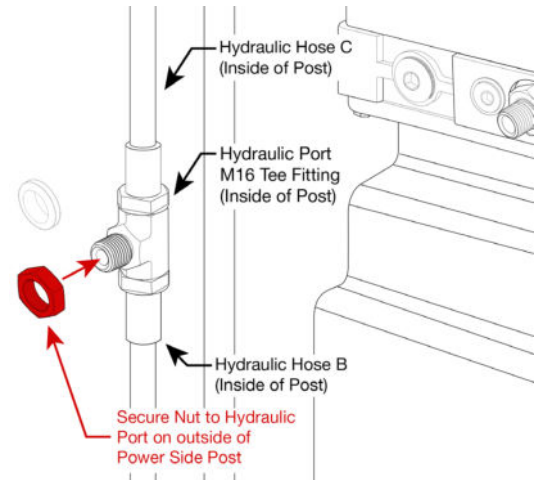

Connecting the Short Hydraulic Hose:

1. Locate the Short Hydraulic Hose. See illustration below for reference.
2. **On the Power Unit**, locate a Hydraulic Pressure Port (labeled P, P1, or P2).
3. Remove the shipping plug and place a few drops of hydraulic fluid on the fitting's O-rings before making the final connections.
4. Align the Short Hydraulic Hose with the Power Unit and the Power Side Post connection to ensure the proper orientation.
5. Connect the Short Hydraulic Hose to the Power Unit and finger tighten.

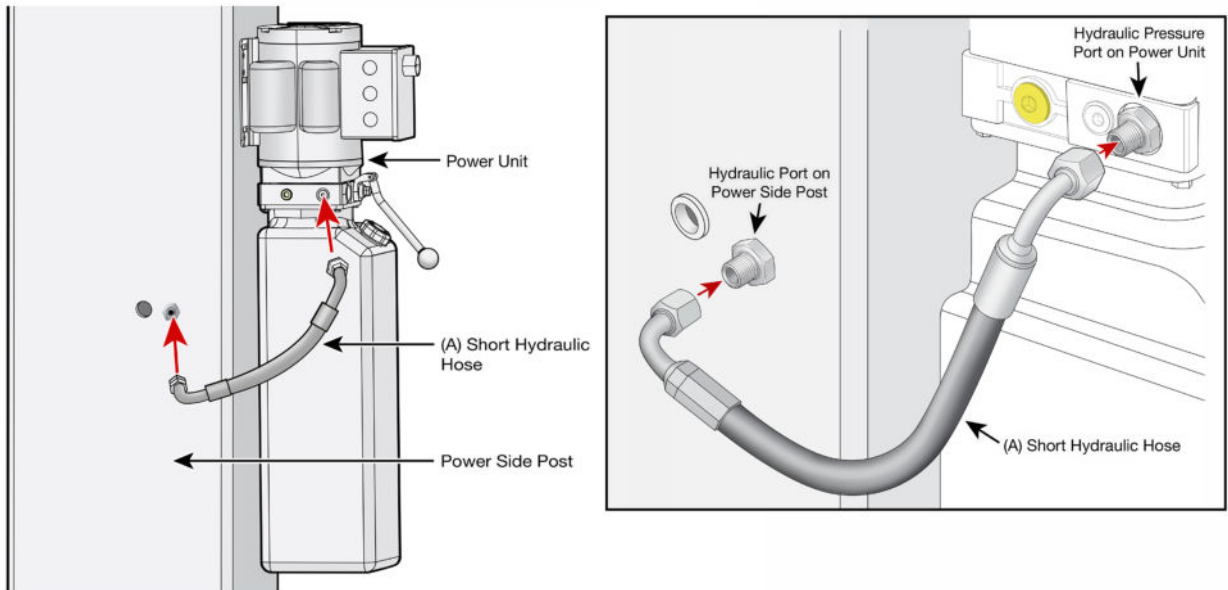

Power Units may vary in appearance. Not all components shown

6. Connect the other end of the Short Hydraulic Hose to the fitting on the Power Post and finger tighten.
7. Once the Short Hydraulic Hose is properly attached, securely tighten both connections.

Installing the Lift Arms

The AL10C Lift comes with four Lift Arms.

There are several rules that govern which Lift Arms go where on a particular Lift.

To determine the Front and Rear of the Lift:

- **If a vehicle can only be driven in one way.** The approach side is the Rear of the Lift and the other side is the Front of the Lift. See illustration below.
- **If a vehicle can be driven in either way.** Choose one side as the Front and the other side as the Rear. The best way to make this decision is to pick one approach direction for the Vehicles being lifted, even though they can be driven in either way. Once the decision is made, the Approach is at the rear of the Lift, and the other side is the Front. See illustration below.

Determine whether the Lift Arm is a 'right' or a 'left.' This is determined separately per Post.

To determine right and left, stand between the two Posts, then turn to face one of them straight on. From this viewpoint, the right side of the Post is the 'right' and the left side of the Post is the 'left.'

After finishing the first Post, repeat the process for the second Post.

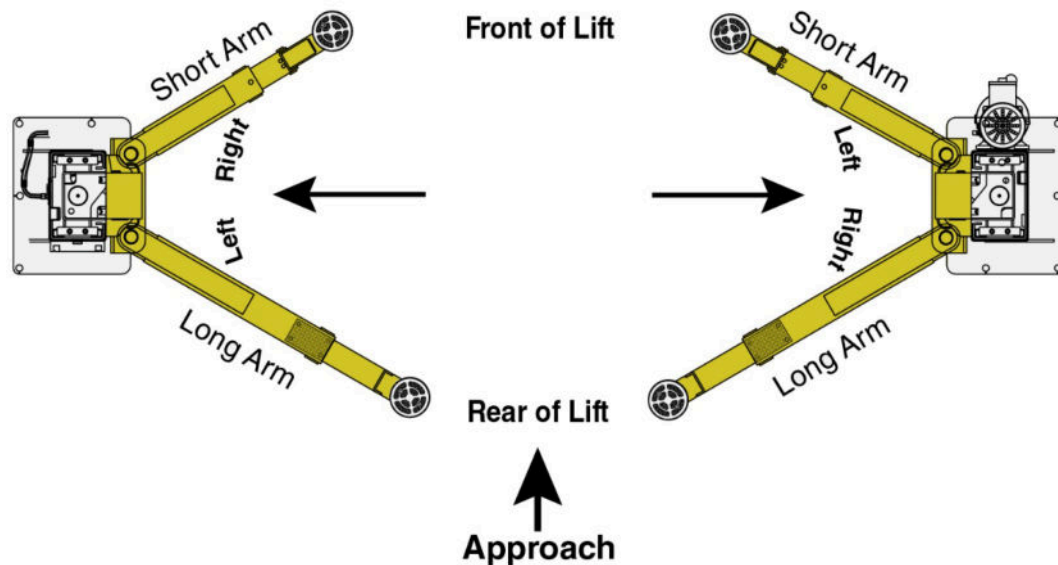

Installing the Lift Arms into the Lift Head Assemblies:

- ⚠ **WARNING** Verify the Lift Head is securely engaged on a lower Safety Lock and the downward motion of the Lift Head is blocked by a jack stand or equivalent.
- ⚠ **CAUTION** The Lift Head and Lift Arms are heavy. Use a forklift or shop crane and exercise caution when raising the Lift Head to a lower locking position to avoid injury.

1. Retrieve the four Lift Arm Assemblies and Pivot Pins. Position one short and one long Lift Arm Assembly near each Post.
2. Using a Forklift or Shop Crane, raise the desired Lift Head to a secured, lower locking position.

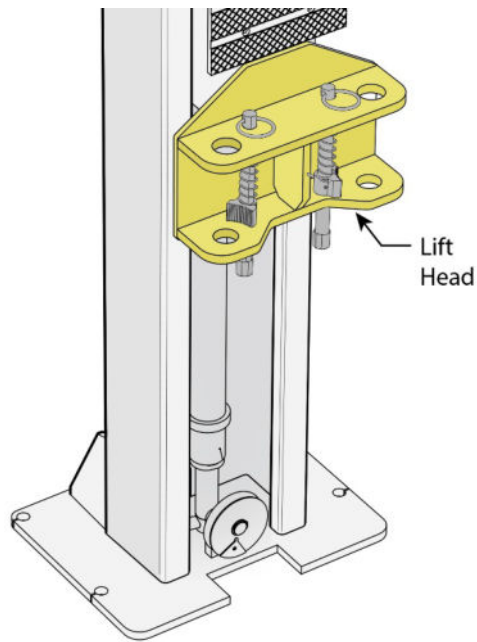

3. Insert the first Lift Arm into the Lift Head assembly, aligning the gear on the Lift Arm with the corresponding gear on the Lift Head.

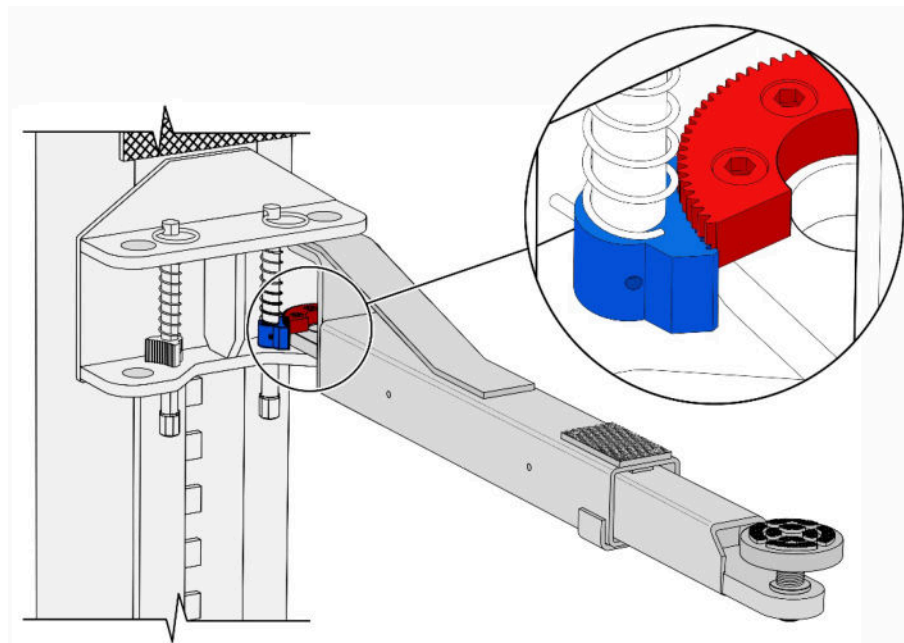

Illustrations not to scale. Some components removed for clarity.

4. Insert the Pivot Pin through both the Lift Head and Lift Arm.

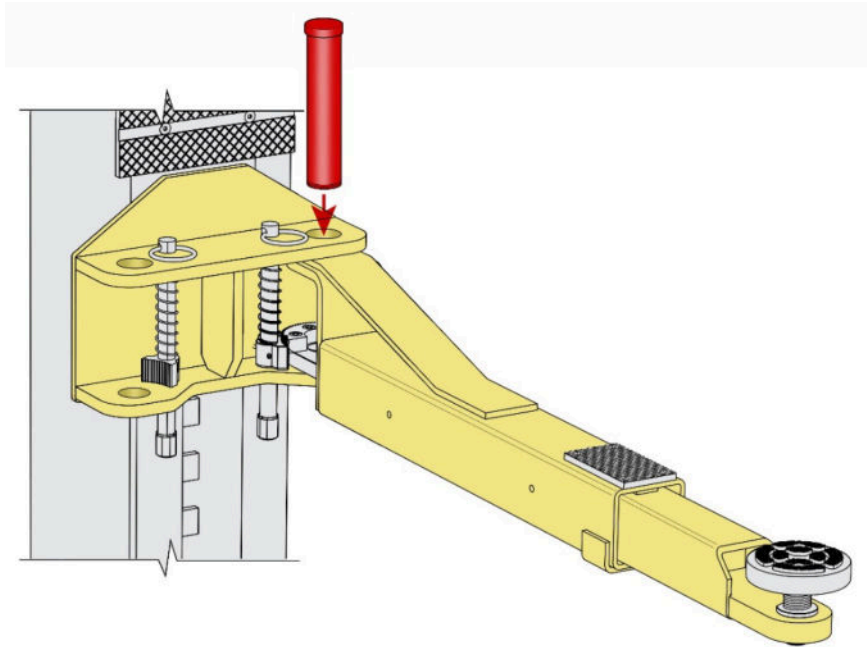

5. Secure the Pivot Pin from the underside of the Lift Arm with the Retaining Clip, using circlip pliers.

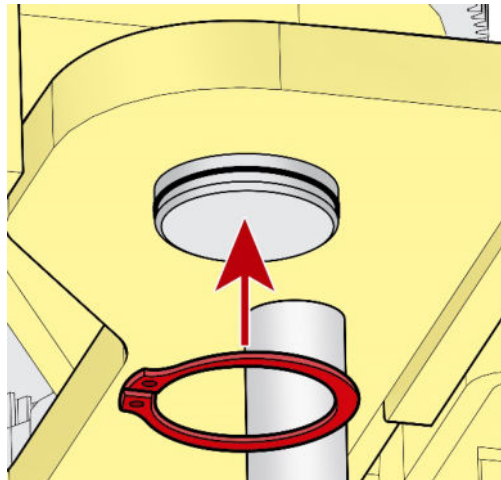

6. Repeat steps 1-4 for the three remaining Lift Arms until all four Lift Arms are securely mounted to the Lift Head Assemblies.

⚠ WARNING Verify that the Arm Restraint Gears and the Gear Stops are meshing and stay in place when up to 150 pounds of lateral force is applied before putting the Lift into normal operation.

⚠ DANGER Each Lift Arm Assembly **must** be inspected and adjusted as required before each use. Do **not** operate the Lift if any of the four Lift Arm restraint systems are not functioning correctly. Replace any damaged components with approved replacement parts only.

Leveling

Before operating the Lift, verify the Lift Posts are straight and the Lift Arms are level.

- **Lift Posts:** Verify the Lift Posts are perpendicular to the ground and parallel to the opposite Lift Post. The Posts **must** be the same distance apart at the top and at the bottom, and the Overhead Assembly **must** be the same height at both Posts.

To confirm that the Posts are both parallel to each other and perpendicular to the ground, swing the Lift Arms out of the way and measure the distance between the two Posts six inches below the upper Overhead Assembly and one foot off the ground.

- The two measurements (**A** and **B** in the illustration below) must be the same.
- Next, measure the distance from the bottom edge of the Overhead Assembly on both sides (**C** and **D** in the illustration below). This will ensure that the Overhead Assembly is parallel to the ground.

If the Posts are not straight, shim them as necessary.

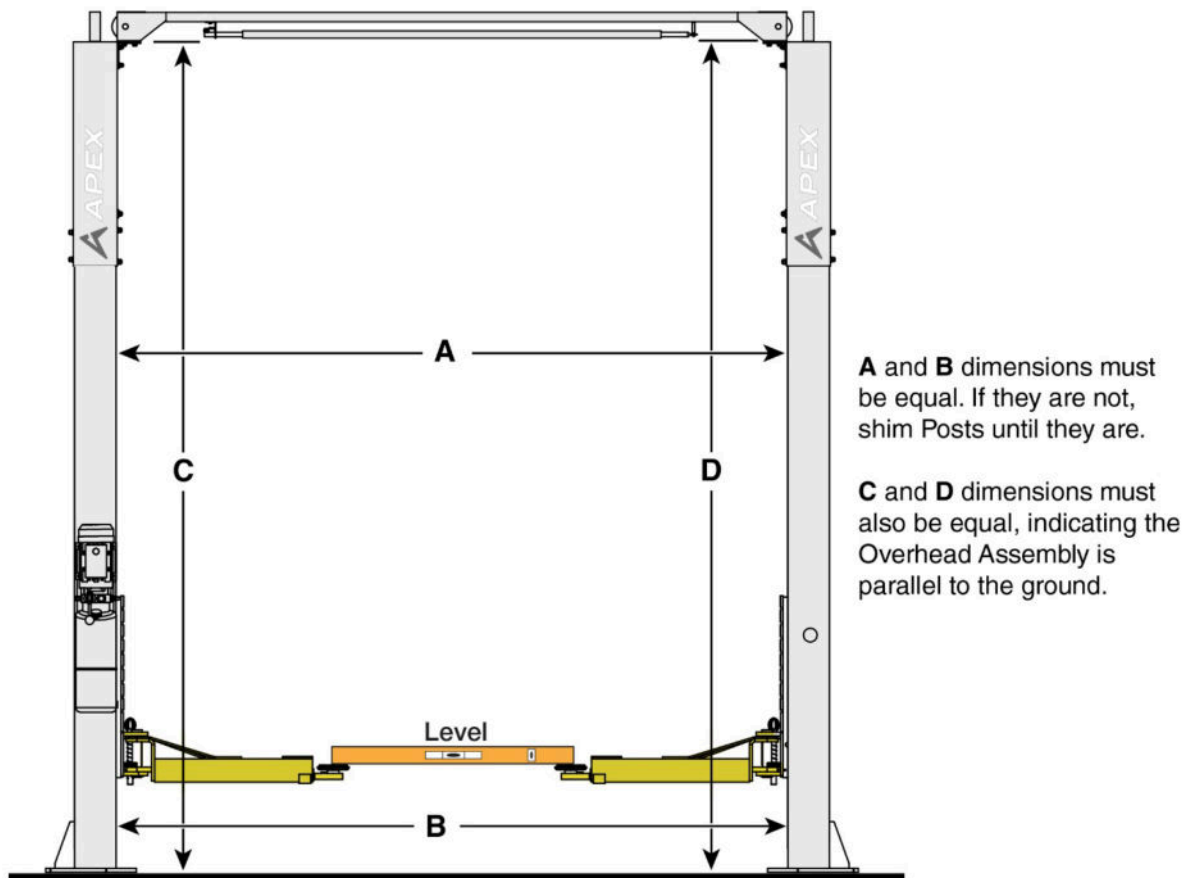

CAUTION

If the Lift Posts are not straight or the Lift Arms are not level, this is a safety risk. Any vehicle put on the Lift will be less secure and could fall, causing serious personal injury and damage to the vehicle and the Lift.

- **Lift Arms:** Once the Lift Posts are straight, check the Lift Arms for level. Raise the arms to the first locking position and put a level across the pads as shown in the illustration below.

Raise the Lift Heads slightly, still within the same Safety Lock window, and check the level again.

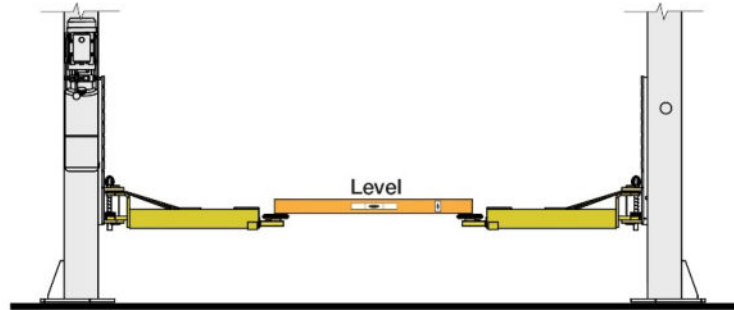

Adjust the Equalizing Cables as necessary by first determining which Lift Arm is low. Then adjust the Locking Nuts where the cable attaches at the bottom of that Lift Head. See illustration below.

- First loosen the second Locking Nut.
- Tighten the first Locking Nut, raising the Lift Head until the Lift Arms are level.
- Securely tighten the second Locking Nut and re-check the level.
- Continue this procedure until a level condition is achieved.

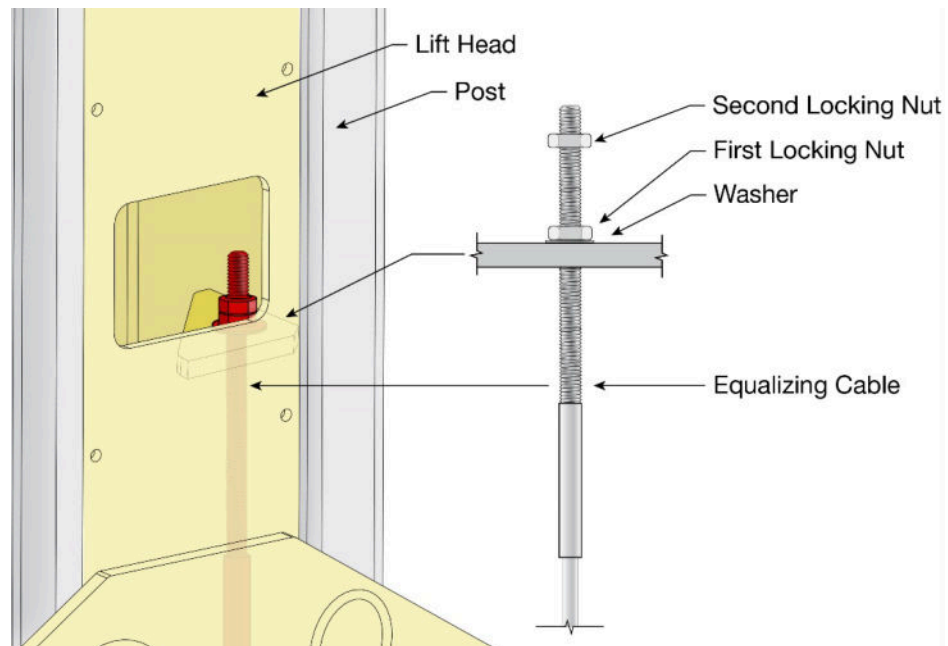

Once the Lift Arms are level and the Locking Nuts securely tightened, raise the Lift and listen for the Lift Head Safety Locks hitting the Safety Lock Weldments within each Post (there will be a distinct “thump” sound). These “thumps” from each side should be simultaneous or close to it.

- Re-install the Lift Head Covers that were removed earlier.

NOTICE If the Anchors have not yet been torqued, they can be torqued to (85 – 95 ft lb.) once the final leveling is complete.

Contacting the Electrician

As mentioned previously, there are installation tasks that require a licensed electrician.

⚠ DANGER All wiring **must** be performed by a licensed electrician in accordance with all applicable national and local electrical codes.

The electrician needs to:

- **Connect to power.** The Power Unit comes with a pigtail for wiring to a power source. Have the electrician connect a power cord with a plug to the electrical box on the Lift (for connection to a power outlet) or have them wire it directly into the electrical system at the chosen Lift location.
- **Connect the Limit Switch to the Power Unit.** The Limit Switch (which is next to the Safety Shutoff Bar on the underside of the Overhead Assembly) must be wired to the Power Unit. The necessary wiring is included with the Lift.
- **Install a Power Disconnect Switch.** A Power Disconnect Switch ensures that power to the Lift can be quickly and completely interrupted in the event of an electrical circuit fault, emergency, or when equipment is undergoing service or maintenance. The Power Disconnect Switch must be placed within the sight and easy reach of the Lift operator. Refer to **Installing a Power Disconnect Switch** for more information.
- **Install a Thermal Disconnect Switch.** A Thermal Disconnect Switch ensures the equipment shuts down in the event of an overload or an overheated motor. Refer to **Installing a Thermal Disconnect Switch** for more information.

These installation tasks are described in detail in the following sections.

The electrician is responsible for providing the following:

- A power cord and appropriate 220 VAC plug for connecting to an appropriate power outlet, or the items required to connect directly to the facility's power system.
- A Power Disconnect Switch.
- A Thermal Disconnect Switch, *if required by local electrical codes.*

Electrical Information

⚠ DANGER All wiring **must** be performed by a licensed electrician in accordance with all applicable national and local electrical codes. Do not perform any maintenance until the main electrical power has been disconnected from the Lift and cannot be re-energized until all procedures are complete.

Important electrical information:

- An improper electrical installation can damage the Power Unit's Motor and is not covered by the warranty.
- The Lift uses electrical energy. If the location where the Lift is installed has Lockout/Tagout policies, make sure to implement them after connecting to a power source.
- Use a separate circuit breaker for each Power Unit.
- Protect each circuit with a time delay fuse or circuit breaker.
 - For a 208 to 230 VAC, **single phase** circuit, protect with a 25 Amp time delay fuse or circuit breaker.

Wiring the Limit Switch

This section describes how to wire the Limit Switch. *Installing the Limit Switch* is described in [Installing the Limit Switch](#).

Refer to the diagrams in [Wiring Diagrams](#) for detailed Limit Switch wiring information.

⚠ DANGER All wiring must be performed by a licensed electrician in accordance with all applicable national and local electrical codes.

⚠ DANGER Do not allow any electrical work on the Lift to be done until the main electrical power has been disconnected and cannot be re-energized until all procedures are complete.

⚠ WARNING Keep all wiring secured within the Hose/Cable Retainers built into the Lift. Verify all wiring and hydraulic hoses are clear of all moving parts and pinch points.

Wiring the Limit Switch to the Lift:

1. Verify the Limit Switch on the Overhead Assembly is on the same side as the Power Unit. If not, the Overhead Assembly must be removed and rotated to place the Limit Switch on the Power Unit side.
2. Locate the Limit Switch Cable supplied with the Lift.
3. **On the Overhead Assembly**, connect one end of the Limit Switch Cable to the Limit Switch. Refer to [Wiring Diagrams](#) for wiring information.
4. Route the cable from the Limit Switch up through the nearest hole in the Overhead Assembly, through the Hose/Cable retainers on the Overhead Assembly and down through the Cable Routing Channel inside the Power Side Post, out the grommet in the side of the Post near the Power Unit, and over to the Electrical Box on the Power Unit. All wiring within the Overhead Assembly should be straight, with no slack, and secured within the retainers—so it does not come in contact with the moving Cables.

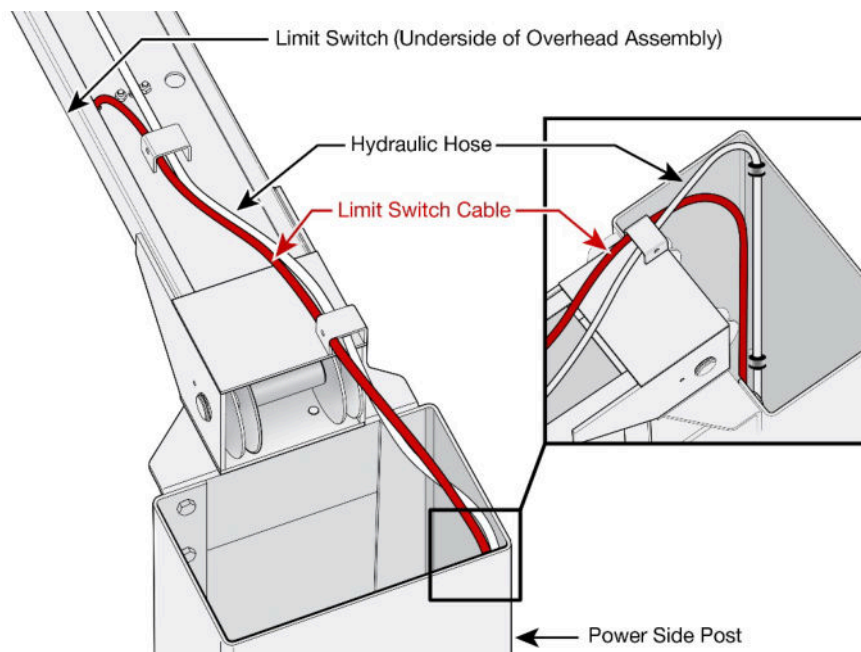

Illustration not to scale. Not all components shown.

5. **On the Power Unit**, open the Electrical Box and connect the Limit Switch wiring as per the instructions found in **Connecting the Power Unit**.

IMPORTANT. Verify that all cables and hoses are routed securely through the Hose/Cable Retainers within each Post, and across the Overhead Assembly, to avoid moving components and pinch points.

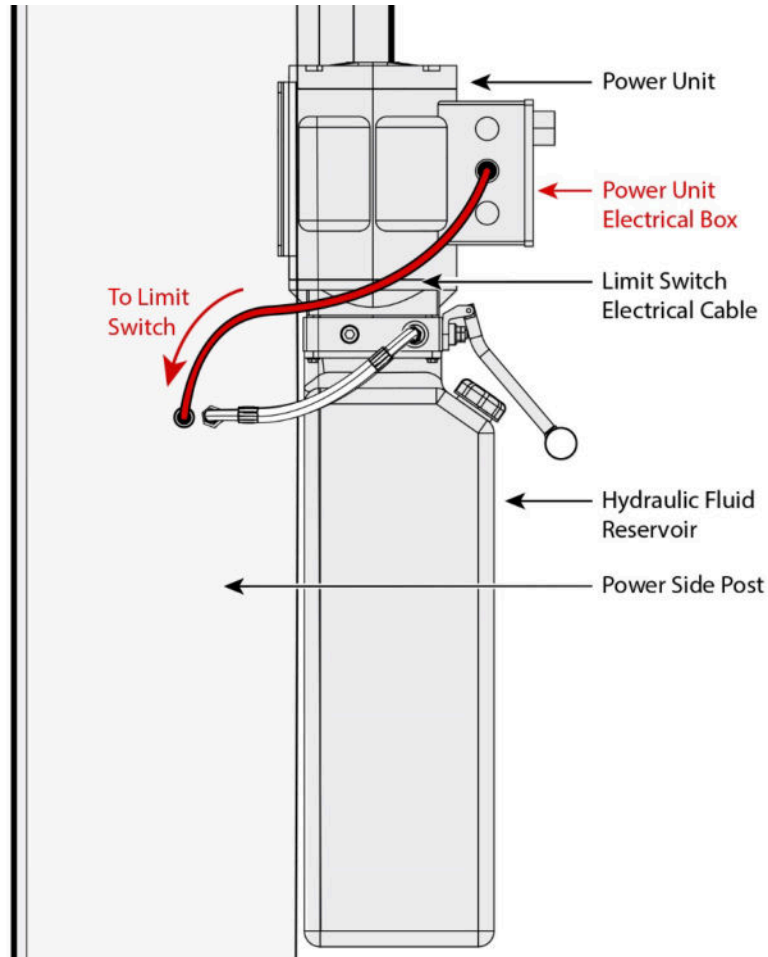

Illustration not to scale. Power Units may vary in appearance.

Connecting the Power Unit

The Power Unit and Limit Switch must be connected to an appropriate power source.

⚠ DANGER All wiring **must** be performed by a licensed electrician. Do not perform any maintenance or installation on the Lift without first ensuring that the main electrical power has been disconnected from the Lift and cannot be re-energized until all procedures are complete. The Lift uses electrical energy. If the location where the Lift is installed has Lockout/Tagout policies, make sure to implement them after connecting to a power source.

⚠ DANGER Inform the electrician that all electrical work **must** conform to applicable local, state, and federal codes, rules, and regulations, such as state and federal OSHA regulations and electrical codes.

The AL10C Lift is available with the following Power Unit:

- **220 VAC, 60 Hz, 1 Phase.** 220 VAC, for North American countries (U.S., Mexico, Canada).

NOTICE 110 VAC Power Units are currently **not** available for AL10C Series Lifts.





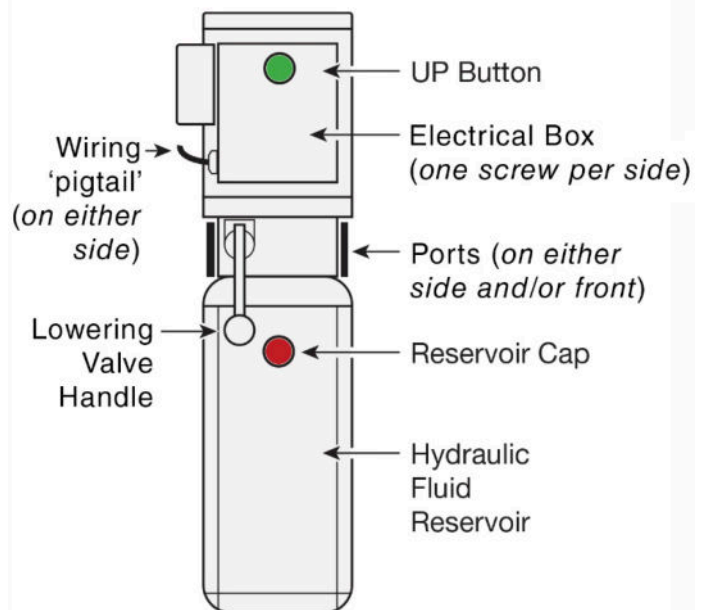





The following illustration is a front view of a typical Power Unit.

NOTICE Wiring information is either on the outside of the Power Unit, under the Electrical Box, or inside the cover of the Electrical Box. The electrician must use that wiring information to wire the Power Unit to the power source. See **Wiring Diagrams** for more information.



Hydraulic System Warnings

Before applying power to the hydraulic system note the following warnings:

-  **DANGER** Failure to observe these warnings can result in serious personal injury, including, in rare cases, death.
-  **DANGER** The Hydraulic Hoses and connections **must** be inspected before any attempt to raise a vehicle is made.
-  **DANGER** Verify that all hydraulic hose connections and fittings, including unused auxiliary port plugs on the Power Unit, the Cylinders and anywhere else in the Hydraulic System are tightened.
-  **DANGER** The Power Unit is a hydraulic pump capable of developing pressures in excess of 3,000 psi (345 BAR). A pressure relief valve is used to set the pressure at the desired level. Tampering with, adjusting, modifying, or removing the relief valve is extremely dangerous and is not permitted. Only trained hydraulics technicians should adjust the relief valve, using calibrated hydraulic pressure gauges to ensure the proper pressure setting is achieved.
-  **DANGER** Changes to the output pressure may render the power unit incompatible with pressure limitations of other components in the hydraulic circuit. This may cause catastrophic failure of those components, and could result in property damage, serious personal injury, or death.
-  **DANGER** The hydraulic system contains high pressure which, if suddenly released, can cause severe injury or death.
-  **WARNING** Do **not** attempt to connect or disconnect hydraulic hoses while the equipment is loaded or while a vehicle is on the Lift, or the hydraulic system is under pressure.
-  **WARNING** Keep bare hands away from hydraulic fluid. Always wear gloves when handling hydraulic fluid, cylinders or hydraulic hoses.
-  **WARNING** When handling hydraulic fluid, always observe the safety instructions from the manufacturer.
-  **WARNING** **Always** promptly clean any hydraulic fluid spills. If a leak is the source of the spill, lockout the Lift to prevent use until the hydraulic system is repaired.

Preparing the Power Unit:

1. Have the electrician locate the pigtail exiting the electrical junction box on the Power Unit.
2. Open the junction box, remove the pigtail, and then either:
 - Wire the Power Unit directly into the facility's electrical system—protected by an appropriate circuit breaker.
 - Wire a power cord (with appropriate plug) *inside the Electrical Box* to the wiring that was connected to the pigtail.
3. Fill the hydraulic fluid reservoir with approved hydraulic fluid (not included with the Lift).

The reservoir holds **≈3.2 gallons (12 Liters)**.

Approved hydraulic fluids are any general-purpose ISO-32, ISO-46, or ISO-68 hydraulic oil or approved automatic transmission fluids such as Dexron VI, Mercon V, Mercon LV, Shell Tellus S4 / S3 / S2, or any synthetic multi-vehicle automatic transmission fluid.

 **WARNING** Running the Power Unit without hydraulic fluid will cause damage to the unit.

 **DANGER** **Risk of explosion:** This equipment has internal arcing or parts that may spark and should not be exposed to flammable vapors. The Power Unit's motor must not be located in a recessed area or below floor level. Never expose the motor to rain or other damp environments. Damage to the motor caused by water is not covered by the warranty.

Installing a Power Disconnect Switch

⚠ WARNING A Power Disconnect Switch is *not* provided with the AL10C Lift.

A Power Disconnect Switch is a National Electrical Code (NEC) requirement designed to allow the operator of the Lift to interrupt the main electrical power in the event of an emergency or circuit fault, or when the equipment is undergoing service or maintenance.

Make sure to install a Power Disconnect Switch that is properly rated for the incoming power source.

The Power Disconnect Switch must be readily accessible and installed so that it is within easy reach of the operator or in their line of sight. The Power Disconnect Switch must be clearly marked to indicate its purpose.

The illustration to the right details a Power Disconnect Switch located between the Lift's power source and the Power Unit. A quick flip of the switch immediately cuts power to the Lift.

⚠ DANGER A Power Disconnect Switch *must* be installed by a licensed electrician in accordance with local and national electrical codes.

Ensure that the electrician selects a **UL-listed** Power Disconnect Switch.

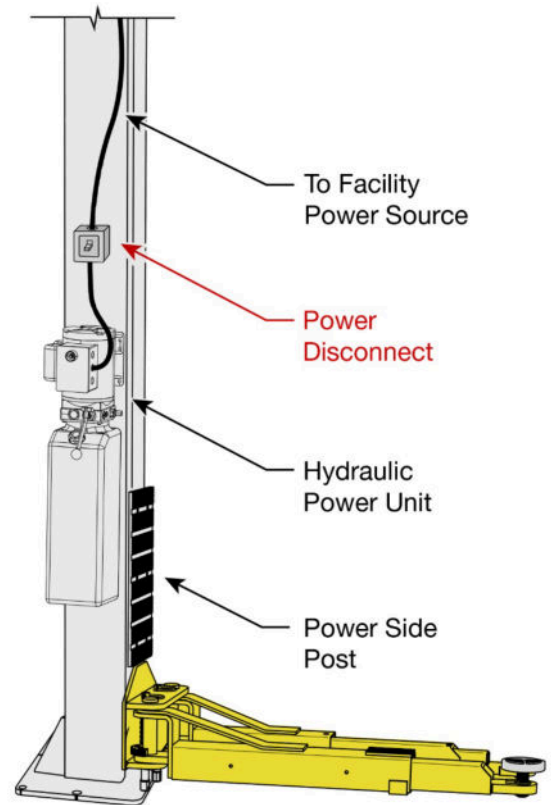

Installing a Thermal Disconnect Switch

The Power Unit supplied with the AL10C Lift *does not* include thermal overload protection. Under NEC 430, UL 201, and CSA C22.2 No. 68, intermittent duty motors are not required to include thermal protection. Local electrical codes may vary, and other requirements may exist that the installing electrician will address, if required.

⚠ DANGER A licensed electrician must install a thermal disconnect if required by local electrical codes. Do not perform *any* maintenance or installation on the Lift without first verifying that the main electrical power has been disconnected from the Lift and *cannot* be re-energized until all procedures are complete.

Lubricating the Lift

Lubricate the following parts of the Lift with white lithium grease or equivalent:

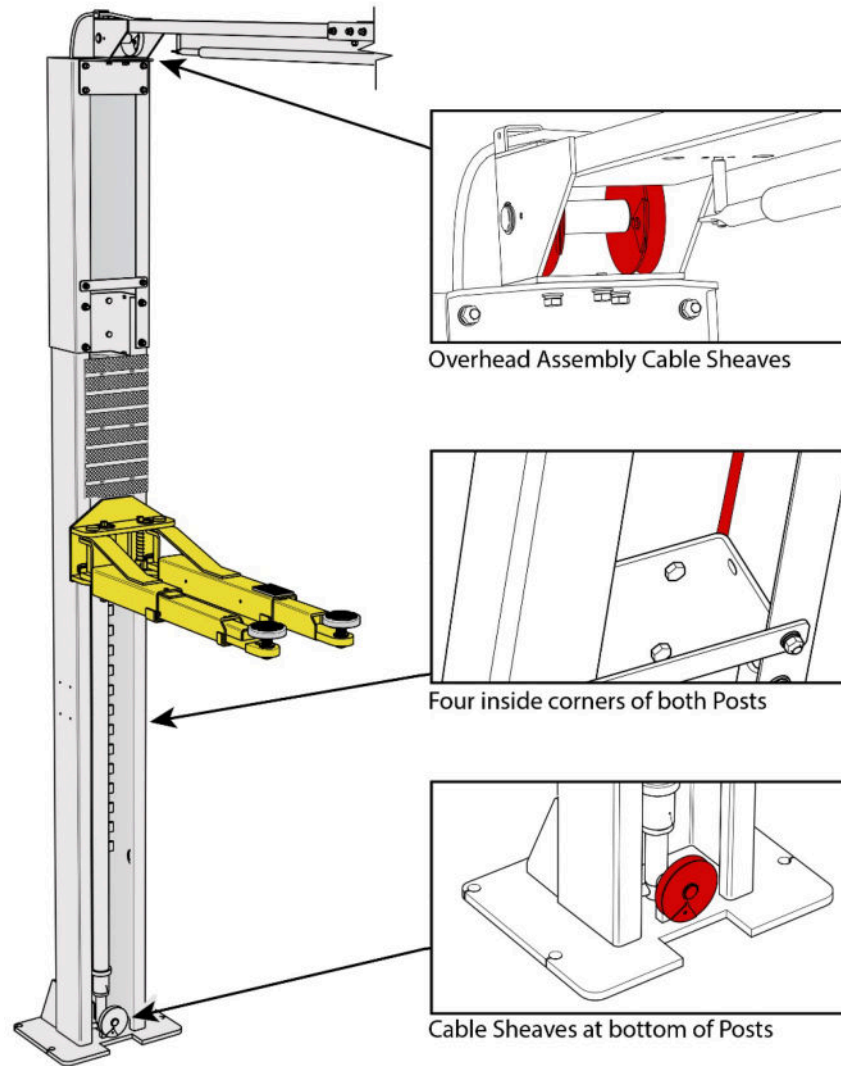

⚠ WARNING BendPak does not supply lubrication products with the AL10C Lift. **Always** refer to the Material Safety Data Sheet (MSDS), available from the lubricant supplier or manufacturer, for safe handling and disposal information.

Review Final Checklist Before Operation

Make sure the following steps have been completed before putting the Lift into normal operation:

- Review the **Installation Checklist** and verify all steps have been performed.
- Make sure the Power Unit is getting power.
- Check the Hydraulic Fluid Reservoir. It must be filled with an approved hydraulic fluid or automatic transmission fluid. **The motor can be damaged by running it without enough fluid.**
- Check the Hydraulic System for leaks. Verify all hydraulic hose connections, hydraulic fittings, and auxiliary port plugs on the Lift and Power Unit are tight and not leaking.

- Make sure both Posts are properly plumbed, shimmed, and stable.
- Check all Anchor Bolts to ensure they are correctly torqued.
- Lubricate all Cable Sheaves and the inside of the Posts where the Slide Blocks move.
- Verify all Cables are properly positioned in their retainers.
- Verify both Safety Locks are connected and working normally.
- Verify the Cylinder Clamps are secured on the Hydraulic Cylinders just above the Lift Head.

⚠ WARNING Never operate the Lift without the Cylinder Clamps securely in place.

- Check to ensure that the Limit Switch is functioning properly—by pressing up on the Safety Shutoff Bar while attempting to raise the Lift (without a vehicle on it). If the Limit Switch is working correctly, the Lift will not raise during the test.

If the Limit Switch is not functioning correctly, and the Lift rises while pressing up on the Safety Shutoff Bar and pressing the UP button on the Power Unit at the same time, refer to **Wiring Diagrams** for proper wiring information.

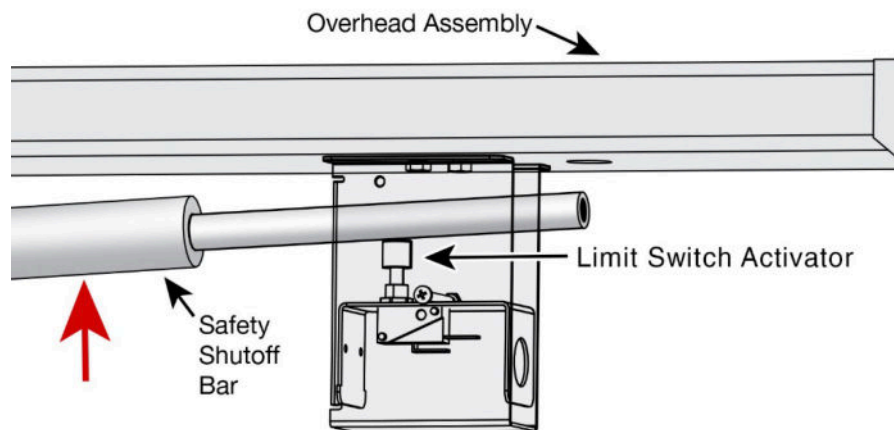

- Make sure an Operational Test has been performed. See the following page.

Leave the Manual with the Owner/Operator

Make sure to leave the *Installation and Operation Manual* with the owner/operator so that it is available to everyone who uses the Lift.



Performing an Operational Test

Before putting the Lift into normal operation, BendPak recommends raising and lowering it several times with a typical vehicle on it. This will help establish a feel for how to operate the controls and will also work any residual air out of the Hydraulic System (sometimes called “bleeding” the system).

⚠ DANGER Automotive Lifts are dangerous tools when used by inexperienced or impaired technicians. Hearing the words “automotive lift,” should automatically register that lifting a vehicle is a serious endeavor with life-threatening risks if mandatory lifting precautions are ignored.

During the Operational Test, check for proper installation and operation. Do not raise any additional vehicles until a thorough Operational Test has been done with a typical vehicle.

⚠ WARNING Never raise a vehicle whose weight exceeds the rated capacity of the Lift. Do not leave the controls until the Lift is engaged on its Safety Locks. Only trained personnel should raise or lower the Lift.

To perform an Operational Test:

1. Make sure that all steps in **Review Final Checklist before Operation** have been covered before proceeding any further.
2. Follow the instructions in **Raising a Vehicle** and **Lowering a Vehicle** to safely raise and lower a vehicle on the Lift.

⚠ DANGER Follow the instructions carefully when it comes to locating and contacting the manufacturer’s recommended lifting points on the underside of a vehicle. If not, the vehicle could become unstable and fall, which could damage the vehicle and the Lift, and injure or possibly kill anyone under the vehicle.

3. Before lifting a vehicle, adjust the Lift Arms so that the Lift Pads are directly under the lifting points for the vehicle being raised. If necessary, use the included 2.5 in. (63 mm) Auxiliary Adapters. Optional 5 in. (125 mm) adapters are also available.
4. Press the **Up** button to raise the Lift Arms until **just before** the point where the Lift Pads contact the Lifting Points on the vehicle.
5. Check the Arm Restraint Gears on all four Lift Arm Assemblies to verify they are engaged. If they are not engaged, move the Lift Arms back and forth until they engage.
6. Continue to raise the Lift until the tires of the vehicle are a few inches off the ground.
7. Verify that all four Lift Pads are making solid contact with all four vehicle lifting points.
If any of the Lift Pads are **not** making solid contact with the vehicle lifting points, carefully lower the Lift and start over again. The Lift Pads **must** make solid contact with all four of the vehicle’s lifting points before any service work is performed.
8. Raise the vehicle approximately three feet off the ground, then release the **Up** button. Pull down on the red Safety Release Handle on the Power Unit side. The handle is located just under the Lift Arm. Next, on the opposite Post, pull down on the second red Safety Release Handle. See *illustration below*.

NOTICE Residual air in the Hydraulic System can cause the Lift to shake, move erratically, or squeak. This is normal when first using the Lift and will stop as the Hydraulic System self-bleeds.

9. Wait for one minute.

 **WARNING** The Power Unit is not a constant duty motor. ***It cannot run continuously.***

10. Repeat the process, this time raising the Lift, engaging it on a Safety Lock position, taking it off the Safety Lock position, and then lowering it back down to the ground.
11. If the Lift is working without shaking, moving erratically, or squeaking, there is no need to repeat the procedure. If the Lift is still shaking, moving erratically, or squeaking, repeat the procedure one more time. If this issue continues, refer to **Troubleshooting** for assistance.
12. When the Lift is on the ground and the vehicle is on all four tires, move the four Lift Arms to their full drive-through positions, then drive the vehicle out.
13. With no vehicle on the Lift Arms, press and hold the **Up** button on the Power Unit.
14. Have another person push up the Safety Shutoff Bar until it triggers the Limit Switch.

If the Lift Arms do not stop rising when the Limit Switch is triggered, the Limit Switch is either not installed correctly or not wired correctly. Return to the sections in this manual where installation and wiring of the Limit Switch is described to identify and correct the issue.

 **CAUTION** Do not put the Lift into normal operation until it has been confirmed that triggering the Limit Switch stops the Lift Arms from rising.

Operation

This section describes how to operate the AL10C Lift.

Lift Operation Safety Rules

 **DANGER** Automotive Lifts are dangerous tools when used by inexperienced or impaired technicians. Hearing the words “automotive lift,” should automatically register that lifting a vehicle is a serious endeavor with life-threatening risks if mandatory lifting precautions are ignored.

 **DANGER** The safety of the Lift operator depends on reading, understanding, and implementing these Safety Rules. Do not skip over them. Read them carefully and follow them.

Do the following **before** raising or lowering a vehicle on the Lift:

Check the Lift. A complete inspection of the Lift is required before use. Check the hydraulic system for loose connections, including Hydraulic Fittings, Hydraulic Hoses, and any Auxiliary Port Plugs. Check the Lift for any missing, heavily worn, or damaged parts. Do not operate the Lift if any issues are found. Instead, take the Lift out of service, contact the dealer, email support@bendpak.com, or call **(888) 856-5820**.

- **Check the area.** Keep the area around the Lift clean and free of obstructions or anything that could cause a problem for the Lift. Do not forget to check **above** the Lift. If any obstruction is found, move it out of the way. Do not allow any people or animals within 30 ft. (9.1 m) of the Lift while it is in motion.
- **Check the operators.** Make sure that everyone who is going to operate the Lift has been trained in its use, has read the labels on the unit, and thoroughly read the manual and understands how the equipment works. Do not allow children to operate the Lift. Do not allow anyone under the influence of drugs or alcohol to operate the Lift.
- **Check for safety.** Make sure everyone who is going to be walking near the Lift is aware of its presence and takes appropriate safety measures. Only support vehicles by the Lift Arms. **When raising a vehicle on the Lift, do not leave the area until the Lift is securely positioned on its Safety Locks.** When lowering the Lift, do not leave it until it is safely on the ground.
- **Check the vehicle.** Never exceed the Lift’s weight rating. Do not allow anyone to be inside a vehicle while it is on the Lift. Make sure the vehicle is not overbalanced on either end. Make sure the operator knows the manufacturer’s recommended lifting points for the vehicle. Never raise just one side, one corner, or one end of a vehicle.

 **WARNING** Always use care while around the Lift. When it is in a lowered position, be careful not to trip over it. When it is raised, be careful to avoid the Lift Arms or the vehicle. **When raising or lowering a vehicle, keep all people, animals, and objects at least 30 ft. (9.1 m) away from the Lift.**

 **WARNING** Never allow the operator or anyone else under a raised vehicle unless the Lift is securely engaged on its Safety Locks and the vehicle is stable on the Lift.

About Lifting Points, Adapters, and Auxiliary Adapters

An important point to keep in mind when using a frame-engaging Lift is that the raised vehicle must be balanced on the four Lift Arms. If the vehicle is not balanced, it is more likely to become unstable and slide off the Lift, possibly damaging the Lift, the vehicle, and anything or anyone under the Lift.

⚠ WARNING All four Lift Arms must be used when raising a vehicle. Never use just one, two, or three Lift Arms to raise a vehicle as it will be unstable and could slip off the Lift, possibly damaging the Lift, the vehicle, and injuring anyone under it.



To balance a vehicle on a frame-engaging Lift, the Lift Pads must contact the vehicle on the manufacturer's recommended Lifting Points. When raising a vehicle by its correct Lifting Points, the vehicle is balanced.

NOTICE The manufacturers' recommended Lifting Points do not take into consideration any major changes that might have been made to the vehicle. If the motor is removed, for instance, or there is heavy weight in the trunk, the vehicle's Lifting Points will not be the best balancing points.

Some vehicles have indicators on the underside that identify the manufacturer's Lifting Points, but many do not.

The best approach is to find the vehicle in the guide (*Vehicle Lifting Points for Frame Engaging Lifts*) available from ALI, or by contacting the manufacturer of the vehicle. This guide also includes a page of safe lifting suggestions, which everyone who uses the Lift should read.

Lifting it Right: A Safety Manual from the Automotive Lift Institute is recommended reading and includes a wide variety of information about Lifts and how to use them safely.

⚠ DANGER **Never** place Contact Pads on non-approved, non-load bearing Sill Covers or Side Skirts!



Optional Accessories

IMPORTANT! The Optional Adapters listed below are **not** included with the AL10C Lift.

Visit bendpak.com for ordering information.

- **Four Tall Auxiliary Adapters – 5 in. (125 mm) -** Extend the height of the standard Auxiliary Adapters, to accommodate higher clearance vehicles.
- **Four Frame Cradle Adapters –** Required for use when lifting trucks, vans or other frame vehicles that require additional stability.

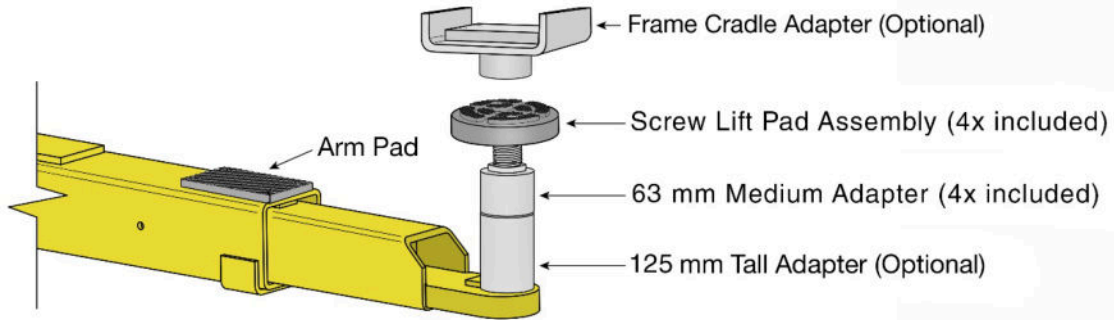

SKU	OPTIONS	DESCRIPTION
5210573	Frame Cradle Adapter / 50mm Pin / Set of 4	2-Post Frame Cradle Pad / 50mm / Set of 4
5210535	Tall Adapter / 50mm Pin / Set of 4	2-Post Stacking Truck/Van Adapter / 125mm / 50mm Pin / Set of 4
SKU	REPLACEMENTS	DESCRIPTION
5210536	63 mm Medium Adapter / Set of 4	2-Post Stacking Truck/Van Adapter / 63mm / 50mm Pin / Set of 4
5216333	Screw Lift Pad Assembly / Ea.	2-Post Telescoping Screw Pad / 50mm Pin / Polyurethane Tuf-Pad / Ea.
5210511	Replacement Lift Pads / Set of 4	Replacement Polyurethane 2-Post Lift Pad / AL Series / Slip Over / Set of 4
5210512	Replacement Arm Pads / Set of 2	Arm Topper Lift Pad / Fits Long Arms / AL Series / Set of 4

⚠ WARNING Auxiliary Adapters can be stacked, but only up to 7.5 in. (188 mm). If they are stacked above 7.5 in. (188 mm), the vehicle could become unstable and slip off the Lift, possibly damaging the Lift, damaging the vehicle, and injuring anyone under it.

⚠ WARNING Use the correct adapters. Do not attempt to lift trucks or other frame type vehicles with standard rubber Contact Pads.

⚠ WARNING Never use the Lift with missing or damaged rubber Contact Pads. Always replace Rubber Contact Pads when worn or damaged.

Visit BendPak.com for current accessories and replacement parts information at **(800) 253-2363** then follow the prompts. Please have the model and serial number of the Lift available.

Raising a Vehicle

This section describes how to raise a vehicle on the AL10C Two-Post Lift.

⚠ WARNING Never raise a vehicle whose weight exceeds the rated capacity of the Lift. Do not leave the controls until the Lift is engaged on a Safety Lock position or fully lowered. Only trained personnel should raise and lower the Lift.

⚠ WARNING Always stay within the *Safe Operator Area* when using the Lift. Refer to the illustration below. The safe operator area will keep the operator clear of crushing, shear, and pinch points while providing an unobstructed line of sight to the vehicle, as well as access to the Lift controls. Personnel near the Lift but outside of the *Safe Operator Area* should be moved clear of the lift by a minimum of 30 ft. (9 m).

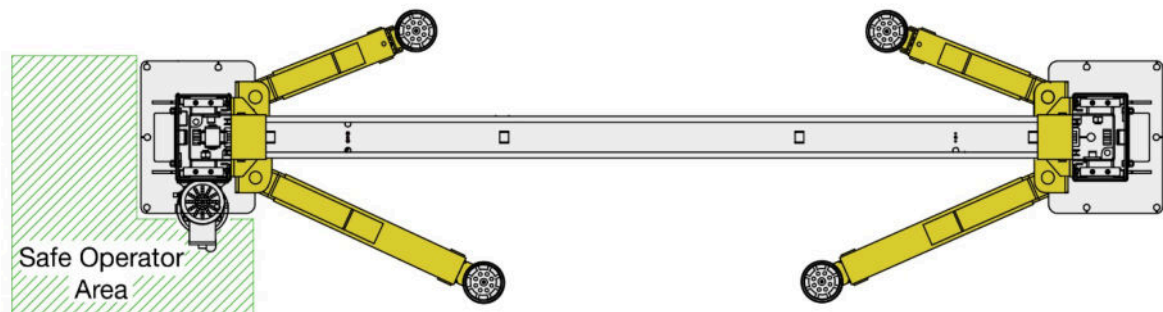

To raise a Vehicle:

1. Verify all four Lift Arms are on the ground and in their full drive-through positions and all personnel are clear of the service bay.
2. Check under the vehicle being raised for the type of frame and then put the most appropriate Pads/Adapters on the Lift Arms.

When lifting a sedan or a vehicle with a unibody construction, a Screw Lift Pad is generally the best choice. When lifting an SUV, truck, or other vehicle with a frame construction, an (optional) Frame Cradle Pad is required.

⚠ WARNING Always use the Pad/Adapter type best suited for the vehicle being raised. Using the wrong Adapter type could cause the vehicle to become unstable on the Lift.

3. Drive the vehicle into the service bay.

⚠ CAUTION When driving a vehicle into position, stay to the middle of the area between the Posts. Hitting a Lift Arm or any other portion of the Lift could damage the vehicle and/or the Lift.

4. When the vehicle is correctly positioned, put it in park, engage the parking brake, and turn off the motor.

If the vehicle is a manual transmission, put it into first gear.

Driver and passengers must all exit the vehicle prior to operating the Lift. Open the doors carefully.

5. Locate the manufacturer's recommended Lifting Points for the vehicle being raised.

When unsure about the correct Lifting Points, consult *Vehicle Lifting Points for Frame Engaging Lifts* or the manufacturer of the vehicle. If there is no copy available, contact ALI (see page 75).

Some vehicles may have the manufacturer's recommended Lift Point locations identified by a triangle mark on the underside of the vehicle. Reference SAE J2184- (Current Edition). On some vehicles, specific Lifting Points are indicated by a label located on the driver's side door jamb.

⚠ WARNING Do not 'eyeball' the best location for the Pad/Adapters. **The manufacturer's recommended Lifting Points must be used**, otherwise the vehicle could become unstable and fall, which could damage the vehicle, damage the Lift, or injure or even kill anyone under the vehicle.

⚠ WARNING Many specialty or modified vehicles or vehicles with unusually short or long wheelbases cannot be raised on a Two-Post Frame Engaging Lift. Contact the vehicle's manufacturer for raising or jacking guidance.

The illustrations below show typical lifting points based on vehicle frame types.

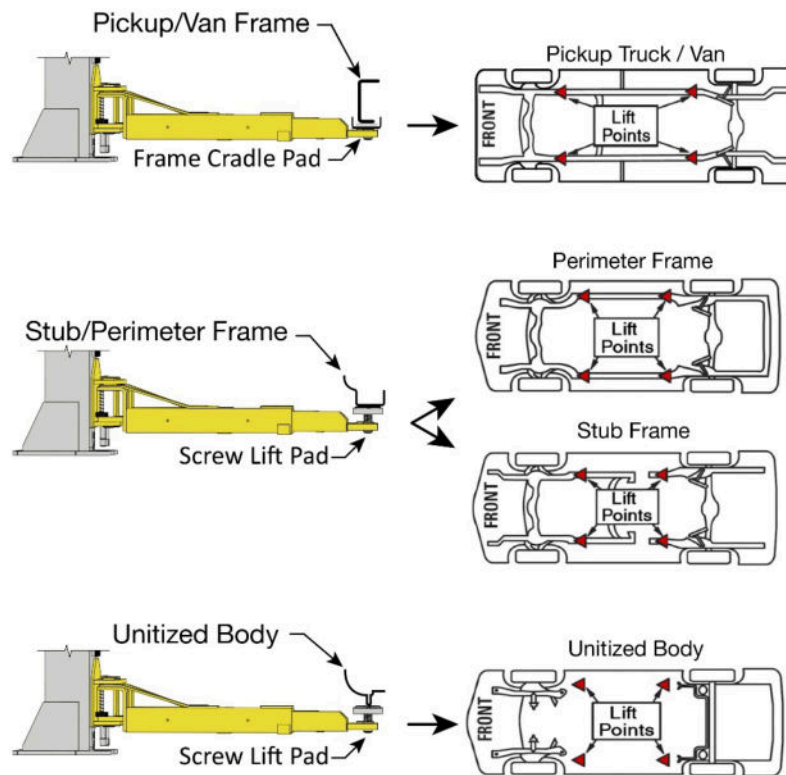

⚠ WARNING Before attempting to lift a vehicle, verify:

- The vehicle's frame is strong enough to support its weight and has not been weakened or compromised by modification, damage, or corrosion.
- The vehicle's individual axle weight does not exceed one-half the Lift capacity.
- All Lift Pads/Adapters are in secure contact with the frame at the vehicle manufacturers' recommended lift points.
- The vehicle is stable on the Lift and the center of gravity has not shifted, causing the vehicle to be off-balance.
- The overhead Shutoff Bar will contact the highest point on the vehicle.

⚠ WARNING Always use safety stands when removing or installing heavy components that may affect the vehicle's center of gravity.

- Adjust the Lift Arms until the Pads/Adapters are **directly under** the lifting points for the vehicle being raised. If necessary, use the included 2.5 in. (63 mm) Auxiliary Adapters for extra height.

Optional 5 in. (125 mm) Adapters are also available. When combined, these Auxiliary Adapters provide up to 7.5 in. (188 mm) of additional reach. See page 54 for more information.



The vehicle's lifting point locations and center of gravity will determine if the Lift is configured in an **asymmetric** or **symmetric** configuration.

In an **asymmetric** configuration the centerline of the vehicle is behind the Lift Posts.

In a **symmetric** configuration the centerline of the vehicle is lined up at the Lift Posts.

Refer to the illustrations below.

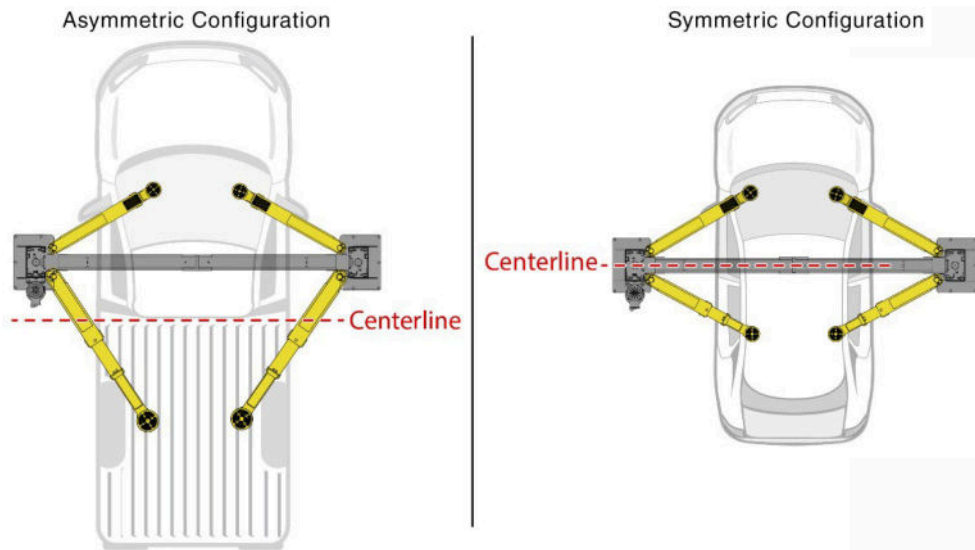

Illustrations for reference only. Not to scale.

- Raise the Lift until **just before** the Pads/Adapters contact the vehicle's lifting points. If necessary, the Lift Pads can be adjusted slightly up and down by rotating them clockwise or counterclockwise.
- Check the Arm Restraint Gears on all four Lift Arms to make sure they are engaged.
If they are not engaged, move the Lift Arms back and forth until they engage.
- Raise the Lift until the tires of the vehicle are a few inches off the ground.
- Verify all four Pads/Adapters are making solid contact with the lifting points.

If any of the Pads/Adapters are **not** making solid contact with the lifting points, carefully lower the Lift and start over again. The Pads/Adapters **must** make solid contact with all vehicle lifting points.

11. Gently rock the vehicle to make sure it is stable and balanced.
 - If the vehicle is **not** stable and balanced, lower the Lift back to the ground and start over.
 - If the vehicle **is** stable and balanced, it can then be raised to the desired height.

⚠ DANGER Do not raise the Lift until it is certain that the vehicle on the Lift is both stable and balanced. If the vehicle is **not** stable and balanced, it could fall, which could damage the vehicle and the Lift, as well as injure or kill anyone under the vehicle.

⚠ WARNING Always keep a line of sight on the Lift. Ensure personnel and objects are always clear of the Lift.

⚠ WARNING Remain clear of the elevated Lift until visual confirmation is made that all Safety Locks are fully and securely engaged.

12. Press and hold the **Up** Button.

13. Listen as the Lift passes the Safety Locks. A “thump” sound should be heard as each side passes by its Safety Lock at approximately the same time.

14. When the vehicle reaches the desired height, go past the next Safety Lock position (a “thump” should be heard as it passes), then release the **Up** Button.

15. *Press and hold* the Lowering Valve Handle, which lowers the Lift onto the Safety Lock position just passed. **Do not pull down on the two red Safety Lock Release Handles**, which are only for lowering the Lift to the ground.

16. When the Lift stops lowering, meaning it is engaged on its Safety Locks, release the Lowering Valve Handle.

Do not leave the Lift controls unless the Lift is engaged on its Safety Locks or fully lowered.

17. Re-check the Pads/Adapters to make sure they are all still making solid contact with the Lifting Points.

18. Verify the Lift is engaged on the **same Safety Lock** on both Posts.

19. Always use jack stands when removing heavy vehicle components (such as engines) that shift the vehicle’s center or gravity.

⚠ DANGER Always ensure that both Safety Locks are engaged. If the Lift Heads are engaged on Safety Locks at two different heights, or only one Safety Lock is engaged, the vehicle could become unbalanced and fall, causing damage, injury, or death.

20. The Lift is now ready for the vehicle to be serviced.

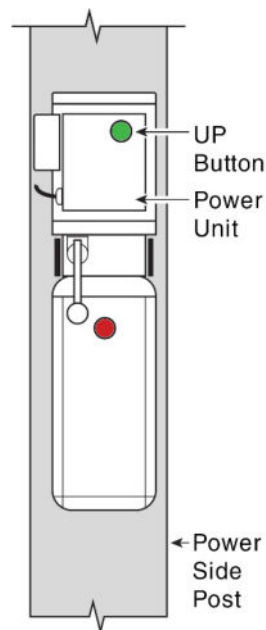

Lowering a vehicle

To lower a vehicle off the Lift, follow this procedure:

1. Check under and around the vehicle to make sure the area is clear of all obstructions.

If any obstructions are found, **move them out of the way**.

2. Press and hold the **Up** Button for a second or two to move the Lift off its Safety Locks.

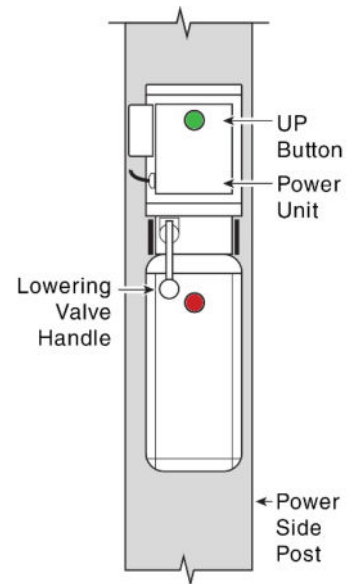

3. One at a time, pull down on each Safety Release Cable (one on each side of the Lift) as shown below.

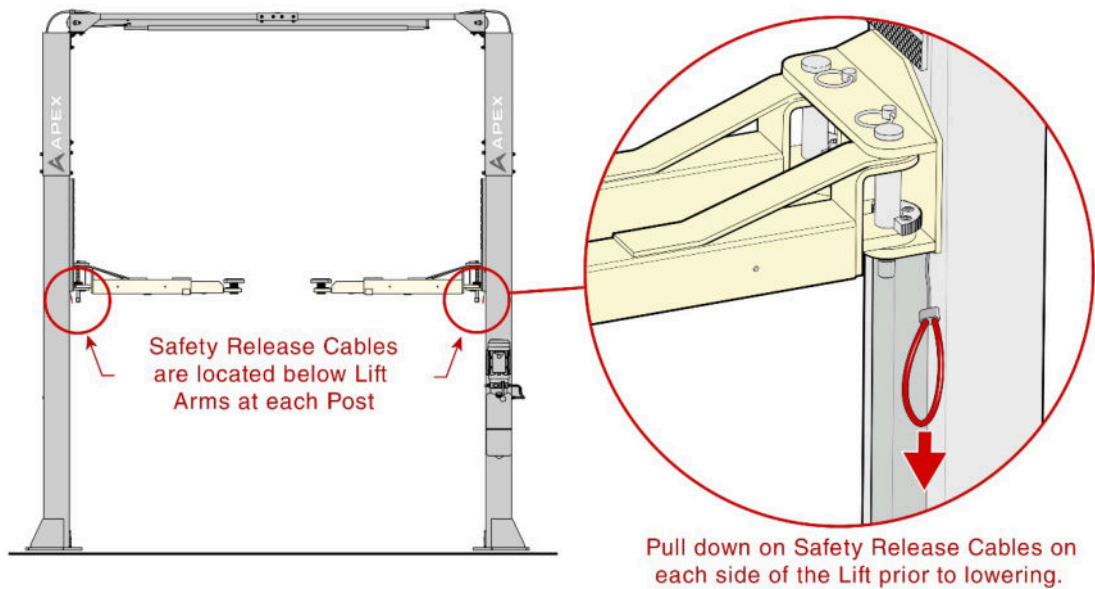

4. Press down and hold the Lowering Valve Handle. The Lift will begin lowering.

⚠ DANGER Do not override the Lift controls. For safety purposes, Lift controls are designed to stop the Lift if released. Overriding the Lift controls could lead to damage to the Lift or the vehicle on the Lift, injury, or in rare cases, death to persons near the Lift.

⚠ CAUTION Remain clear of the Lift as it descends and obey the pinch point warning decals.

5. When the Lift is on the ground, release the Lowering Valve Handle, then move all four Lift Arms to their full drive-through positions, to allow an unobstructed exit for the vehicle.
6. Carefully drive the vehicle out.

About Safety Locks

A Safety Lock **position** is defined as when the Lift is engaged on both Safety Locks (one on each Post) at the same height. Having multiple Safety Lock positions allows the Lift to be locked at the ideal height for any given vehicle and service condition.

⚠ CAUTION Verify that both Safety Locks are engaged at the same height on both Posts. Having the Lift engaged on Safety Locks at two different heights, or a Safety Lock on one Post engaged but the one on the other Post not engaged creates a dangerous situation.

Safety Lock positions are created by the Safety Lock Weldments, which are on the inside of each Post. As the Lift rises the spring-loaded Safety Locks hit the Safety Lock Weldments, creating a “thumping” sound. The Safety Locks are fully engaged when they are securely lowered onto a Safety Lock Weldment, as shown in the illustration below.

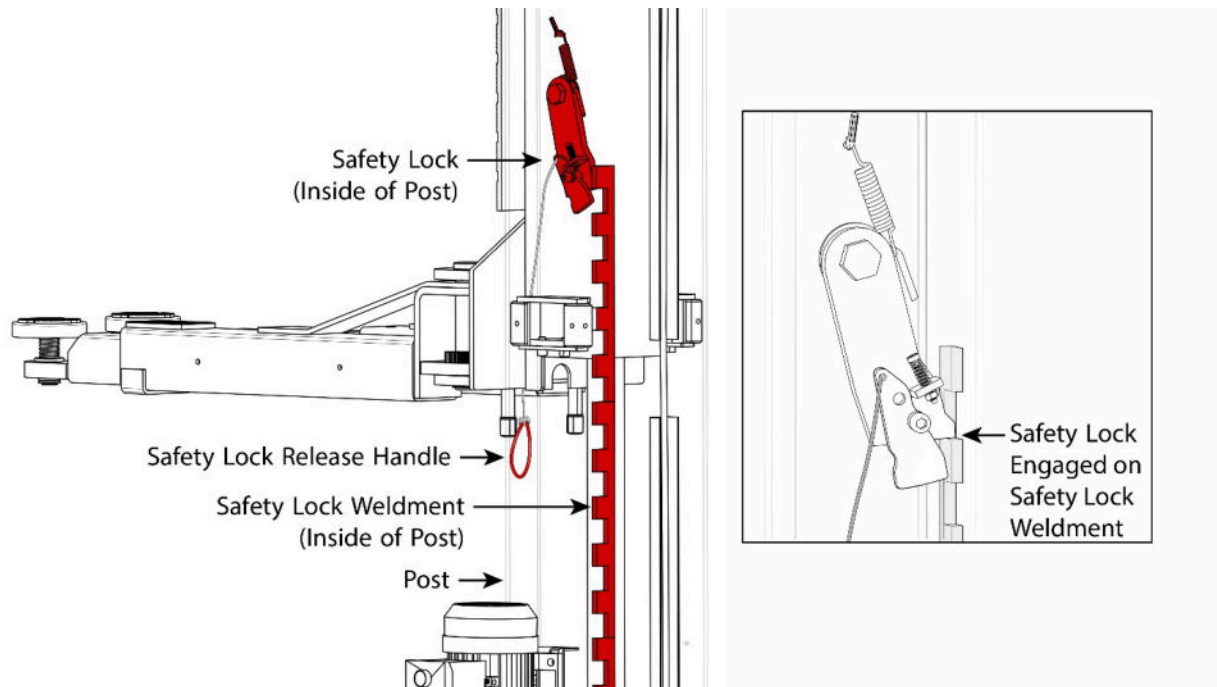





Illustrations not to scale. Some components removed for clarity.

To engage the Lift on its Safety Lock positions, press the **Up** Button and wait until the vehicle reaches the desired height for the work to be done, then listen for the “thump” as the Weldments pass the next Safety Lock position. When the “thump” is heard, release the **Up** Button and hold down the Lowering Valve Handle (on the front of the Power Unit) for a second or two to back the Lift down onto the just-passed Safety Locks. Release the Safety Lock Handle.

⚠ DANGER Only leave the Lift when it is either fully lowered or engaged on Safety Locks. ***If the Lift is left raised but not engaged on its Safety Locks, the vehicle is not secure.*** As a result, the vehicle could fall, possibly damaging the vehicle, the Lift, and injuring anyone under the vehicle.

Maintenance

-  **DANGER** Before performing any maintenance on the Lift, verify that it is completely disconnected from power. The Lift uses electrical energy. If the shop or organization has Lockout/Tagout policies, make sure to implement them before performing any maintenance. Anyone coming into contact with high voltage could be injured or killed.
-  **DANGER** Do not use the Lift if the cables are damaged or extremely worn. If the Lift is being raised and damage or extreme wear is noticed, very carefully lower it back to the ground. When the Lift is on the ground, remove it from service, disconnect it from power, and make necessary arrangements for repair.
-  **DANGER** Always wear proper Personal Protective Equipment (PPE) when working with hydraulics. Gloves and Safety Glasses are a minimum requirement. Keep away from suspected leaks. Use a clean piece of sheet metal to pass along hoses and fittings to detect leaks. Shut down the equipment if a leak is suspected.
-  **WARNING** Do not operate the Lift if maintenance issues are found. Instead, remove it from service and correct the maintenance issues. Technical support and service is available from the dealer, on the Web at bendpak.com/support, by email at support@bendpak.com, or by phone at **(888) 856-5820**. Online chat is also available at www.bendpak.com click the chat icon. 

Read the *Installation and Operation Manual* and understand how this equipment operates before using, maintaining, or repairing the Lift. Routine maintenance and adjustments are the responsibility of the owner/user and are not covered under warranty.

Routine maintenance and adjustments should be carried out on a regular basis as outlined below. Unless stated otherwise, all maintenance may be performed by the owner/employer and does not require trained lift service personnel. Replace worn, damaged or broken parts with original BendPak or BendPak approved parts or with parts that meet or exceed the original specifications.

Maintenance and Interval Recommendations:

The service life of this Lift is dependent on the level and frequency of care and maintenance provided. By simply following a few guidelines, the life of the Lift can be extended by many years. The following care and maintenance procedures not only help to ensure a long service life, they also aid in safe operation and the early detection of problems.

Tools required:

- Open end wrench set (SAE & Metric)
- Screwdrivers (Phillips and Slotted)
- Hydraulic fluid (same type and weight as the current fluid in use.)
- Clean shop towels
- Hex key set
- Lubricants
 - White lithium multi-purpose lubricant
 - Red lithium grease
 - ALMASOL Wire Rope Lubricant or 90W gear oil

Daily Maintenance

The following maintenance and interval recommendations are based on typical workday use and operation.

1. Keep the Lift and work area clean, to promote both safety and better problem visibility.
2. Visually inspect the Safety Locks and controls. Do not use the Lift if the Safety Locks or controls are damaged or excessively worn.
3. Check the hydraulic fluid Level in the Reservoir. Add fluid, if necessary.
4. Check for hydraulic fluid leaks on hoses, fittings, and cylinders. Hose covers that are cut, cracked, blistered, show signs of abrasion, kinking or flattened are to be replaced. Cylinder Ports that are cracked, show signs of leaking, or other damage should also be replaced.
5. Start the hydraulic system and raise the Lift Arms slightly to apply pressure. Pass a clean piece of sheet metal near the hydraulic hoses, fittings, and cylinders. Hydraulic fluid on the metal indicates a leak. Shut down and tagout the Lift to prevent use until all necessary repairs are made.

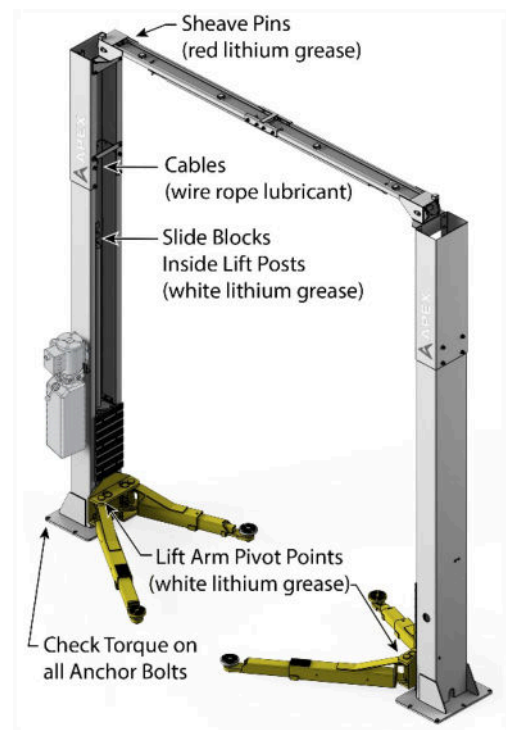

Monthly Maintenance

1. Remove, clean, and apply new red lithium grease to all Cable Sheave Pins as outlined in the Lubrication Procedure.
2. Inspect the condition of all Equalizing Cables and mechanisms. Run a shop towel over the cable surfaces while watching for snags. Replace cables as required.
3. Inspect all hydraulic hoses, fittings, and cylinders for damage and leaks.
4. Apply 90-WT gear oil or ALMASOL® Wire Rope Lubricant to both Equalizing Cables.
5. Apply white spray lithium grease to the four inside contact corners of both Posts.
6. Apply white spray lithium multi-purpose grease to all Lift Arm Pivot Points.
7. Inspect all Lift Arm Pins and locking mechanisms for damage and wear. Replace as required.
8. Verify all fasteners are torqued to specifications.
9. Verify all warning labels are in good condition and legible.

Every Two Months

Verify all Anchor Bolts are secure and torqued to 85-95 ft.-lbs.

Every three to five years or as required

1. Carefully check the Equalizing Cables for signs of damage or extreme wear. See *Wire Rope Inspection and Maintenance* for additional information.
2. Inspect and lubricate the Wire Rope, Sheaves and Pins.
If the Lift becomes inoperative in a raised position, refer to the **Troubleshooting** section.

Hydraulic System Maintenance

There is no scheduled replacement period on the hydraulic components in this system. All hydraulic system components are considered “On Condition” maintenance. Inspect periodically as outlined in the previous maintenance section and replace as required.

⚠ WARNING BendPak does not supply hydraulic fluid or lubricants with this Lift. **Always** refer to the Material Safety Data Sheet (MSDS) for safe handling and disposal information. MSDS are available from the fluid or lubricant supplier or manufacturer.

⚠ WARNING Hydraulic fluid contains toxic components and must be disposed of in accordance with all national, state, and local regulations. See **Disposing of Used Hydraulic Fluid**. Wear appropriate personal protective equipment for working with hydraulic fluid including gloves, and safety glasses.

NOTICE! BendPak does not authorize field repair of the Power Units. Field adjustment of the Pressure Relief Valve (PRV) is also not permitted.

The hydraulic system on the AL10C Lift should be inspected as required, but at a minimum once a year. Be advised there are no drains or test points in the hydraulic system.

Maintenance Steps:

1. Inspect the Cylinder Rod.
2. Hydraulic fluid Inspection for contamination and to verify the fluid level.
3. Inspect and clean the Hydraulic Fluid Filter.
4. Inspect the Hydraulic Hoses and/or lines for wear or damage.
5. Inspect the Reservoir and Reservoir Cap.

⚠ WARNING The power unit on the AL10C Lift is a hydraulic pump capable of developing pressures in excess of 3,000 psi (345 BAR). A pressure relief valve is used to set the pressure at the desired level. Tampering with, adjusting, modifying, or removing the relief valve is extremely dangerous and is not permitted.

⚠ WARNING All hydraulic components on the AL10C Lift should be assumed to be pressurized unless the Lift Arms have been lowered to the ground and the Lowering Valve Handle has been held in for at least ten seconds to de-pressurize the system.

Tools Required:

<ul style="list-style-type: none">• Clean shop towels• Oil absorbent material for cleaning spills.• Clean, clear glass container to examine the fluid sample.	<ul style="list-style-type: none">• Open end wrench set• Screwdrivers• Ladder• JIC fitting cap/plug	<ul style="list-style-type: none">• Funnel• Clean tube to draw a fluid sample.• Waste fluid containers
---	--	--

Hydraulic System Maintenance

1. Review this entire *Installation and Operation Manual* before attempting this procedure.
2. Read and understand all Danger, Warning, and Caution labels on the Lift. If any labels are illegible, contact BendPak to arrange for replacement labels to be sent.
3. Walk around the Lift and examine it carefully for damaged or worn mechanical components. If such components are found, have the damaged or defective components replaced or repaired.
4. Look for hydraulic fluid on the ground or on the Lift, which could indicate a leak in the hydraulic system.
5. Verify all hydraulic connections are tight.
6. Check the hydraulic fluid level in the Power Unit Reservoir.
7. Remove the Cover on each Lift Head to enable a view of the Cylinder and Equalizing Cables.
8. Verify all Lift Arms are on the ground. Hold the Lowering Valve Handle down for ten seconds to verify there is no pressure in the system.
9. Verify the area around the Lift is clear and no personnel are in danger.
10. Move the Power Disconnect switch to the **On** position.
11. Verify power is supplied to the Lift by briefly pressing the **Up** button. The Power Unit should start.
12. Raise the Lift Arms to the top Safety Lock position with no load on the Lift.

Inspecting the Cylinder Rods

1. A ladder may be required to access the top of the Lift Head. Visually inspect the Cylinder Rod for wear, corrosion, and pitting. These conditions may lead to leaking seals and moisture intrusion into the hydraulic fluid. If any of these conditions are found, the cylinder may need to be replaced.

Contact BendPak Support at bendpak.com/support, via email at support@bendpak.com, or by phone at **(888) 856-5820**.

2. If the Cylinder Rod is in good condition, replace the Cover and repeat the procedure on the other Lift Cylinder.
3. Lower the Lift Arms until they rest on the ground.
4. Hold the Lowering Valve Handle for an additional 10 seconds to ensure the hydraulic system is depressurized.
5. Turn the Lift's Power Disconnect switch to the **Off** position. Lockout/Tag Out the power disconnect to prevent unintentional start up during the maintenance procedure.

Inspecting the Hydraulic Fluid for Fill Level and Contamination

1. Remove the Reservoir Cap and draw a small sample of hydraulic fluid. This can be done by using a small, clean tube to reach down into the Reservoir. Once inserted into the fluid, cover the top end of the tube with a finger to hold the sample. Place the sample into a clean, clear glass container.
2. Visually examine the hydraulic fluid sample.
 - a. Clean hydraulic fluid ranges from almost clear to an amber color.

-
- b. When the hydraulic fluid becomes dark the system should be drained and replaced with new fluid.
 - c. If solids are visible in the fluid or found at the bottom of the Reservoir, the hydraulic fluid should be drained and replaced with new fluid.
 - d. Fluid with a milk-like tint indicates water in the hydraulic system. Remove all hydraulic fluid from the system and replace it with new fluid.
 - e. A change in the smell of hydraulic fluid may indicate contamination. Excessive air trapped in the fluid may create nitrogen compounds, which can emit a turpentine-like odor. If a distinct change in the odor of the fluid is noted, remove all fluid from the system and replace it with clean hydraulic fluid.
3. Check the fill level by visually comparing the fluid level with the markings on the exterior of the Reservoir.

Inspecting the Hoses/Lines and Fittings

1. Inspect all hydraulic hoses for swelling, pinching, kinking, fraying, bubbling, or other abrasions. Damaged or worn hoses should always be replaced before they fail in service.
2. Inspect hydraulic fittings to verify they are tight and undamaged. Tighten or replace as necessary.

Inspecting the Fluid Reservoir and Cap

1. Reservoir caps should be kept clean to prevent the migration of debris into the hydraulic system.
2. Inspect the Reservoir and Cap for cracks. If the Cap contains a filter, ensure that it is clean. Rinse in clean fluid, if necessary.
3. If the Reservoir, its Cap, or Seal are damaged, contact BendPak for replacement parts.

Draining The Hydraulic System

Draining the hydraulic system and replacing the fluid should only be undertaken if the fluid is contaminated. There are no drain valves, test points or strainers with magnets on the Lift's hydraulic system.

Gather shop towels and oil absorbent material in case of fluid spills. BendPak advises that an assistant be available to aid in keeping fluid spills to a minimum.

1. Retrieve a container capable of storing the 3.6 gal. (13.6 L) of hydraulic fluid from the system.
2. With the Lift Arms resting on the ground and the power disconnect in the **Off** position, hold down the Lower Lever (valve) for about 10 seconds to fully depressurize the entire system.
3. Open the system at the hydraulic hose routed from the Power Unit to the connection on the Power Side Post. Quickly cover the fitting with plastic wrap to keep contaminants out. Use shop towels to minimize any spilled hydraulic fluid.
4. Place the end of the hydraulic hose just removed from the bulkhead fitting tee into the waste fluid container.
5. Press the **Up** button while holding the hose in the container. Release the button when air begins to escape the hose.

-
6. Place a small waste oil container near each cylinder. Open the Connector on the Off-side Cylinder and place that end of the hydraulic hose into the container. Cover the Off-side Cylinder connector with a rag to absorb any fluid continuing to leak from the Cylinder.
 7. Open the hose connection on the Power Side Cylinder and place the hose end into the waste container to capture the fluid exiting the hose.

Inspecting and Cleaning the Filter

1. An assistant is recommended for this inspection. Gather tools for removal and oil clean-up supplies in case of a spill.
2. Remove the Power Unit Reservoir. The Reservoir is awkward to handle. Have an assistant support the Reservoir while it is loosened.
3. Remove the 100 mesh filter at the bottom of the suction pipe.
4. Inspect the filter for debris. If excessive amounts of debris are found:
 - a. Thoroughly rinse the filter in clean hydraulic fluid to remove contaminants.
 - b. Dispose of the old hydraulic fluid in accordance with national, state, and local regulations.
5. When the screen is clean, replace the filter on the suction pipe.
6. Use clean hydraulic fluid and shop towels to clean the Reservoir.
7. Once the Reservoir is clean, install the Reservoir back onto the Power Unit.
8. Fill the Reservoir with clean hydraulic fluid.
9. Reconnect all hydraulic hoses and verify they are tight and undamaged.
10. Dispose of dirty shop towels and oil absorbent materials in accordance with all national and local regulations.

Lubrication Procedure

 **WARNING** BendPak does not supply lubrication products with this Lift. **Always** refer to the Material Safety Data Sheet (MSDS) for safe handling and disposal information. MSDS are available from the lubricant supplier or manufacturer.

 **WARNING** Some lubricants may contain toxic components and must be disposed of in accordance with all national, state, and local regulations. Wear appropriate personal protective equipment for working with lubricating products including gloves and safety glasses.

Lubricating the Overhead Equalizing Cable Sheaves:

1. Raise the Lift Heads so that they rest on the lowest Safety Locks.
2. Block the Lift heads with a 4 x 4 or equivalent, to ensure the Lift Heads cannot descend while lubricating the Lift.
3. Remove the Cover from the Lift Head, then loosen the Equalizing Cable Nut at the top of the Lift Head to relax the cable.
4. Lubricate the Overhead Sheaves at the top of both Posts.
 - a. Remove the C-clip securing the sheave pins.
 - b. Remove the pin from the sheaves.
 - c. Apply red lithium grease to the pin.
 - d. Reinstall the sheave pins through the sheave, then insert the C-clip.

Lubricating the Bottom Cable Sheaves:

1. Remove the C-clip.
2. Remove the sheave pin.
3. Lubricate the pin with red lithium grease.
4. Replace the pin in the sheave and secure it with the C-clip.
5. Tighten the Equalizing Cable adjustment in the Lift Head.

See **Leveling** to readjust the Lift Arms.
6. Replace the Lift Head Cover after leveling the Lift Arms.
7. Spray the inside of the Post with white lithium grease
8. Spray the safety sheaves with white lithium grease.

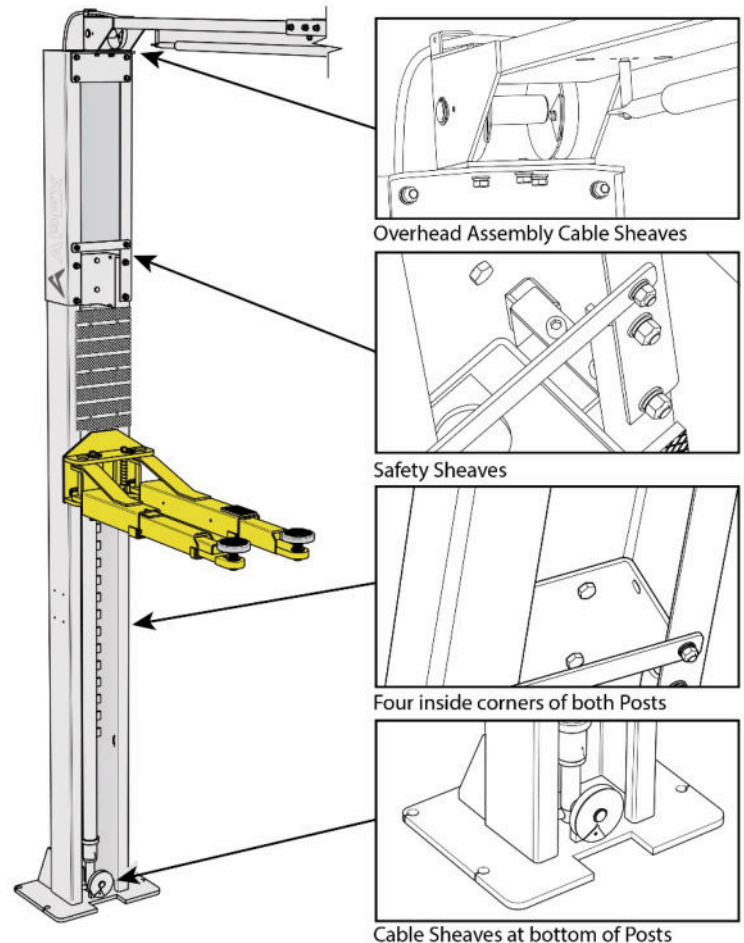

AL10C Wire Rope Inspection and Maintenance

The wire ropes on the AL10C Lift should be inspected regularly:

- Lifting cables should be replaced when there are visible signs of damage, stretching, or extreme wear. **Do not use the Lift if it has damaged or worn cables.**
- Lifting cables should always be maintained in a well-lubricated condition.

Wire rope is fully protected when each wire strand is lubricated both internally and externally. Excessive wear shortens the life of wire rope. Use a wire-rope lubricant that penetrates to the core of the rope and provides long-term lubrication between each individual strand, such as 90-WT gear oil or *ALMASOL® Wire Rope Lubricant*.

To make sure that the inner layers of the rope remain well lubricated, lubrication should be carried out at intervals not exceeding three months during operation.

- All sheaves and guide rollers in contact with the moving rope should be given regular visual checks for surface wear and lubricated to make sure they run freely. This should be carried out at appropriate intervals not to exceed three months during normal operation of the Lift.

For all sheave axles, use standard wheel bearing grease. For all sheaves and/or guide rollers, use 90-WT gear oil or a similar heavy lubricant, applied by any method including pump/spray dispensing, brush, hand, or swabbing.

- How often should the lifting cables be inspected?

Lifting cables should be visually inspected at least once each day when in use, as suggested by *American Petroleum Institute's Recommended Practice 54 Guidelines*. Any lifting cables that meet the criteria for removal must be immediately replaced.

- When should lifting cables be replaced due to broken wires?

Lifting cables should be removed from service when six randomly distributed broken wires appear within any one lay length, or three broken wires in one strand within one lay length.

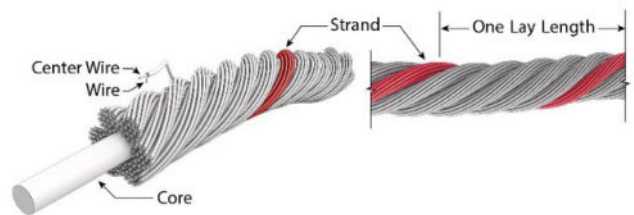

Steps to locate broken or damaged rope:



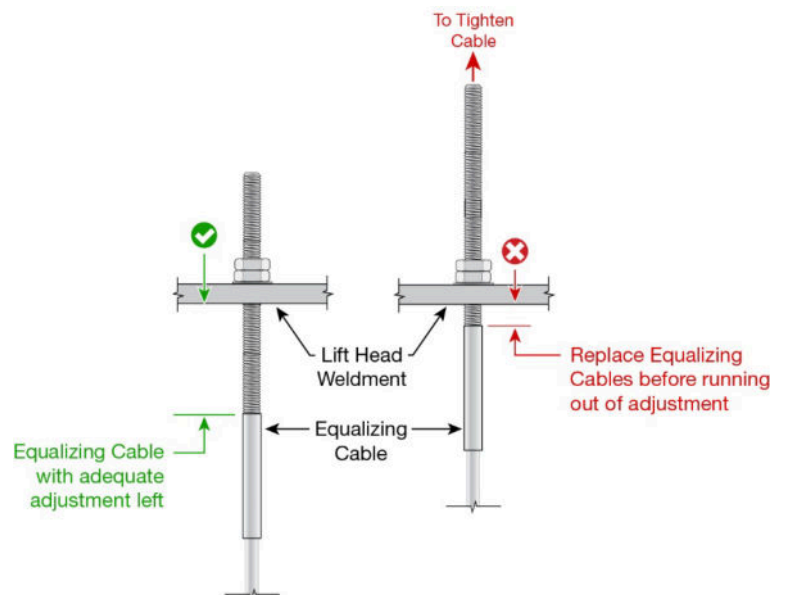

- Relax the rope to a stationary position and move the pick-up points off the sheaves. Clean the surface of the rope with a cloth or a wire brush, if necessary, so any breaks can be seen.
 - Flex the rope to expose any broken wires hidden in the valleys between the strands.
 - Visually check for any broken wires by running a cloth along the rope and checking for snags.
 - With an awl, probe between wires and strands and lift any wires that appear loose. Evidence of broken internal wires may require a more extensive rope examination.
- Are there other reasons to replace lifting cables?

- Yes. Corrosion that pits the wires and/or connectors, evidence of kinking, crushing, cutting, bird-caging, a popped core, wear that exceeds 10% of a wire's original diameter, or heat damage.
- Yes. Over-stretched cables require replacement. The Lift should be inspected daily, and the cables adjusted as needed to maintain level lifting. The cables should be replaced well before running out of adjustment at the Lift Head.

See page 38 for more information on leveling.

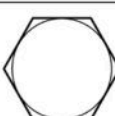

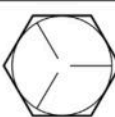
Torque Chart

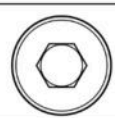
FASTENER TORQUE CHART													
Bolt Size (SAE)	Bolt Grade (SAE)	SAE Grade 0-1-2		SAE Grade 4.6		SAE Grade 5		SAE Grade 8		Socket Head Cap Screw SAE Grade			
												Bolt Class (Metric)	Metric Class 4.6
Bolt Size (SAE)	Bolt Size (Metric)	Tightening Torque			Tightening Torque			Tightening Torque					
		Lubricated (ft-lbs)	Zinc Plated (ft-lbs)	Plain & Dry (ft-lbs)	Lubricated (ft-lbs)	Zinc Plated (ft-lbs)	Plain & Dry (ft-lbs)	Lubricated (ft-lbs)	Zinc Plated (ft-lbs)	Plain & Dry (ft-lbs)			
1/4-20	M6 x1.0	2.3	2.6	3.0	5.8	6.6	7.7	8.3	9.4	11.1	9.7	11.0	13.0
5/16-18	M8 x 1.25	3.8	4.3	5.0	9.7	11.0	13.0	13.9	15.8	18.5	16.3	18.4	21.7
3/8-16	M10 x 1.50	10.8	12.3	14.4	27.9	31.6	37.2	39.9	45.2	53.2	46.7	52.9	62.2
7/16-14	N/A	24.0	27	30.0	35.0	42	50.0	55.0	59	70.0	61.0	68	76.0
1/2-13	M12 x 1.75	18.9	21.4	25.2	48.7	55.1	64.9	69.6	78.9	92.8	81.4	92.2	108.5
9/16-12	M14 x 2.00	30.2	34.2	40.2	77.8	88.1	103.7	111.3	126.1	148.4	130.0	147.4	173.4
5/8-11	M16 x 2.00	47	53	62	121	137	161	173	196	230	202	229	269
3/4-10	M18 x 2.50	65	73	86	167	189	222	239	270	318	279	316	372
7/8-9	M22 x 2.50	136	155	182	320	365	430	460	515	600	510	575	640

WARNING! Prior to installation, inspect all accompanying manuals, parts lists and catalogs to ensure you have all the necessary parts. Identify all fasteners and their proper torque settings as illustrated on this chart. Proper torquing practices cannot be over emphasized. Torque values are provided as a convenient method of achieving correct pre-loading of highly stressed fasteners. If the fasteners are not properly plated, the fastener threads are not clean and free of deformation, or are not properly lubricated, the correct fastener pre-load will not be achieved even though the given torque value is reached. For this reason, it is critical that all fasteners be inspected for proper plating, thread form and correctly lubricated prior to torquing. Failure to verify a fastener's serviceability or to correctly lubricate the fastener prior to assembly and torquing will result in the fastener not being properly pre-loaded and subsequent failure of the fastener may occur. The torque values can only be achieved if the nut (or tapped hole) has a proof load greater than or equal to the bolt's minimum ultimate tensile strength. Clamp loads estimated as 75% of proof load for specified bolts. Torque values are listed in foot-pounds. Torque wrenches should be calibrated on an annual basis. Never use an impact driver on a torque multiplier.

Troubleshooting

This section describes how to troubleshoot the AL10C Lift.

NOTICE If the Lift is not functioning correctly, it must be taken out of service until it is fixed.

Important: Replace worn, damaged or broken parts with original BendPak or BendPak approved parts, or with parts that meet or exceed the original manufacturer specifications.

⚠ DANGER Before performing maintenance on the Lift, confirm that it has been disconnected from its power source. The Lift uses electrical energy. If the shop or organization has Lockout/Tagout policies, implement them before performing any maintenance. Coming into contact with high voltage could result in sever injury or death.

Issue	Action to Take
Lift becomes inoperative in a raised position.	Verify there is sufficient hydraulic fluid in the Reservoir. Verify the Lift Carriages are above and clear of the Safety Locks. Verify none of the Hydraulic Hoses are pinched or leaking. Verify the Power Unit is being supplied power. Make sure the Lift is not overloaded. Make sure the load on the Lift is balanced. Contact bendpak.com/support . or by phone at (888) 856-5820 .
Lift Arms shake, move erratically or squeak when in use.	<ul style="list-style-type: none"> • Move the Lift Arms up and down a few times to flush any residual air from the Hydraulic System. • Bleed the Hydraulic Cylinders. Safely raise the Lift Heads 6 in. (152 mm), one at a time. Slightly open the Bleeder Valve at the top of the Cylinder and allow air to escape. Once Hydraulic Fluid begins to flow from the valve, close it securely and repeat this procedure on the opposite Hydraulic Cylinder.
Lift does not stay up.	Ensure that the Lift is securely engaged on its Safety Locks. Check for hydraulic fluid leaks.
Vehicle on Lift is not level.	Make sure the Lift is engaged on both Safety Locks at the same height. Make sure the Safety Locks in both Posts are fully engaged. If either condition is not met, carefully lower the vehicle back down to the ground and raise it again.
Motor not running.	Check connection to power source. Make sure it is plugged in and the appropriate voltage. Check the wiring diagram on the Power Unit for correct wiring.
Hydraulic fluid is dirty.	Replace the dirty hydraulic fluid with clean, approved ATF fluids, such as Dexron VI, Mercon V, Mercon LV, or comparable.
Lift makes odd noises.	<ul style="list-style-type: none"> • Perform the lubrication procedure. • Bleed each Hydraulic Cylinder. • Ensure that the Lift Arms are level.

Technical support and service is available from the dealer, on the Web at bendpak.com/support, by email at support@bendpak.com, or by phone at **(888) 856-5820**.

Online chat is also available at www.bendpak.com click the chat icon.



Disposing of Used Hydraulic Fluid

Used hydraulic fluid must never be disposed of by dropping it into the trash or dumping into the street. Hydraulic fluid has toxic ingredients that are harmful to the environment. Either recycle the hydraulic fluid or drop it off at a hazardous waste collection facility. Dirty or contaminated fluid must be treated as hazardous waste. Shop towels and/or granular absorbents that have soaked up hydraulic fluid should also be treated like hazardous waste and be disposed of at a hazardous waste collection facility.

To find an appropriate facility:

- Local automotive parts stores, auto care facilities, or automobile dealerships may accept fluid for recycling or, in some cases, for disposal. Contact them for more information.
- Cities, counties, and states often support both recycling facilities and hazardous waste collection facilities. Contact them to see if and where they have these programs.

If an appropriate facility cannot be found, the website earth911.com has resources that may be of help.

AL10C Lift Disposal - End of Service Life

Once the AL10C Lift has reached the end of its service life it must be disposed of properly. Metal recyclers will be able to advise on methods and costs to remove the Lift and reuse the materials, diverting them from landfills. The best option is to contact a metal recycling center and discuss the size and weight of the Lift to determine if the facility can deconstruct and recover the usable components and metals.

The hydraulic cylinders, hoses, fittings, and the power unit itself must be disposed of in accordance with current national, state, and local regulations governing the use and disposal of hazardous materials. These components and any used hydraulic fluid must not be disposed of by dropping it into the trash or dumping it into the street. The hydraulic fluid contains toxic ingredients that are harmful to the environment.

These components and the hydraulic fluid are required to be recycled or must be delivered to a hazardous waste collection facility.

For large amounts of hydraulic fluid, consider contacting a commercial waste disposal company. In all cases, the best approach is to find an appropriate facility and contact them—in advance—and ask them what kinds of fluids and materials they accept, what kind of containers they must be in, what hours they are open, their location, and any other information specific to their facility.

If an appropriate facility cannot be found, the website earth911.com has resources that may be of help.

Wiring Diagrams

DANGER

All wiring **must** be performed by a licensed electrician in accordance with all local and national electrical codes. Make sure that main electrical power has been disconnected from the Lift and cannot be re-energized until all procedures are complete. If the shop or organization has Lockout/ Tagout policies, make sure to implement them after connecting the Lift to power.

IMPORTANT!

The AL10C Power Unit consumes 23 Amps at 208-230 VAC, 60 Hz., single phase. The electrical circuit should be protected by a 25 Amp circuit breaker or time-delay fuse.

To Connect the Limit Switch:

Limit Switches may vary in appearance.

1. Remove and retain the Cover Screws.
2. Remove and retain the Switch Cover.
3. Fee the wire through the Strain Relief in the Switch Cover.
4. Strip the insulation off two of the conductors and connect to the **Normally Closed Terminals**.
5. Inspect to verify no stray wire strands are bridging across the terminals. If strands are bridging, correct before proceeding.
6. Replace the Switch Cover and secure with the screws removed in step 1.
7. Connect into the Power Unit electrical wiring to interrupt power when the Limit Switch is triggered. See **Power Unit Wiring**.

See the wiring diagram on the following page.

AL10C Power Unit
5585144
208-230VAC,
60Hz., 1 Ph., 23Amps

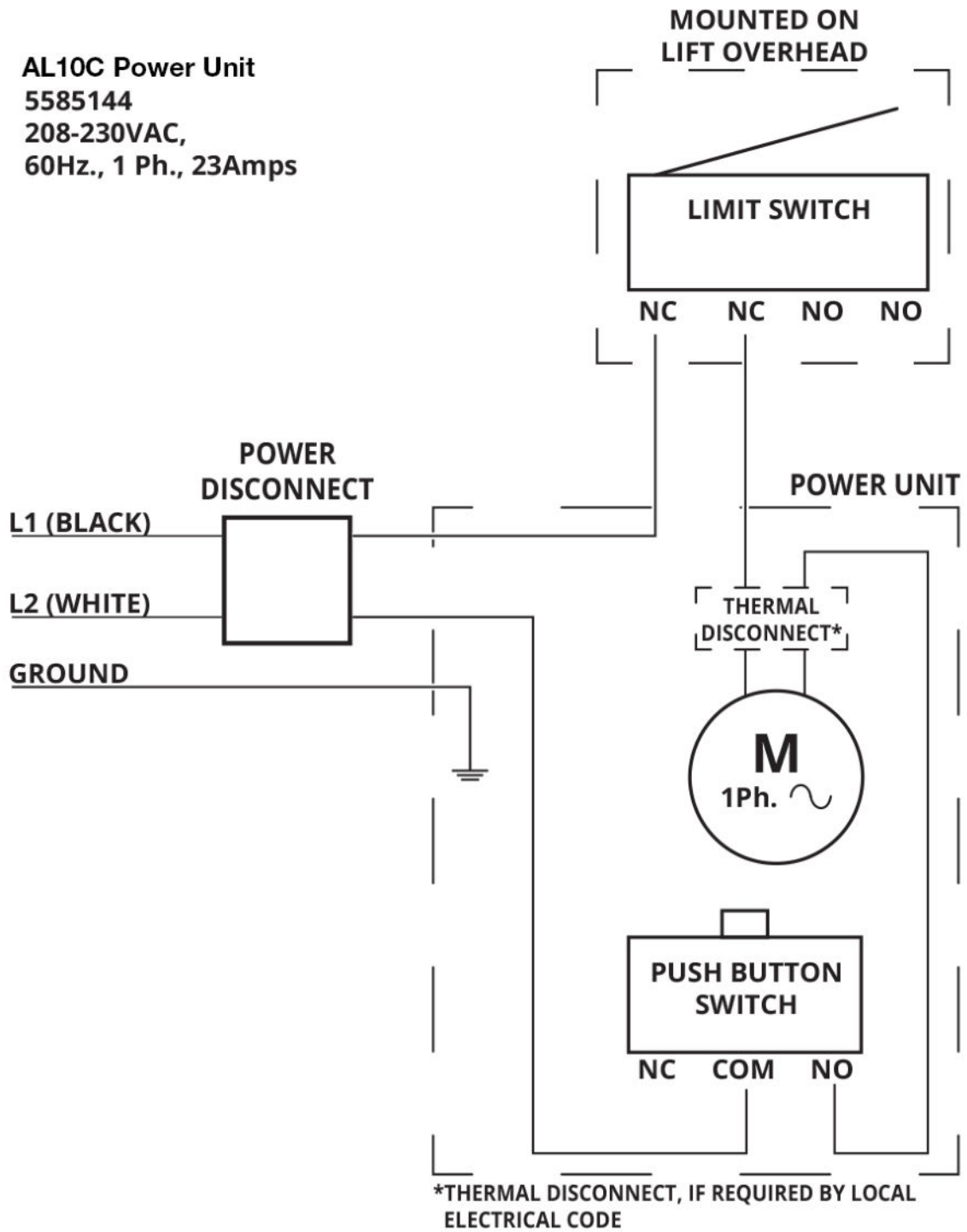

Labels



B

BendPak 30449 Agoura Road Agoura Hills, CA 91301 www.BendPak.com

LIFT TYPE: Surface Mount **MANUFACTURER:** BendPak. See data plate for product details
POWER: Electric-Hydraulic **INSTALLATION:** See manual or contact factory

Safety Instructions: If attachments, accessories, or configuration-modifying components that are located in the load path affect operation of the lift, affect the lift electrical listing, or affect intended vehicle accommodation are used on this lift and, if they are not certified for use on this lift, then the certification of this lift shall become null and void. Contact the participant for information pertaining to certified attachments, accessories, or configuration-modifying components.

BendPak lifts are supplied with concrete fasteners meeting the criteria as prescribed by ASTM E488/E488M-16. Lift buyers are responsible for any special regional, structural, and/or seismic anchoring requirements specified by any other agencies and/or codes such as the Uniform Building Code (UBC) and/or International Building Code (IBC).

The manufacturer, use, sale, or import of this product may be subject to one or more United States patents, or pending applications, owned by BendPak Inc.

Do Not Remove Engineered by BendPak Inc., USA PN 5905940 Made in China

PN 5905940

C

ATTENTION

MAXIMUM LIFTING CAPACITY
CAPACITÉ DE LEVAGE MAXIMALE

10000 Lbs.
4536 Kg.

PN 5905665

PN 5905655

E

WARNING
USE PROPER ADAPTERS
 Do not use any adapter that is not listed in this manual. The use of any other adapter may void the lift's certification and void the manufacturer's warranty.

ATTENTION
UTILISEZ DES ADAPTATEURS APPROPRIÉS
 Ne pas utiliser d'adaptateur qui n'est pas listé dans ce manuel. L'utilisation d'un autre adaptateur peut annuler la certification de la levatrice et annuler la garantie du fabricant.

FRAMER CHARGE ADAPTERS (Use of a frame charge adapter is limited to the maximum rated capacity of the adapter. Do not use any other adapter.)

USE A NEW ADAPTER (Do not use an old adapter. The use of an old adapter may void the lift's certification and void the manufacturer's warranty.)

REQUIREMENTS FOR NEW ADAPTERS: (Do not use any adapter that is not listed in this manual. The use of any other adapter may void the lift's certification and void the manufacturer's warranty.)

TO PLACE ORDER Monday - Friday
 1-800-828-8888 9am - 5pm PST
POUR COMMANDER Lundi - Vendredi
 1-800-828-8888 9h - 17h PST

PN 5906119

D

IMPORTANT
OPERATION / MAINTENANCE
INSTRUCTIONS - PLEASE READ
DANGER

DANGER
 NEVER allow contact with any moving parts on any equipment. Do not touch or lean against any moving parts. Do not touch or lean against any moving parts. Do not touch or lean against any moving parts.

DANGER
 Long wheelbase vehicles can damage lift and cause personal harm or injury to operator if loaded incorrectly. All vehicles MUST be positioned on lift with CHASSIS CENTERED between supports.

CAUTION
 NEVER lift any vehicle in any manner with lift. Do not lift any vehicle in any manner with lift. Do not lift any vehicle in any manner with lift.

WARNING
REGULAR INSPECTION AND MAINTENANCE
 Operator should be instructed if extensive wear or damage is evident, such as excessive brake stands, brake deterioration, or wear of heavy chains.

LIFT OPERATION
TO RAISE LIFT
 Read operating manual and safety instructions before use.
 Check overhead safety limit switch for proper function before starting lift.
 Verify all air connections are tight and engaged before any attempt to make lift work on any vehicle.
 Verify lift vehicle using manufacturer's recommended tire grade.
 Position vehicle between columns. Adjust spring arms so that vehicle is positioned with the center of gravity midway between column pads.
 Push in control panel of manufacturer's recommended tire grade.
 Use proper technique to raise lift.
 Do not lift any vehicle with lift. Do not lift any vehicle with lift. Do not lift any vehicle with lift.

TO LOWER LIFT
 Do not touch any moving parts on any equipment. Do not touch or lean against any moving parts. Do not touch or lean against any moving parts.

REQUIRED BIENNIAL MAINTENANCE
 A lift operator should be instructed if extensive wear or damage is evident, such as excessive brake stands, brake deterioration, or wear of heavy chains.

WARNING!
 NEVER allow contact with any moving parts on any equipment. Do not touch or lean against any moving parts. Do not touch or lean against any moving parts.

PN 5906167

F

⚠ DANGER

THE MAXIMUM LIFTING CAPACITY FOR THIS LIFT IS DESCRIBED BELOW

Maximum Lifting Capacity 10,000 lbs. / 4,536 kg
Max. Lifting Cap. / Front of Lift Center 5,000 lbs. / 2,268 kg
Max. Lifting Cap. / Rear of Lift Center 5,000 lbs. / 2,268 kg

Exceeding the weight capacity of this lift can damage lift and/or properly and may cause personal harm, injury or death to operators and/or bystanders. All vehicles MUST be positioned on lift with CENTER OF GRAVITY midway between adapters and/or centered on runways. Damage to lift due to overloading or misuse IS NOT covered under warranty.

LA CAPACITÉ DE LEVAGE MAXIMUM POUR CE LEVAGE EST DÉCRIT CI-DESSOUS

Capacité de Levage Maximale 10,000 lbs. / 4,536 kg
Max. Capacité De Levage. / Avant de centre de retèvement 5,000 lbs. / 2,268 kg
Max. Capacité De Levage. / Arrière du centre de levage 5,000 lbs. / 2,268 kg

Le dépassement de la capacité de poids de cet élévateur peut endommager l'ascenseur et / ou les biens et peut causer des dommages corporels, des blessures voire la mort aux opérateurs et / ou aux passants. Tous les véhicules DOIVENT être placés sur l'élévateur avec le CENTRE DE GRAVITÉ à mi-chemin entre les adaptateurs et / ou au centre des plateformes. Les dommages à soulever dus à la surcharge ou une mauvaise utilisation N'EST PAS couverte par la garantie.

PN 5905403

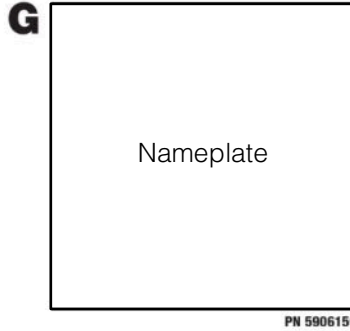

PN 5906156

H

NOTICE

Read operating and safety manuals before using lift.

NOTICE

Proper maintenance and inspection is necessary for safe operation.

NOTICE

Do not operate a damaged lift.

⚠ CAUTION	⚠ CAUTION
Lift to be used by trained operator only.	Authorized personnel only in lift area.
⚠ CAUTION	⚠ CAUTION
Use vehicle manufacturer's lift points.	Always use safety stands when removing or installing heavy components.
⚠ CAUTION	⚠ CAUTION
Use height extenders when necessary to ensure good contact.	Auxiliary adapters may reduce load capacity.

The messages and pictographs shown are generic in nature and are meant to generally represent typical common use of automotive lifts regardless of specific style.

Funding for the development and validation of these labels was provided by the Automotive Lift Institute, PO Box 3018 Indianton, IN, 46033.

They are protected by copyright. Set of labels may be obtained from ALI or its member companies. © 2009 by ALI, Inc. ALI0000000

⚠ WARNING	⚠ WARNING
Clear area if vehicle is in danger of falling.	Position vehicle with center of gravity midway between adapters.
⚠ WARNING	⚠ WARNING
Remain clear of lift when raising or lowering vehicle.	Avoid excessive rocking of vehicle while on lift.
⚠ WARNING	⚠ WARNING
Do not override self-closing lift controls.	Keep feet clear of lift while lowering.

The messages and pictographs shown are generic in nature and are meant to generally represent typical common use of automotive lifts regardless of specific style.

Funding for the development and validation of these labels was provided by the Automotive Lift Institute, PO Box 3018 Indianton, IN, 46033.

They are protected by copyright. Set of labels may be obtained from ALI or its member companies. © 2009 by ALI, Inc. ALI0000000

ALI Blue

PN 5905109
(Kit includes Blue, Yellow & Orange Labels)
(Order Labels from ALI)

ALI Yellow

ALI Orange



J

CALIFORNIA PROPOSITION 65

⚠ WARNING ⚠

WARNING! This product can expose you to chemicals including styrene and vinyl chloride which are on the list of over 500 chemicals identified by the State of California to cause cancer, birth defects or reproductive harm. ALWAYS use this product in accordance with the manufacturer's instructions. For more information, go to www.p65warnings.ca.gov. PN 5905775

PN 5905775

AL10C Product Label Positioning

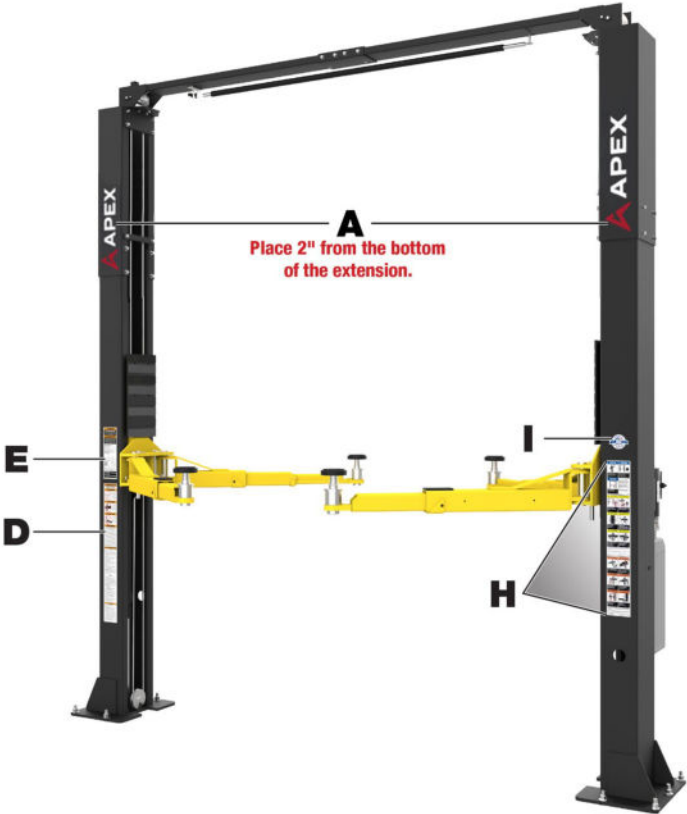
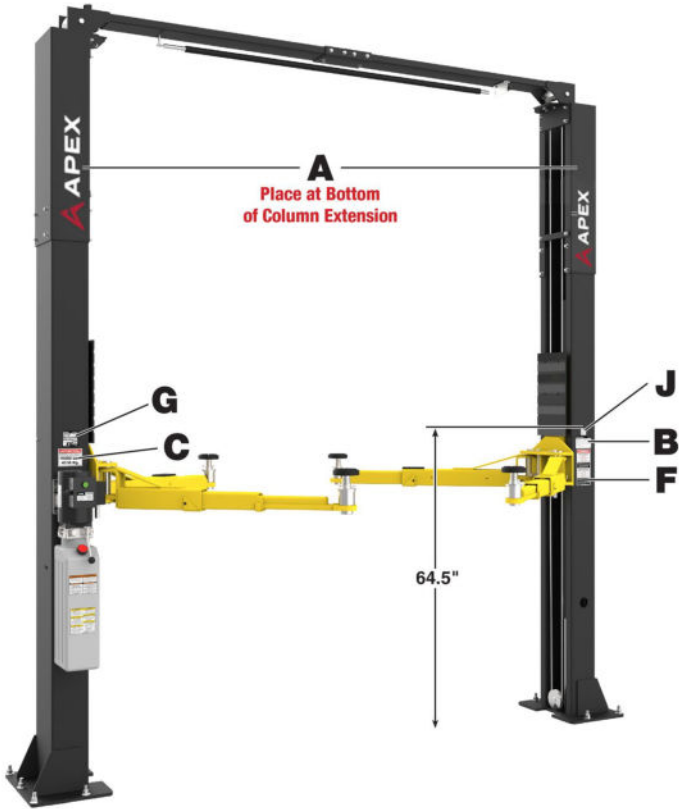

#	Part Number	Description	Qty	
1	5585144 5585147	- Power Unit; CLC-3-1-2700-M / 220V, 60HZ, 1PH, 2700 PSI PRV -Power Unit; CLC-3-3-2700-M / 220V, 50HZ, 3PH, 2700 PSI PRV	1	
2	5502067	Cylinder Assembly Ø2.0 x 69 in.	2	
3	5595858	Equalizer Cable Assembly Ø10 x 10020 mm DT	2	
4	5602121	Power Side Post Weldment	1	
5	5216334	Overhead Assembly	1	
6	5530152	HHB M12 x 1.75 x 30 FT, CL 10.9 Bolt	16	
7	5545347	Flat Washer M12 x Ø24, CL 10.9	32	
8	5545201	Split Lock Washer M12 x Ø21, CL 10.9	16	
9	5535998	Hex Nut M10 x 1.5, Class 10.9	16	
		Hex Nut M10 x 30 Bolt	22	
		M10 Flat Washer	44	
		Hex Nut M10	22	
		Hex Nut M10 x 15 mm Bolt	6	
10	5737433	Tie Plate	2	

#	Part Number	Description	Qty	
11	5570317	Hydraulic Hose Assembly Ø10 x 4180 mm, Double Straight (DS)	1	
12	5570318	Hydraulic Hose Assembly Ø10 x 5252 mm with Banjo Fitting	1	
13	5570321	Hydraulic Hose Assembly Ø10 x 1012 mm with Banjo Fitting	1	
14	5602122	Post Extension Weldment	2	
15	5602123	Offside Post Weldment	1	
16	5216335	Triple Telescoping Arm Assembly	2	
17	5216339	Lift Head Assembly	2	
18	5216333	Telescoping Screw Pad Assembly / 50 mm Pin / Each	4	
19	5210537	2-Post Telescoping Screw Pad Assembly / 50mm Pin / Includes Polyurethane Tuf-Pad / Set of 4	1	
20	5216336	Long Arm Assembly	2	
21	5575084	Sheave Assembly, Ø115 mm	6	

#	Part Number	Description	Qty	
22	5746747	Medium Stack Adapter / 6 3mm / 50 mm Pin / Each	4	
23	5210536	2-Post Stacking Truck/ Van Adapter / 63 mm / 50 mm Pin / Set of 4	1	
24	5210535	2-Post Stacking Truck/Van Adapter / 125 mm / 50 mm Pin / Set of 4	1	
25	5210573	2-Post Frame Cradle Pad/50 mm Pin / Set of 4	1	
26	5910070	Paint, RAL-7021 Black/ Grey 20% (SPRAY CAN)		
27	5595859	Safety Cable Assembly Ø2.5 x 590 mm	2	
28	5550186	Straight Fitting M14 x 1.5 Male Metric x M16 x 1.5 Male Metric / Power Unit Fitting	1	
29	5550190	Straight Fitting M14 x 1.5 Male Metric x G1/4" Female x 58 mm Long / Cylinder Fitting	2	
30	5550191	Tee-Fitting M16 x 1.5 Male Metric x M16 x 1.5 Male Metric x M16 x 1.5 Male Metric	1	
31	5550189	Banjo Bolt, G1/4 in.	2	
32	5550192	Straight Fitting M16 x 1.5 Male Metric x M16 x 1.5 Male Metric	1	
33	5570319	Hydraulic Hose Assembly Ø10 x 350 mm Double Bend (DB)	1	
34	5210511	Replacement Polyurethane Two-Post Lift Pad / Slip Over / Set of 4	Accessory	

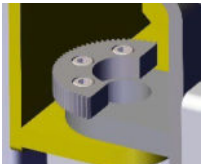
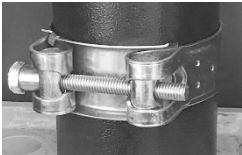
#	Part Number	Description	Qty	
35	5715070	Long Arm Bolt-On Rubber Pad / Each	Accessory	
36	5210512	Replacement Arm Topper Lift Pad / Fits Long Arms / Set of 2	Accessory	
37	5715059	Lift Head Bolt-On Rubber Pad	2	
38	5505683	Lift Head Pin Weldment / Ø40mm Diameter x 204 mm Length	4	
39	5737434	Bolt-On Arm Restraint Gear / 180-Degree	4	
40	5701242	Cylinder Clamp Assembly, Ø60 – 63 mm	2	
41	5520157	Limit Switch Assembly. AC 380V @ 0.8 Amp / DC 220V @ 0.16 Amp	1	
42	5520158	Micro Switch Wire Harness (4 meter)	1	
43	5530337	Anchor Bolt, ¾ in. x 6.3 in.	10	
44	5900593	Installation and Operation Manual	1	

Automotive Lift Institute (ALI) Store

See **ALI's Directory of Certified Lifts** (www.autolift.org/ali-directory-of-certified-lifts/) before making any lift purchase.

The **ALI Store** (www.autolift.org/ali-store/), a trusted source for workplace safety, offers a wide variety of professional, easy-to-use, and reasonably priced training and safety materials that will make any garage or shop a safer place to work.



Lifting It Right Online Certificate Course. Make *sure* you and your people are lifting vehicles the right way.



ALI Lift Inspector Certification Program Registration. Become an ALI Certified Lift Inspector.

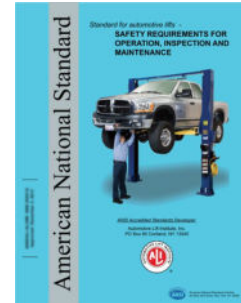

ANSI/ALI ALOIM Standard for Automotive Lifts. Safety Requirements for Operation, Inspection, and Maintenance.

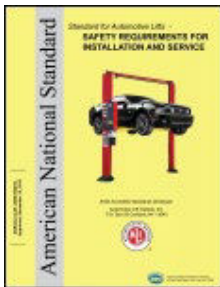

ANSI/ALI ALIS Standard. Safety Requirements for Installation and Service.

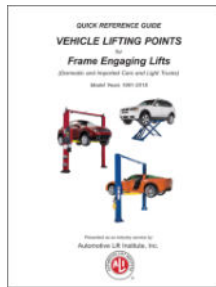

Guide to Hitting Vehicle Lifting Points for Frame-Engaging Lifts. Don't eyeball your lifting points, *know* where they are.



Lift Operator Safety Materials. Five safety documents in a single package.

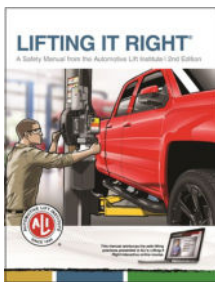

Lifting It Right. A hardcopy version of the *Lifting It Right* safety manual from the Automotive Lift Institute.



Uniform Warning Labels and Placards for 2-Posts. Labels in Mandarin, French Canadian, and Spanish are also available.



Safety Tips Card. Reminds your people of 13 key safety tips to follow daily.

Visit today and get the training and materials needed to work safely.
www.autolift.org/ali-store/.



30440 Agoura Rd.
Agoura Hills, CA 91301 USA
bendpak.com