

Mammut 66/33 Ton Jack

MODEL 91001

ESCO

PRO
SERIES

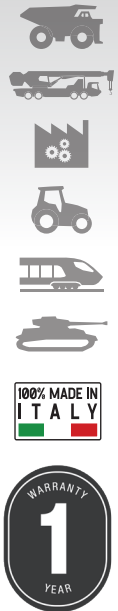

MAMMUT

FEATURES & BENEFITS

- Lightweight, compact and easy to handle/use design.
- Folding handle for easier transport and storage.
- Large wide pneumatic tires designed for use in extreme conditions.
- Special hook for transport and easy transport of jack.
- Available remote control for lifting and lowering jack from a safe distance away from the load - *Sold Separately*.
- Accessories available - *See back of flyer for details*.
- 100% manufactured in Italy
- One Year Warranty

HPM

HIGH - PERFORMANCE - MOTORPUMP

The new HPM motor pump, fitted on the M80/31, M80/42 and M100/40 jack, is the technological evolution of the previous version. Made of special materials to prevent corrosion and deformation even with intensive use and in adverse environments, it is free of any plastic parts to ensure long life and high performance.

With a performance improvement between 40% and 95% in terms of speed under load, and a frequency increased by 108%, it provides faster and more effective lifting even in the most severe conditions.

Designed and produced entirely in-house, it is the maximum technological evolution of our jacks.

SPECIFICATIONS

Model	91000
Style	M60-22
Capacity	66/33 ton 60/30 t
Net Weight	205 lb 93 kg
Working Air Pressure	145-174 psi 10-12 bar
Air Consumption	600 nl/min
Max. Height	17.6 in 448 mm
Min Height	8.7 in 222 mm
Number of Pistons	2
Stroke	8.8 in 226 mm
Application	Mine and oil field, Construction site, Industrial assembly, Agricultural, Railway applications, Military
Warranty	One Year Warranty
UPC	816904023577

Specifications & Accessories

MODEL 91001

The **MAMMUT RANGE OF JACKS** offers service professionals a solution that is safe and easy to use, for all those operations to lift earthmoving, construction, quarry, and mining machinery, where maintenance requires professional skills and expertise. All models are air/hydraulic operated and equipped with a dual descent valve for greater control when bearing weight and automatic piston return; they can also be fitted with a manual emergency pump (on request).

Specifications

MAMMUT

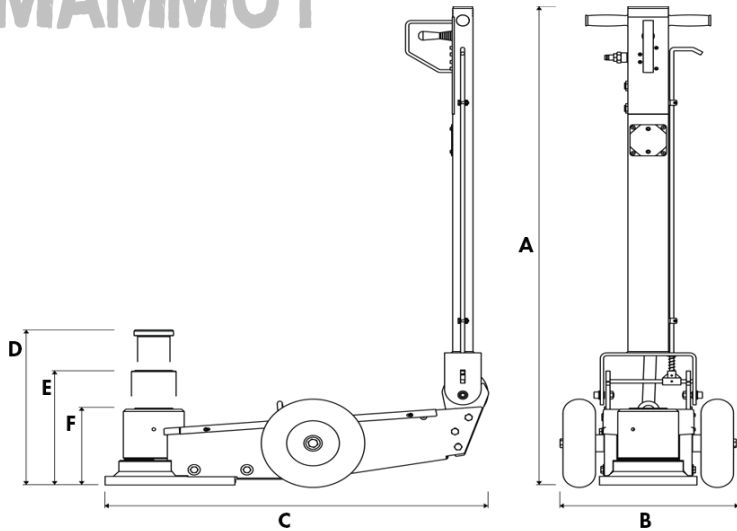

A	54.4 in 1382 mm
B	5.5 in 140 mm
C	37.2 in 945 mm
D	17.6 in 448 mm
E	13 in 331 mm
F	8.7 in 222mm

Accessories



Model	Description	Specs
91033	Extension Holder R	NA
91032	Extension Holder L	NA
91038	Extension	A: 3.125 in B: 1.5 in C: 0.75 in A: 80mm B: 35mm C: 20mm
91026	Extension	A: 6 in B: 1.5 in C: 0.75 in A: 150mm B: 35mm C: 20mm
91027	Extension	A: 9.875 in B: 1.5 in C: 0.75 in A: 250mm B: 35mm C: 20mm
91028	Extension	A: 11.875 in B: 1.5 in C: 0.75 in A: 300mm B: 35mm C: 20mm
91042	Tilting Plate	A: 1.875 in B: 1.5 in A: 46mm B: 35mm
91006	Remote Control	NA

NOTE: ESCO reserves the right to change, alter, or modify product(s) without notice. This includes but is not limited to product: color, design, parts, accessories, etc.

sales@esco.net **WWW.ESCO.NET** 1.800.352.9852



COPYRIGHT 2022 • 15270 Flight Path Drive • Brooksville, FL 34604

